

Midway City Council
16 August 2022
Regular Meeting

Ordinance 2022-21 /
Performing Arts Centers



CITY COUNCIL MEETING STAFF REPORT

DATE OF MEETING: August 16, 2022

NAME OF APPLICANT: Midway City

AGENDA ITEM: Code Text Amendment of Section 16.5.2, 16.13.10, and 12.11.020

ITEM: 10

Stuart Waldrip, representative for the Midway Arts Center Foundation, is proposing an amendment to section 16.5.2: Permitted and Conditional Uses (Commercial C-2 and C-3 Zones) to add indoor performing arts centers as a conditional use in the C-2 zone. He is also proposing an amendment to section 16.13.10: Maximum Height Provisions for all Buildings, and section 12.11.020: Exceptions, to include indoor performing arts centers in the list of structures that are allowed to exceed stated height requirements.

BACKGROUND:

Stuart Waldrip, representing the Midway Arts Center Foundation, is proposing two general amendments to the Midway municipal code. One amendment to title 16, would add indoor performing arts centers as a conditional use in the C-2 zone, the other amendments would adjust similar sections in 16.13.10 and 12.11.020 that provide exceptions to the maximum height requirements for specific types of buildings. These adjustments are being requested by the Midway Arts Center Foundation as they hope to propose an indoor performing arts center (not to exceed 50,000 sq. ft. per the proposed code text amendment) at approximately 330 East Main Street. The 1.6-acre site where they are proposing the facility is zoned C-2, which currently does not allow for the proposed use. It is important to note that the proposed amendment would allow performing arts centers in all of the C-2 zone, not only the aforementioned site of which, in this report, is included site specific information.

Additionally, the applicant is proposing to amend the code that would expand the height limit for architectural features of a performing arts center to increase from 52.5’ to a limit based on the setbacks for the structure. The C-2 zone has a 35’ height limit for all structures (excluding public buildings and churches) which is measured as the vertical distance from natural grade to the highest point of the roof. To allow for unusual conditions or appurtenances some exceptions are allowed. One such exception is for church spires, bell towers, finials, and like architectural features which are allowed to extend above the 35’ maximum height by up to 50 percent (52 feet 6 inches for a 35-foot building). The proposed performing arts center does include a clock tower which would allow for the increased height limit for the architectural feature. The proposed code text amendment would also allow a performing arts center an increased height limit measured from natural grade to the roof and to the height of any architectural features. Currently public buildings and churches may be erected to any height provided the building is set back from required building setback lines a distance of a least 1 foot for each additional foot of building height above the maximum height permitted. The applicant is proposing to include performing arts centers on the short list of structures with special maximum height restrictions but with one difference for performing arts centers. The difference is public buildings and churches have a height limit based on the setback, which would allow living space above a 35’ height. The proposed code amendment for performing arts centers would not allow living space above 35’ but only architectural features would be allowed to increase height based on the setback of the structure from the property line. This is different from the current restrictions for all structures except public buildings and churches that are limited to a height of 52.5’ for architectural elements.

Specifically, the proposed code amendments would appear as the following in the code (text in red would be added to the code):

1. USES IN THE C-2 AND C-3 ZONES

To be Added to Section 16.5.2 - Permitted and Conditional Uses:

USES	C-2	C-3
Indoor Performing Arts Centers (up to 50,000 sq. ft.) with largest audience venue up to 500 seats, primarily for live performances	C	N

2. SUPPLEMENTARY REQUIREMENTS IN ZONES

Section 16.13.10 Maximum Height Provisions for all Buildings

E. Public buildings, indoor performing arts centers (as to architectural features only), and churches may be erected to any height provided the building is set back from required building setback lines a distance of a least 1 foot for each additional foot of building height above the maximum height permitted.

3. BUILDING CODE PROVISIONS

Section 12.11.020 Exceptions

D. Public buildings, **indoor performing arts centers (as to architectural features only)**, and churches may be erected to any height provided the building is set back from required building setback lines a distance of at least 1 foot for each additional foot of building height above the maximum height permitted.

ANALYSIS:

Code text amendments fall under the category of a legislative action. Therefore, the City Council has broad discretion regarding the petition. It can be approved or denied based on the discretion of the City Council members. There is no obligation by the City to approve the proposals. If the City Council feels that the proposal will contribute to the community and will help promote the goals and policies of the General Plan, then the proposals should be considered. The City Council may consider any issue, included in the staff report or not, as a discussion item. Also, the City may require items from the petitioner that normally would not be allowed if a developer's property were properly located in a zone that allowed for the proposed use.

In reviewing the proposed code text amendment, staff reviews the Midway General Plan to see whether the proposed amendment helps accomplish its goals and policies. In 2016/2017, the current General Plan was revised and adopted. There does appear support in the General Plan for a performing arts center. Some support includes the following sections of the General Plan:

Community Vision Goals and Guidelines

Guideline 1: Provide recreational and cultural opportunities that would be of interest to the full range of age groups.

Guideline 4: Encourage all types of visual and performing arts.

Main Street

Main Street is the economic, architectural, and historical heart of the community. The most powerful and lasting image associated with Midway is Main Street. This commercial core should be developed as a distinctive shopping and business area emphasizing it as an attractive location for tourism tied to **Midway being a meeting place and staging area for festivals, special events, celebrations and a variety of community activities which will indeed produce a vibrant healthy community centerpiece.** Midway's Swiss theme and architectural design standards are prominent and important elements of Main Street.

Economic Goals and Guidelines

Guideline 3: Pursue arts, activities, recreation opportunities, and land uses that will create an experience to attract tourists.

Regarding the proposed amendment to the height restriction provisions that would allow a performing arts center to exceed the current height limitation of 35' for the roof and 52.5' for any allowed architectural elements, support from the General Plan is more difficult to identify. One possible section that would support the proposed amendment is found in the Main Street section of the General Plan which states the following:

Main Street Element page 61:

Design – Using proper design standards such as setbacks, storefronts size and placement will improve the overall appearance and walkability.

The proposed structure is larger than most structures that are currently located along Main Street and without an amendment to the height restriction, the design for a performing arts center without the added architectural element of a clock tower might not have a good proportional design.

The other side of the issue to consider is viewshed. If the structure is allowed a greater height than the current code allows there will be an impact to the surrounding neighboring properties and from Main Street for pedestrians and from vehicles. In this case, a better architectural design and proportions will lead to the loss of views from the surrounding area.

Elements of the Community Vision:

Effective planning through clustering, setbacks, Transfer Development Rights and animal/agriculture ordinances will help Midway to preserve its view corridors, maintain open spaces and reinforce a country/rural feeling.

Midway's historical preservation Master Plan will identify the specific structures the City would like to preserve/restore, the view corridors it would like to preserve and the elements of the pioneer heritage it would like to maintain.

As mentioned earlier, a code text amendment is a legislative action and therefore, the City Council has broad discretion. The City Council may consider all issues when considering the proposal. Other items the City Council may want to consider include traffic impact, parking, economic and tourism impact, visual impact, site feasibility, project feasibility, and long-term feasibility.

Economic and Tourism Impact – A performing arts center would be an economic generator that would draw in patrons and tourists which in turn would spend money in Midway at restaurants, shops, short-term lodging facilities, and gas stations. It seems likely that those businesses would benefit if a performing arts center were built. Midway would also receive the tax benefit from the increased activity.

Traffic Impact – Staff requested a traffic impact analysis (see attached) which was submitted with the application. Based on only one theater in the performing arts center being used at a time, the maximum number of patrons is 450 which would generate 180

trips. The model assumes 2.5 people per vehicle. Actors, stagehands, and staff would total approximately 50 people and would generate 50 trips. The total of all trips generated per event would be a maximum of 225 trips. The applicant has supplied some traffic studies that are attached to this report. One of the studies is for The Village development. This is a development located to the northeast of the proposed performing arts center site. It does give information about current traffic, but it is not specific to the proposed site, nor does it appear to contain a performing arts center in the study. The second study is specific to a performing arts center and does give information on the traffic impact of the proposed use. One of the main concerns with traffic is the constant impact traffic will have on Midway streets. While it is true that there have been many years of performances that have generated peak traffic counts on Midway streets, those performances have been limited to about 30 days a year. If a performing arts center is approved then, according to the applicants, there will be 200+ days of active use.

Parking – The current code includes a parking requirement for theaters which requires one parking space per four people based on the design. Based on a maximum of 500 people maximum per performance (450 patrons and 50 actors, stagehands, and staff) a total of 125 stalls would be required. The applicant has provided three different parking plans. The first is a shared parking plan with Millstream Properties which owns the parking lots to the east and to the south of the proposed performing arts center. This option does not have support from Millstream Properties based on the public comments made from a representative of Millstream Properties. The second is a plan where all the parking is contained on the performing arts center property. This plan could work if it has the proper access. Again, a representative of Millstream Properties stated that shared access has not been agreed to. If the performing arts property is not able to use Millstream Properties' access, then the performing arts center will need to find its own access. It may be possible to access on the west side of the performing arts center property, but UDOT will need to approve the proposed access. The third option to have some parking on the performing arts center property but to also have 60 stalls on the Olde Swiss Square property located to the west. Any off-site parking agreement will need to be approved by the City Council. The City Council may approve a combined parking agreement between two adjoining property owners if they find the proposed agreement is acceptable. Staff wants to emphasize that any agreement that is approved by the City Council should be in perpetuity. Staff's concern is that if the agreement expires, and is not renewed, then the performing arts center would be severely under parked. The parking needs to be a permanent solution. Option two would provide all the parking on-site but some of the parking would be located under the theater. When considering other land use applications that have proposed below grade parking, the City has had concerns that Midway's generally high-water table could be an issue with the below grade parking.

Visual Impact – A performing arts center would be a large building on Main Street. If the building is designed appropriately; it could be a flagship building that helps enhance the Swiss and old European architecture that is so important to Midway. A large building, especially with an increased maximum height, would also impact views from surrounding properties. The applicant has provided some drawings that help visually show the impact of a performing arts center on Main Street (please see attached). Staff has reviewed the

code height restrictions that would be allowed if the proposed amendment is approved, and the following is analysis of the required front setback and height for a performing arts center. The current height limitation is 35' for the roof and 52.5' for any allowed architectural elements. The proposed amendment would allow for a performing arts center to increase in height (only for architectural elements) if setbacks are increased on a ratio of 1:1. For example, if the tower on a performing arts center reached 70' then the required front setback would be 25.5', instead of the minimum 10' front setback. This is based on the maximum height of the structure being 35' (52.5' for architectural elements). With the increased height of 70', the building would need to be setback an additional 17.5' from the original 10' setback for a total of 27.5'. If the tower were 75' tall then the front setback would need to be 32.5' (any setback greater than 30' would require specific City Council approval).

Site Feasibility – Staff has asked the applicant for a geotechnical report specific to the proposed site of the performing arts center to help determine if the site is feasible for the proposed use and structure. A report has been submitted to staff and is currently being reviewed by Horrocks Engineers.

Project Feasibility – The applicant has submitted information regarding fundraising to gather the needed funds to purchase and develop the property. It is unknown how likely it will be to gather the roughly 45 million dollars required to complete the project. The City must consider the possibility that, if approved, the building might only be partially completed and the potential problems that would arise from such a scenario. Though unlikely, it is also important to consider the possibility of an abandoned large building on Main Street. The applicant has supplied more information on their proposed timeline (please see attached). There are many factors that can come into play regarding proposed timelines. The applicant has stated that construction will not begin until all the required funds are committed. This is helpful but there could still be flaws with this proposed scenario, especially if committed funds are never paid.

Long-Term Feasibility – The applicant has submitted some information on long-term feasibility that would include maintenance, management, etc. They plan to establish a four-million-dollar endowment fund that will provide approximately \$200,000 each year for facility upkeep and to lower rental costs for local arts groups.

PLANNING COMMISSION RECOMMENDATION:

Motion: Commissioner Bouwhuis: I make a motion that we recommend approval for an amendment to section 16.5.2: Permitted and Conditional Uses (Commercial C-2 and C-3 Zones) to add indoor performing arts centers as a conditional use in the C-2 zone. He is also proposing an amendment to section 16.13.10: Maximum Height Provisions for all Buildings, and section 12.11.020: Exceptions, to include indoor performing arts centers in the list of structures that are allowed to exceed stated height requirements. Accept the staff findings that are included in the staff report and adding two other findings, one being that the C-2 and the C-3 zones is consistent in the intent with this type of use. Also,

a new conditional use process needs to be in place to make considerations on impacts on the community such as parking and other concerns that have been brought up.

Seconded: Commissioner Cliften

Chairman Nicholas: Any discussion on the motion?

Chairman Nicholas: All in favor.

Ayes: Commissioners: Ream, Bouwhuis and Cliften

Nays: Garland and Simons

Motion: Passed

POSSIBLE FINDINGS:

- The proposed amendments, if approved, are not limited to the applicant's proposed site but would be a possibility for the entire C-2 zone
- The proposed amendments are a legislative action, and the City Council has broad discretion on whether to approve the amendments
- Promotes the goals and objectives of the General Plan which includes encouraging all types of visual and performing arts
- Could help generate economic activity for other Midway businesses and will help expand the tax base for Midway
- If the height limit is expanded for a performing arts center, views from surrounding properties will be impacted
- A traffic study has been submitted
- A geotechnical report has been submitted

ALTERNATIVE ACTIONS:

1. Approval. This action can be taken if the City Council finds that the proposed language is an acceptable amendment to the City's Municipal Code.
 - a. Accept staff report
 - b. List accepted findings

2. Continuance. This action can be taken if the City Council would like to continue exploring potential options for the amendment.
 - a. Accept staff report
 - b. List accepted findings
 - c. Reasons for continuance
 - i. Unresolved issues that must be addressed
 - d. Date when the item will be heard again

3. Denial. This action can be taken if the City Council finds that the proposed amendment is not an acceptable revision to the City's Municipal Code.
 - a. Accept staff report
 - b. List accepted findings
 - c. Reasons for denial

JULY 9TH, 2022

Mayor Celeste Johnson;

I am writing for myself as a Midway resident of Valais, as well as the President of the Wasatch County Arts Council. I would welcome the opportunity to present the progress we have made as the Community Arts Center of Heber Valley. But this is not the time.

I do, however, want to make a few comments regarding the Waldrip's proposed theatre on Main Street in Midway. In sitting through several planning commission meetings, I did realize some inequities in the process. During public comments, I was the first speaker. I not only made some comments that were positive regarding the Midway theatre and the crowd she had brought to the meeting. Following my comments, Stu Waldrip asked to make a rebuttal. I did not think that was permitted. He was granted more time than I was given and proceeded to tell untruths about our program.

I have to admit that I overreacted and raised my voice. The Planning Commission gave several points for the Waldrips to accomplish. One was to find a way to work with the CAC. We have approached the Waldrip's several times over the last few years to ask them to join the theatre group. One meeting was mediated by Mike Kohler. While mediation is a compromise, that never occurred. Following the planning commission meeting, I received a text from Ms. Waldrip as she thought the meeting was "contentious" and we could not work together. Case closed.

Never did I discuss the questionable setback, I did question the calculations of the number of parking spaces allotted. The concern is that the Waldrip's program becomes, not a community theatre, but a Sue Waldrip repertoire theatre. While it plays on the quality production she has produced, it eliminates other production houses from using by her choice.

I ask that you consider the Waldrip's magnificent planned contribution to Main Street with the open eyes you give to every project. The Waldrip's legacy would be forever a central part of Main Street. The Community Arts Center of the Heber Valley will reach the Valley and beyond and will welcome everyone.

Sincerely,
Pat Sweeney
President, Wasatch County Arts Council





MIDWAY

ARTS

CENTER

High Valley Arts-
Midway Arts Center

Code Text
Amendment
Application

July 19, 2022
Midway City Council

G|S

GRAYSTONE
STRATEGIES





IMPORTANT: Your application cannot be processed until determined complete by the Planning Staff. An application shall be considered complete when all applicable fees are paid (such as Midway Water Board, Midway Sanitation District, out-of-pocket expenses, etc.) and all items listed herewith are provided or considered not applicable by the Planning Office. All application fees are non-refundable.

Amendment to the Land Use Code Text:

Section 16.26.7 Amendments

The Midway City Land Use Title and accompanying zoning map may be amended as follows:

- A. The Planning Commission shall, after providing the proper notice requirements, hold a public hearing on a proposed amendment to the Land Use Title or zoning map. After holding the public hearing and receiving any public comment on the proposed amendment, the Planning Commission shall make a recommendation to the City Council on the proposed amendment.
- B. The City Council may amend any provision of the Land Use Title or the accompanying zoning map after the Planning Commission has held a public hearing and made a recommendation to the City Council on the proposed amendment; provided, however that the City Council shall, after providing the proper notice requirements also hold a public hearing on the proposed amendment before voting the amendment.

CHECKLIST:

- Completed application
- Written statement formally requesting the amendment and identifying why the proposed changes are necessary:
 - Specify the section to be amended and provide proposed language
 - Identify the positive impact of the proposed changes;
 - Identify the negative impact of the proposed changes;
 - State how the proposal is in the best interest of the community and the general public;
 - State how the proposed changes to the Land Use Code text promote the goals and objectives of the General Plan
- Other things as may be required by the Planning Department
- Payment of fees and costs

PROPOSED CODE LANGUAGE AMENDMENTS

Proposed changes in bold red text

1. USES IN THE C-2 AND C-3 ZONES

To be Added to Section 16.5.2 - Permitted and Conditional Uses:

USES	C-2	C-3
Indoor Performing Arts Centers (up to 50,000 sq. ft.) with largest audience venue up to 500 seats, primarily for live performances	C	N

2. SUPPLEMENTARY REQUIREMENTS IN ZONES

Section 16.13.10 Maximum Height Provisions for all Buildings

The height of any building shall not exceed 35 feet. The total height shall be measured as the vertical distance from the natural grade, as defined in this Title, to the highest point of a roof. To allow for unusual conditions or appurtenances the following exceptions apply:

A. Antennas, chimneys, flues, vents, or similar structures may extend up to 5 feet above the specified maximum height limit.

B. Water towers and mechanical equipment may extend up to 5 feet above the specified maximum height limit.

C. Church spires, bell towers, finials, and like architectural features as well as flag poles, may extend above the specified maximum height limit by up to 50 percent of the height limit (52 feet 6 inches for a 35-foot building), but shall not contain any habitable spaces above the maximum height.

D. The height of buildings in Resort Zones may exceed 35 feet if all the requirements of the Recreational Resort Chapter of this Title are satisfied.

E. Public buildings, **indoor performing arts centers (as to architectural features only)**, and churches may be erected to any height provided the building is set back from required building setback lines a distance of at least 1 foot for each additional foot of building height above the maximum height permitted.

F. Special height requirements for some buildings on benches and slopes greater than 10 percent are imposed by the Sensitive Lands Chapter of this Title. These restrictions on building height shall be applied where applicable.

3. BUILDING CODE PROVISIONS

Section 12.11.020 Exceptions

To allow for unusual conditions or appurtenances, the following exceptions shall apply:

A. Antennas, chimneys, flues, vents, or similar structures may extend up to five feet above the specified minimum height limit.

B. Water towers and mechanical equipment may extend up to five feet above the specified maximum height limit.

C. Church spires, bell towers, finials and turrets, as well as flag poles, may extend above the specified maximum height limit by up to 50 percent of the height limit, but shall not contain any habitable spaces above the maximum height.

D. Public buildings, **indoor performing arts centers (as to architectural features only)**, and churches may be erected to any height provided the building is set back from the required building setback lines a distance of at least one foot for each additional foot of building height above the maximum height permitted.

DETAILED STATEMENT AND REASONS

• History

The pioneers and their leaders greatly prized cultural and performing arts. From Lethe Tatge to Midway's Social Hall (now the Cannery), to the lovely classical architecture of the early buildings, the history of Midway is intertwined with cultural and performing arts.

"Theaters" were historically a conditional use in the commercial zones of Midway. Only very recently was that use inadvertently deleted in a failed restructuring of the commercial zones. The MAC cannot go forward as planned without restoring a concise, targeted conditional use for this type of indoor performing arts center, as proposed.

The Mayor, with concurrence from all 5 Council members, has recently written a letter of support for the general concept of a performing arts center in our city. It is attached for ease of reference.

• Reason 1 for the Changes - C-2 Zone Use

Midway's General Plan has always encouraged preservation of culture, history, and family-friendly activities, such as those that will be a part of the MAC.

General Plan, Community Vision, Goal 3:

"Guideline 1: Provide recreational and cultural opportunities that would be of interest to the full range of age groups."

"Guideline 4: Encourage all types of visual and performing arts."

The MAC, with its family-oriented and broad programs for youth and adults in the performing arts, together with displays of visual arts, will go a long way toward accomplishment of this goal.

General Plan, Main Street:

"[A]n attractive location for tourism tied to Midway being a meeting place and staging area for festivals, special events, celebrations and a variety of community activities which will indeed produce a vibrant healthy community centerpiece. Midway's Swiss theme and architectural design standards are prominent and important elements of Main Street."

"well suited for the Main Street core area: . . . Entertainment and cultural venues"

General Plan, Economic Goals

"Guideline 3: Pursue arts, activities, recreation opportunities and land uses that will create an experience to attract tourists"

. . . .

"Guideline 12: Promote events in the City to attract tourism"

The elegant design of the MAC honors and preserves the historic architectural theme of Midway. It will attract thousands of cultural tourists, who will contribute substantially to the success of local businesses and produce much-needed sales tax revenues. It fits

nicely in the surrounding commercial neighborhood. The MAC is a perfect example of a use that was contemplated by the framers of the General Plan.

- **REASON 2 FOR THE CHANGES - Architectural Feature**

Current Height Limitation Scheme

Occupied space is strictly limited to 35 feet. Architectural features may generally extend another 17.5 feet, but may not be occupied. Public buildings and churches may extend those limitations another 1 foot for every foot of set-back beyond the minimum.

Proposed Addition of Performing Arts Centers

The Swiss-inspired tower of the MAC, as proposed, extends beyond the 17.5-foot limitation. However, like a church or public building, to which it is very similar, the tower looks elegant and appropriate, in keeping with the Swiss/European theme of Midway. The MAC is set back sufficiently from the required distances to allow for the tower as designed, provided that the Code clarifies that indoor performing arts centers are included in the public building/churches concept.



Without this language inclusion, the tower will not have an elegant Swiss look and will not be in keeping with Midway's architectural theme. The cut-down tower will look mundane and stubby on such a beautiful structure. There is no precedential danger, as it is extremely unlikely that Midway will ever have another new indoor performing arts center.

To the Respected members of Midway's City Council:

You preside over the crossroads of the cultural heritage and future of our community. Your vision and courage are key to the success of this effort to grow the cultural climate that has been an integral part of our City since the Midway Social Hall was built in 1875. Because HVAF events already play a substantial part in the lives of Midway residents, and indeed, in the lives of many Wasatch County residents, your decision to build a permanent home for culture in Midway will affect the lives of thousands of Midway residents and their friends, now and far into the future. Hundreds of supporters are anxiously awaiting your leadership in this effort. We respectfully request that Midway City move confidently into the future and **"Bring the MAC to Midway"!**

ADDITIONAL INFORMATION AS REQUESTED

- **APPENDIX 1- PARKING**
 - Both parking options comply with Midway's parking code
- **APPENDIX 2 – TRAFFIC**
 - Traffic studies and performance history demonstrate no significant traffic impact
- **APPENDIX 3 – FUNDRAISING**
 - Experienced fundraising committee
 - Building begins once funds are legally committed
- **APPENDIX 4 - FINANCIAL PROJECTIONS**
 - Fifteen-year history and proforma projections demonstrate financial viability
- **APPENDIX 5 – GEOTECHNICAL REPORT**
 - No geotechnical impediments
- **APPENDIX 6 – CLOCK TOWER VIEW ISSUES**
 - The tower does not meaningfully restrict views
- **APPENDIX 7 – PUBLIC AND BUSINESS SUPPORT**
 - Letters from resorts, community leaders, City of Midway, and 535 Midway petition signers
- **APPENDIX 8 - FINANCIAL BENEFIT TO MIDWAY**
 - Cultural tourists will spend their money at local restaurants, gas stations, stores, and resorts. ur community
- **CONCLUDING OBSERVATIONS**
 - What will our legacy be?

APPENDIX 1 – PARKING

1:4 (1 car with 4 patrons) is the State-wide Standard for Theaters/Auditoriums

Midway's Current Standard – 1:4

- Cedar City – 1:5
- Centerville - 1:4 and 1:6
- Heber City – 1:4
- Logan – 1:4
- Orem – 1:4
- Park City – 1:4
- Provo – 1:4
- Taylorsville - 1:4
- Salt Lake City – 1:4
- Sandy – 1:4



Option 1 - Onsite and Shared



- 500 maximum occupancy
- 125 spaces required
- 68 spaces on site
- 60 spaces at Olde Swiss Square - a permanent lease agreement has been signed with the owners
- 128 total spaces

60 Shared Spaces at Olde Swiss Square



Option 2 - Fully Onsite

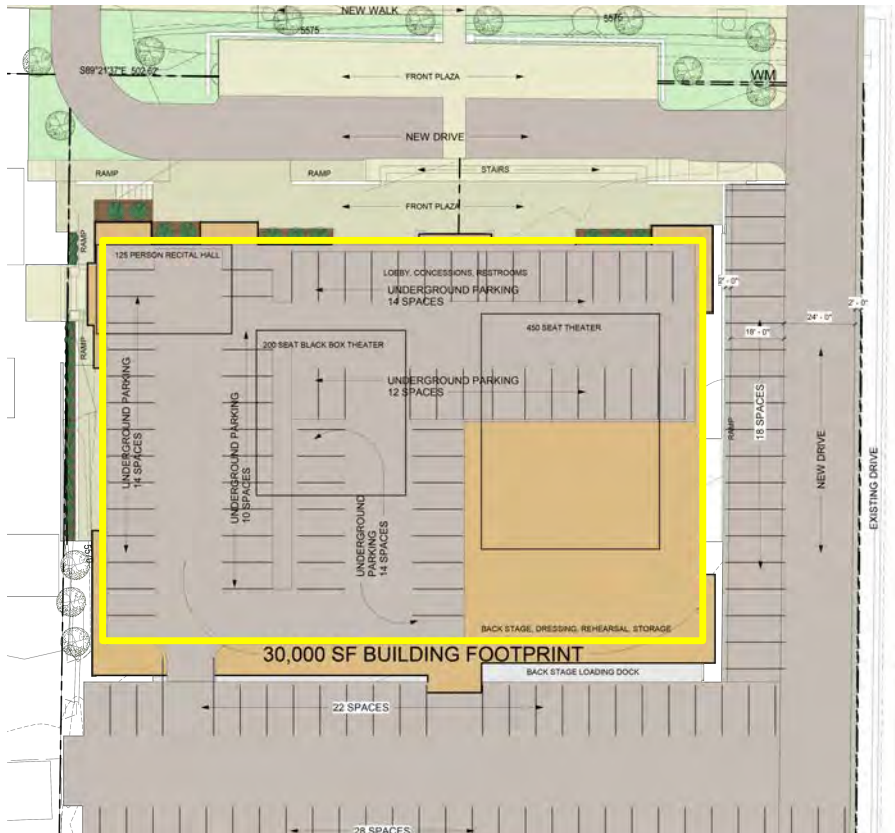

- 500 max occupancy
- 125 spaces required
- 68 spaces on perimeter
- 64 spaces under building
- 132 total parking spaces

Parking Lease with Old Swiss Square

PARKING LEASE AGREEMENT

This Agreement is entered into by and between GREENFIELD INVESTMENT, LC and/or OSSLBF,LLC ["Greenfield"], and MIDWAY ARTS CENTER FOUNDATION ["the MAC"], to be effective on the "Commencement Date," as set forth below, with regard to the following:

PRELIMINARY FACTS

1. Greenfield owns and operates the building and its associated parking facilities located at 210 E. Main Street, Midway, Utah, commonly known as the Olde Swiss Square. The parking is virtually unused in the evening hours by other tenants of the Olde Swiss Square.
2. High Valley Arts Foundation is a sister organization to the MAC and will be the resident theater company in the new MAC facility at approximately 300 E. Main Street, about a half-block away from the Olde Swiss Square parking lot.
3. High Valley Arts Foundation is a tenant in the Olde Swiss Square, with its leasehold to begin when the tenant improvements have been completed by Greenfield. The basement leasehold will be used as a "studio" for rehearsals, auditions, classes, and the like for the indefinite future.
4. The MAC has a need for additional parking beyond that which is contemplated for the new facility and Greenfield is willing to provide parking for the evening performances of the events at the MAC between the hours of 7 PM and 12 AM, pursuant to the terms that follow.

In consideration of the above, the terms below and other good and valuable consideration, the receipt of all of which is acknowledged, the parties hereto hereby agree as follows:

AGREEMENT

5. **Commencement Date.** The new MAC performing arts center is not yet constructed. The term of this agreement will commence upon the issuance of the occupancy permit for the MAC.
6. **Term.** The term of this agreement shall be for 10 years, with unlimited options of the MAC to renew the term for additional 10-year periods, in accordance with the provisions that follow.
7. **Parking Allotment.** The MAC shall be entitled to utilize 60 of the 74 parking spaces available from 7 PM to 12 AM nightly, whenever there is an event at the MAC, and for so long as the MAC is a functioning performing arts center.

WVAF JTW

8. **Rental Fees.** The basic rental fee is \$600 per month for year one with 3% annual increases, payable on the 1st of each month. For as long as High Valley Arts Foundation is a tenant of the Olde Swiss Square, The MAC will receive a discount on the rental fee based upon the percentage of the total parking to which High Valley Arts is entitled as a tenant of the building. The parties will cooperate in good faith to establish this discount in accordance with the principle just stated. In the event that High Valley Arts is no longer a tenant, the full rental fee will apply. Rent may be prepaid up to one year in advance.

9. **Option to Renew.** No later than 90 days before the expiration of any 10-year term, the MAC shall give notice in writing of its intent to renew the agreement. The rental fee for the new term shall be based upon the difference in the Bureau of Labor Statistics published Consumer Price Index, Western Region, for all items, between the commencement date of the previous term and latest CPI prior to the commencement date of the new term, but will be no less than the last years rate. The new rate will continue to have 3% annual increases through the term of the lease.

10. **Monitoring and Possible Annual Adjustment.** The parties will monitor the use of the parking and will cooperate in good faith to adjust the number of parking spaces covered by this agreement in accordance with usage requirements of the MAC and the Olde Swiss Square. However, the number of spaces shall never be less than required by the City of Midway for the operation of the MAC.

GENERAL PROVISIONS

11. **Integration.** This is the entire agreement between the parties and supersedes any prior or contemporaneous oral or written representations, agreements or promises with respect to the subject matter hereof. It may be modified only by a writing signed by the parties.

12. **Inurement.** This agreement is binding upon and inures to the benefit of the heirs, personal representatives, principals, agents, officers, partners, affiliates, owners, subsidiaries, shareholders, directors, members, managers, successors and assigns of the parties.

13. **Cooperation.** Each party agrees to sign such additional documents, provide such information, and cooperate as may be reasonably necessary to carry out the intent and purpose of this Agreement.

14. **Counterparts and Delivery.** This Agreement may be executed in counterparts, in which case all counterparts taken together shall be one Agreement. It may be delivered by .pdf attachment to an email, by fax, by mail, by overnight delivery service or by personal delivery.

AMF STU

15. **Warranty of Authority.** Each person signing this Agreement on behalf of a party hereby warrants and affirms that he or she is fully authorized to do so by his or her principal.

16. **Delivery of Notices.** Notices required under this Agreement may be given in person, by text message, by email, or by next business day overnight mail service. Notices shall be effective as follows:

15.1 if in person or by text message, on the day of delivery;

15.2 if by email or overnight delivery, on the next business day following transmission or delivery to the overnight delivery service.

SIGNATURES

GREENFIELD INVESTMENTS, LC/ OSSLB, LLC

By: 
William Fairbanks, Authorized Agent
bill@gfiutah.com

MIDWAY ARTS CENTER FOUNDATION

By: 
Susan T. Waldrip, President
suewaldrip@me.com

APPENDIX 2 – TRAFFIC

Available Data and Experience

1. Many years of High Valley Arts performance experience at identical maximum occupancy and traffic levels has shown no significant traffic congestion.
2. MAC traffic will be at off-peak hours (IN: 7:00-7:30 pm; OUT: after 9 pm) – 125 cars can clear in 10 minutes with an average of ~5 seconds per car.
3. There will be an increase in the number of events per year, but not an increase in the traffic level per event.
4. An additional traffic impact study can be performed for the MAC as needed.



**Midway Arts Center
Foundation
Parking Study**

Midway Arts Center Foundation

March, 2022

Ryan Hales, PE, PTOE, AICP

Midway Arts Center (MAC)

- Maximum venue seating
 - Main Stage = 450 seats
 - Black Box = 225 seats
 - Recital Hall = 125 seats
 - Large Rehearsal Hall
 - Smaller Rehearsal Hall
 - Dressing Rooms
- 40 Actors / stage-hands
- 10 staff / ticket takers
- The MAC will only run one theater at a time
- Start time will be consistent with other theater venues in Utah
 - 7:30 pm start
 - After peak traffic flows
- Distribution will be 50% from north (Salt Lake, Park City), and 50% from the south (Orem, Provo)

MAC - Maximum Event Trip Generation

Midway Arts Center Trip Generation							
P.M. Peak Hour Land Use ¹	Number of People ²	Trip Generation	% Entering	% Exiting	Trips Entering	Trips Exiting	Total p.m. Trips
Live Theater (Patrons) ²	450	180	96%	4%	173	7	180
Live Theater (Actors, stage hands, staff) ³	50	50	90%	0%	45	0	45
Project Total p.m. Peak Hour Trips					218	7	225

1. Land use information provided by the High Valley Arts Foundation
 2. Assume 2.5 people per vehicle
 3. Assume 1 person per vehicle, however; this group will arrive before the event in loading begins
 SOURCE: Hales Engineering, 2020

MAC - Event Trip Distribution

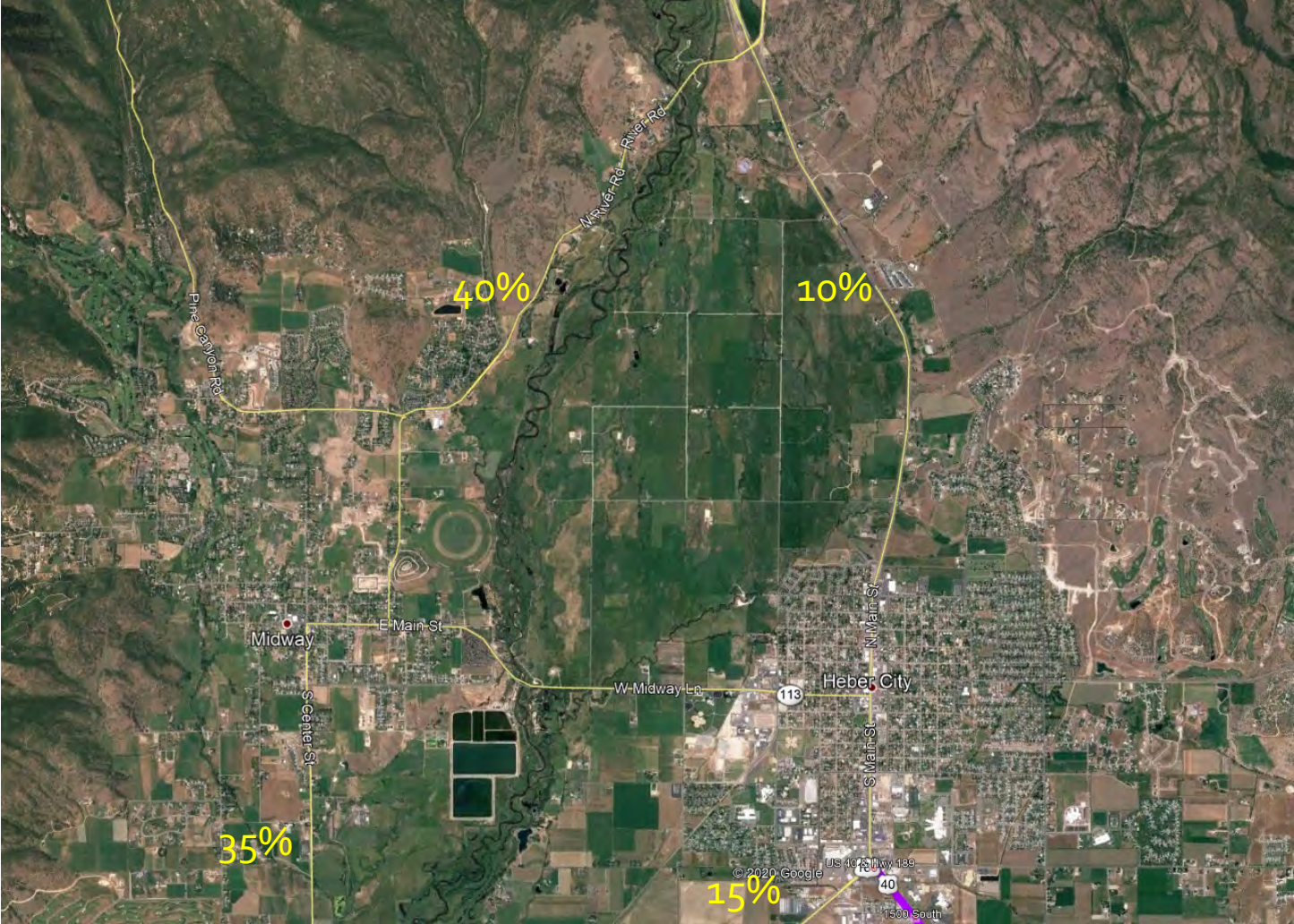

MAC - Event Trip Distribution (in-load)

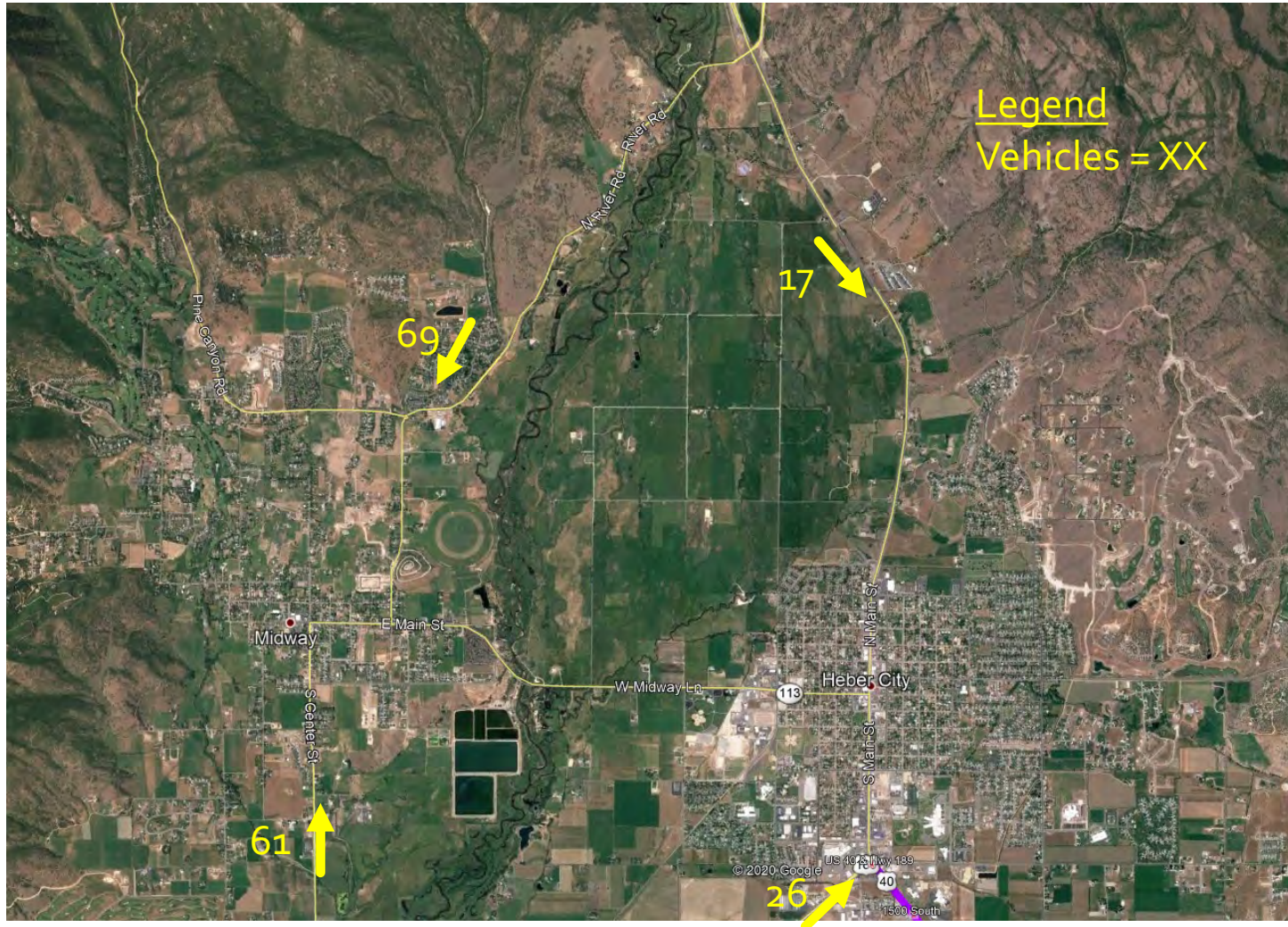

Project Accessibility



**Dan Luster Village
Traffic Impact
Study**

The Village

Traffic Impact Study



Midway, Utah

December 20, 2021

UT21-1835

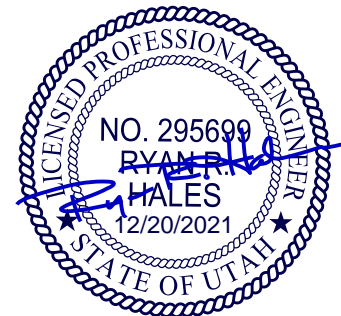

EXECUTIVE SUMMARY

This study addresses the traffic impacts associated with the proposed The Village development located in Midway, Utah. The Village project is located on the north side of Main Street, east of River Road.

The purpose of this traffic impact study is to analyze traffic operations at key intersections for existing (2021) conditions with and without the proposed project and to recommend mitigation measures as needed. The evening peak hour level of service (LOS) results are shown in Table ES-1. Recommended storage lengths are shown in Table ES-2.

Table ES-1: Evening Peak Hour Level of Service Results

Intersection	Level of Service		
	Existing (2021)		
	Background	Mitigated Background	Plus Project
1 River Road / Main Street (S.R. 113)	e	A	A
2 Fox Den Road / Main Street (S.R. 113)	b	b	c
3 580 East / Main Street (S.R. 113)	b	b	c
4 670 East / Main Street (S.R. 113)	a	b	b
5 Access 1 / Main Street (S.R. 113)	-	-	c
6 Access 3 / River Road	-	-	a

1. Intersection LOS values represent the overall intersection average for roundabout, signalized, and all-way stop-controlled (AWSC) intersections (uppercase letter) and the worst movement for all other unsignalized intersections (lowercase letter)
2. BG = Background (without project traffic), PP = Plus Project (with project traffic)

Source: Hales Engineering, December 2021

Table ES-2: Recommended Storage Lengths

Intersection	Recommended Storage Lengths (feet)															
	Northbound				Southbound				Eastbound				Westbound			
	LT		RT		LT		RT		LT		RT		LT		RT	
	E	P	E	P	E	P	E	P	E	P	E	P	E	P	E	P
1 580 East / Main Street (S.R. 113)	-	-	-	-	-	-	-	-	-	-	100	-	-	-	-	50
5 Access 1 / Main Street (S.R. 113)	-	-	-	-	-	-	-	-	-	-	100	-	-	-	-	-

1. Storage lengths are based on 2021 95th percentile queue lengths and do not include required deceleration / taper distances
2. E = Existing storage length (approximate), if applicable; P = proposed storage length for new turn lanes or changes to existing turn lanes, if applicable

Source: Hales Engineering, December 2021

SUMMARY OF KEY FINDINGS & RECOMMENDATIONS

Project Conditions

- The development will consist of residential townhome and single-family units and some commercial
- The project is anticipated to generate approximately 4,412 new weekday daily trips, including 302 trips in the morning peak hour, and 395 trips in the evening peak hour

2021	Background	Plus Project
Assumptions	<ul style="list-style-type: none"> • Traffic volumes from Whitaker Farms, Remund Farms, Indian Summer, Alder Meadows, Midway Crest, and St Prex developments added 	<ul style="list-style-type: none"> • 580 East / Main St (S.R. 113): Construct EB left-turn pocket and stripe WB right-turn pocket • West Access / Main St (S.R. 113): Construct EB left-turn pocket
Findings	<ul style="list-style-type: none"> • Poor LOS at the River Rd / Main St (S.R. 113) intersection 	<ul style="list-style-type: none"> • Acceptable LOS
Mitigations	<ul style="list-style-type: none"> • River Rd / Main St (S.R. 113): Install signal, left-turn pockets on all approaches, and right-turn pockets on EB and WB approaches. It is estimated that approximately 11% of volumes through this intersection will be project-related when the project is complete. 	<ul style="list-style-type: none"> • None are needed. While the Access 3 / River Road intersection works well operationally, River Road could benefit from a southbound left-turn pocket to separate these movements.

TABLE OF CONTENTS

EXECUTIVE SUMMARY i

SUMMARY OF KEY FINDINGS & RECOMMENDATIONS ii

TABLE OF CONTENTS iii

LIST OF TABLES iv

LIST OF FIGURES iv

I. INTRODUCTION 1

A. Purpose 1

B. Scope 2

C. Analysis Methodology 2

D. Level of Service Standards 2

II. EXISTING (2021) BACKGROUND CONDITIONS..... 4

A. Purpose 4

B. Roadway System 4

C. Traffic Volumes 4

D. Level of Service Analysis 5

E. Queuing Analysis 5

F. Mitigation Measures 5

III. PROJECT CONDITIONS 8

A. Purpose 8

B. Project Description 8

C. Trip Generation 8

D. Trip Distribution and Assignment 9

E. Access 12

F. Auxiliary Lane Requirements 12

IV. EXISTING (2021) PLUS PROJECT CONDITIONS 13

A. Purpose 13

B. Traffic Volumes 13

C. Level of Service Analysis 13

D. Queuing Analysis 13

E. Mitigation Measures 13

F. Recommended Storage Lengths 13

Appendix A: Turning Movement Counts

Appendix B: LOS Results

Appendix C: Project Site Plan

Appendix D: Queuing Results

LIST OF TABLES

Table 1: Level of Service Description 3
Table 2: Existing (2021) Background Evening Peak Hour LOS 7
Table 3: Mitigated Existing (2021) Background Evening Peak Hour LOS 7
Table 4: Project Land Uses 8
Table 5: Trip Generation 9
Table 6: Trip Distribution 10
Table 7: Auxiliary Lane Summary – Access 1 12
Table 8: Auxiliary Lane Summary – Access 2 12
Table 9: Existing (2021) Plus Project Evening Peak Hour LOS 14
Table 10: Recommended Storage Lengths 14

LIST OF FIGURES

Figure 1: Vicinity map showing the project location in Midway, Utah 1
Figure 2: Existing (2021) background evening peak hour traffic volumes 6
Figure 3: Trip assignment for the evening peak hour 11
Figure 4: Existing (2021) plus project evening peak hour traffic volumes 15

I. INTRODUCTION

A. Purpose

This study addresses the traffic impacts associated with the proposed The Village development located in Midway, Utah. The proposed project is located on the north side of Main Street, east of River Road. Figure 1 shows a vicinity map of the proposed development.

The purpose of this traffic impact study is to analyze traffic operations at key intersections for existing (2021) conditions with and without the proposed project and to recommend mitigation measures as needed.



Figure 1: Vicinity map showing the project location in Midway, Utah

B. Scope

The study area was defined based on conversations with the development team. This study was scoped to evaluate the traffic operational performance impacts of the project on the following intersections:

- River Road / Main Street (S.R. 113)
- Fox Den Road / Main Street (S.R. 113)
- 580 East / Main Street (S.R. 113)
- 670 East / Main Street (S.R. 113)

C. Analysis Methodology

Level of service (LOS) is a term that describes the operating performance of an intersection or roadway. LOS is measured quantitatively and reported on a scale from A to F, with A representing the best performance and F the worst. Table 1 provides a brief description of each LOS letter designation and an accompanying average delay per vehicle for both signalized and unsignalized intersections.







The *Highway Capacity Manual* (HCM), 6th Edition, 2016 methodology was used in this study to remain consistent with “state-of-the-practice” professional standards. This methodology has different quantitative evaluations for signalized and unsignalized intersections. For signalized, roundabout, and all-way stop-controlled (AWSC) intersections, the LOS is provided for the overall intersection (weighted average of all approach delays). For all other unsignalized intersections, LOS is reported based on the worst movement.

Using Synchro/SimTraffic software, which follow the HCM methodology, the peak hour LOS was computed for each study intersection. Multiple runs of SimTraffic were used to provide a statistical evaluation of the interaction between the intersections. The detailed LOS reports are provided in Appendix B. Hales Engineering also calculated the 95th percentile queue lengths for the study intersections using SimTraffic. The detailed queue length reports are provided in Appendix D.

D. Level of Service Standards

For the purposes of this study, a minimum acceptable intersection performance for each of the study intersections was set at LOS D. If levels of service E or F conditions exist, an explanation and/or mitigation measures will be presented. A LOS D threshold is consistent with “state-of-the-practice” traffic engineering principles for urbanized areas.

Table 1: Level of Service Description

LOS	Description of Traffic Conditions	Average Delay (seconds/vehicle)	
		Signalized Intersections	Unsignalized Intersections
A 	Free Flow / Insignificant Delay	≤ 10	≤ 10
B 	Stable Operations / Minimum Delays	> 10 to 20	> 10 to 15
C 	Stable Operations / Acceptable Delays	> 20 to 35	> 15 to 25
D 	Approaching Unstable Flows / Tolerable Delays	> 35 to 55	> 25 to 35
E 	Unstable Operations / Significant Delays	> 55 to 80	> 35 to 50
F 	Forced Flows / Unpredictable Flows / Excessive Delays	> 80	> 50

Source: Hales Engineering Descriptions, based on the *Highway Capacity Manual* (HCM), 6th Edition, 2016 Methodology (Transportation Research Board)

II. EXISTING (2021) BACKGROUND CONDITIONS

A. Purpose

The purpose of the background analysis is to study the intersections and roadways during the peak travel periods of the day with background traffic and geometric conditions. Through this analysis, background traffic operational deficiencies can be identified, and potential mitigation measures recommended. This analysis provides a baseline condition that may be compared to the build conditions to identify the impacts of the development.

B. Roadway System

The primary roadways that will provide access to the project site are described below:

Main Street (S.R. 113) – is a state-maintained roadway (classified by UDOT access management standards as a “Community – Urban Importance” facility, or access category 8 roadway). Main Street (S.R. 113) has one travel lane in each direction. As identified and controlled by UDOT, a “Community – Urban Importance” access classification identifies minimum signalized intersection spacing of one-quarter mile (1,320 feet), minimum unsignalized street spacing of 300 feet, and minimum driveway spacing of 150 feet. The posted speed limit on Main Street (S.R. 113) is 35 mph.

River Road – is a city-maintained roadway. The roadway has one travel lane in each direction. The posted speed limit is 25 mph in the study area.

C. Traffic Volumes

Weekday morning (7:00 to 9:00 a.m.) and evening (4:00 to 6:00 p.m.) peak period traffic counts were performed at the following intersections:

- River Road / Main Street (S.R. 113)
- Fox Den Road / Main Street (S.R. 113)
- 580 East / Main Street (S.R. 113)
- 670 East / Main Street (S.R. 113)

The counts were performed on Thursday, February 4, Tuesday, February 9, and Tuesday, May 25, 2021. The morning peak hour was determined to be between 7:30 and 8:30 a.m., and the evening peak hour was determined to be between 5:00 and 6:00 p.m. The evening peak hour volumes were approximately 22% higher than the morning peak hour volumes. Therefore, the evening peak hour volumes were used in the analysis to represent the worst-case conditions. Detailed count data are included in Appendix A.

The traffic counts were collected during the COVID-19 pandemic when traffic volumes were slightly reduced due to social distancing measures. According to the UDOT Automatic Traffic

Signal Performance Measures (ATSPM) website, the traffic volumes on February 6, 2020 (pre-social distancing) were approximately 17% higher than those on February 4, 2021. Therefore, the collected data were increased by 17% to represent normal conditions.

Traffic volumes were added from other incomplete or planned developments, including the following:

- Whitaker Farms
- Remund Farms
- Indian Summer
- Alder Meadows
- Midway Crest
- St Prex

These additional developments are estimated to generate approximately 188 trips during the evening peak hour, which were assigned to various routes.

Figure 2 shows the existing evening peak hour volumes as well as intersection geometry at the study intersections.

D. Level of Service Analysis

Hales Engineering determined that the River Road / Main Street (S.R. 113) intersection currently operates at a poor LOS during the evening peak hour, as shown in Table 2. These results serve as a baseline condition for the impact analysis of the proposed development during existing (2021) conditions.

E. Queuing Analysis

Hales Engineering calculated the 95th percentile queue lengths for each of the study intersections. No significant queuing was observed during the evening peak hour.

F. Mitigation Measures

According to UDOT guidelines, a traffic signal is warranted at the River Road / Main Street (S.R. 113) intersection. Because it performs at a poor LOS, it is recommended that one be installed. This may require some widening at the intersection to accommodate separate left-turn pockets on all approaches and right-turn pockets on the east- and westbound approaches.

With the proposed improvement, it is anticipated that all study intersections will perform at an acceptable LOS, as shown in Table 3.



Table 2: Existing (2021) Background Evening Peak Hour LOS

Intersection		Level of Service		
Description	Control	Movement ¹	Aver. Delay (Sec. / Veh.)	LOS ²
River Road / Main Street (S.R. 113)	NB/SB Stop	SBL	41.3	e
Fox Den Road / Main Street (S.R. 113)	NB Stop	NBL	11.2	b
580 East / Main Street (S.R. 113)	NB Stop	NBL	11.3	b
670 East / Main Street (S.R. 113)	SB Stop	SBL	10.0	a

1. Movement indicated for unsignalized intersections where delay and LOS represents worst movement. SBL = Southbound left movement, etc.

2. Uppercase LOS used for signalized, roundabout, and AWSC intersections. Lowercase LOS used for all other unsignalized intersections.

Source: Hales Engineering, October 2021

Table 3: Mitigated Existing (2021) Background Evening Peak Hour LOS

Intersection		Level of Service		
Description	Control	Movement ¹	Aver. Delay (Sec. / Veh.)	LOS ²
River Road / Main Street (S.R. 113)	Signal	-	8.1	A
Fox Den Road / Main Street (S.R. 113)	NB Stop	NBL	12.3	b
580 East / Main Street (S.R. 113)	NB Stop	NBL	12.8	b
670 East / Main Street (S.R. 113)	SB Stop	SBL	10.9	b

1. Movement indicated for unsignalized intersections where delay and LOS represents worst movement. SBL = Southbound left movement, etc.

2. Uppercase LOS used for signalized, roundabout, and AWSC intersections. Lowercase LOS used for all other unsignalized intersections.

Source: Hales Engineering, October 2021

III. PROJECT CONDITIONS

A. Purpose

The project conditions discussion explains the type and intensity of development. This provides the basis for trip generation, distribution, and assignment of project trips to the surrounding study intersections defined in Chapter I.

B. Project Description

The proposed The Village development is located on the north side of Main Street, east of River Road. The development will consist of residential townhome and single-family units and some commercial, including retail, restaurant(s), office, and a clubhouse. A concept plan for the proposed development is provided in Appendix C. The commercial square footage used for this study is conservatively high to account for the possibility that additional space may be constructed. The proposed land use for the development has been identified in Table 4.

Table 4: Project Land Uses

Land Use	Intensity
Townhomes	143 Units
Retail	10,200 sq. ft.
Restaurant	23,900 sq. ft.
Office	11,100 sq. ft.
Health/Fitness Club	37,900 sq. ft.

C. Trip Generation

Trip generation for the development was calculated using trip generation rates published in the Institute of Transportation Engineers (ITE), *Trip Generation*, 10th Edition, 2017. Due to the mixed-use nature of the development, it is likely that several trips will be made via walking internally. Based on standard ITE methodology, mixed-use trip reductions of 8% and 38% were calculated for the morning and evening peak hour, respectively. These reductions were applied to all but the clubhouse land use as this type does not have its own field in the methodology. To be conservative, the evening peak hour reduction was lowered to 30%. For the clubhouse, because the HOA is anticipated to include memberships in its fees, it was assumed that approximately 12% of trips to and from it would be internal to keep the number of internal trips consistent with the prior square footage. Trip generation for the proposed project is included in Table 5.

The total new trip generation for the development is as follows:

- Daily Trips: 4,672
- Morning Peak Hour Trips: 300
- Evening Peak Hour Trips: 386

Table 5: Trip Generation

Trip Generation Midway - The Village TIS											
Weekday Daily Land Use ¹	# of Units	Unit Type	Trip Generation	% Entering	% Exiting	Trips Entering	Trips Exiting	Internal Capture	New Trips Entering	New Trips Exiting	Total New Daily Trips
Multifamily Housing (Low-Rise) (220)	143	Dwelling Units	1,042	50%	50%	521	521	19%	422	422	844
Shopping Center (820)	10.2	1,000 Sq. Ft. GLA	1,274	50%	50%	637	637	19%	516	516	1,032
Quality Restaurant (931)	23.9	1,000 Sq. Ft. GFA	2,004	50%	50%	1,002	1,002	19%	812	812	1,624
General Office Building (710)	11.1	1,000 Sq. Ft. GFA	126	50%	50%	63	63	19%	51	51	102
Health/Fitness Club (492)	37.9	1,000 Sq. Ft. GFA	1,320	50%	50%	660	660	19%	535	535	1,070
Total			5,766			2,883	2,883		2,336	2,336	4,672
Morning Peak Hour Land Use ¹	# of Units	Unit Type	Trip Generation	% Entering	% Exiting	Trips Entering	Trips Exiting	Internal Capture	New Trips Entering	New Trips Exiting	Total New AM Trips
Multifamily Housing (Low-Rise) (220)	143	Dwelling Units	68	23%	77%	16	52	8%	15	48	63
Shopping Center (820)	10.2	1,000 Sq. Ft. GLA	158	62%	38%	98	60	8%	90	55	145
Quality Restuarant (931)	23.9	1,000 Sq. Ft. GFA	18	50%	50%	9	9	8%	8	8	16
General Office Building (710)	11.1	1,000 Sq. Ft. GFA	38	86%	14%	33	5	8%	30	5	35
Health/Fitness Club (492)	37.9	1,000 Sq. Ft. GFA	50	51%	49%	26	25	20%	21	20	41
Total			332			182	151		164	136	300
Evening Peak Hour Land Use ¹	# of Units	Unit Type	Trip Generation	% Entering	% Exiting	Trips Entering	Trips Exiting	Internal Capture	New Trips Entering	New Trips Exiting	Total New PM Trips
Multifamily Housing (Low-Rise) (220)	143	Dwelling Units	82	63%	37%	52	30	30%	36	21	57
Shopping Center (820)	10.2	1,000 Sq. Ft. GLA	102	48%	52%	49	53	30%	34	37	71
Quality Restuarant (931)	23.9	1,000 Sq. Ft. GFA	188	67%	33%	126	62	30%	88	43	131
General Office Building (710)	11.1	1,000 Sq. Ft. GFA	16	16%	84%	3	13	30%	2	9	11
Health/Fitness Club (492)	37.9	1,000 Sq. Ft. GFA	132	57%	43%	75	57	12%	66	50	116
Total			520			305	215		226	160	386

1. Land Use Code from the Institute of Transportation Engineers (ITE) *Trip Generation*, 10th Edition, 2017.

SOURCE: Hales Engineering, December 2021

D. Trip Distribution and Assignment

Project traffic is assigned to the roadway network based on the type of trip and the proximity of project access points to major streets, high population densities, and regional trip attractions. Existing travel patterns observed during data collection also provide helpful guidance to establishing these distribution percentages, especially near the site. Based on existing vehicles entering and exiting River Road, 580 East, Fox Den Road, and 670 East from Main Street (S.R. 113), and the fact that Utah County and the center of Midway draw some traffic to and from the west, the east and west ends of Main Street (S.R. 113) were given equivalent distributions. The resulting distribution of project generated trips during the evening peak hour is shown in Table 6.

Table 6: Trip Distribution

Direction	% To/From Project
North	15%
South	5%
East	40%
West	40%

These trip distribution assumptions were used to assign the evening peak hour generated traffic at the study intersections to create trip assignment for the proposed development. Trip assignment for the development is shown in Figure 3.



E. Access

The proposed access for the site will be gained at the following locations (see also concept plan in Appendix C):

Main Street (S.R. 113):

- Access 1 will be located approximately 200 feet east of the Fox Den Road / Main Street (S.R. 113) intersection. It will access the project on the north side of Main Street (S.R. 113). It is anticipated that the access will be stop-controlled.
- Access 2 will be located directly across from the 580 East / Main Street (S.R. 113) intersection. It will access the project on the north side of Main Street (S.R. 113). It is anticipated that the access will be stop-controlled.

River Road:

- Access 3 will be located approximately 880 feet north of the River Road / Main Street (S.R. 113) intersection. It will access the project on the east side of River Road. It is anticipated that the access will be stop-controlled.

F. Auxiliary Lane Requirements

UDOT Administrative Rule R930-6 outlines minimum turn volumes (measured in vehicles per hour) to warrant auxiliary lanes. It is anticipated that auxiliary lanes are required for these accesses, as shown in Table 7 and Table 8.

Table 7: Auxiliary Lane Summary – Access 1

Auxiliary Lane Type		Minimum Requirement	Measure	Met?
Left turn	Deceleration (EB-to-NB)	25 vph	67 vph	Yes
Right turn	Deceleration (WB-to-NB)	50 vph	27 vph	No

Table 8: Auxiliary Lane Summary – Access 2

Auxiliary Lane Type		Minimum Requirement	Measure	Met?
Left turn	Deceleration (EB-to-NB)	25 vph	36 vph	Yes
Right turn	Deceleration (WB-to-NB)	50 vph	63 vph	Yes

IV. EXISTING (2021) PLUS PROJECT CONDITIONS

A. Purpose

The purpose of the existing (2021) plus project analysis is to study the intersections and roadways during the peak travel periods of the day for existing background traffic and geometric conditions plus the net trips generated by the proposed development. This scenario provides valuable insight into the potential impacts of the proposed project on background traffic conditions.

B. Traffic Volumes

Hales Engineering added the project trips discussed in Chapter III to the existing (2021) background traffic volumes to predict turning movement volumes for existing (2021) plus project conditions. Existing (2021) plus project evening peak hour turning movement volumes are shown in Figure 4.

C. Level of Service Analysis

Hales Engineering determined that all study intersections are anticipated to operate at acceptable levels of service during the evening peak hour with project traffic added, as shown in Table 9.

D. Queuing Analysis

Hales Engineering calculated the 95th percentile queue lengths for each of the study intersections. No significant queuing is anticipated during the evening peak hour.

E. Mitigation Measures

No additional mitigation measures are needed. It is estimated that the portion of project-related traffic traveling through the River Road / Main Street (S.R. 113) intersection will be approximately 11%.

While the Access 3 / River Road intersection works well operationally, a southbound left-turn lane could benefit River Road by separating the lefts from the thrus so that the thrus are not impeded.

F. Recommended Storage Lengths

Hales Engineering determined recommended storage lengths based on the 95th percentile queue lengths given in the future (2021) plus project scenario. These storage lengths do not include the taper length. Recommended storage lengths for the study intersections are shown in Table 10. Intersections shown in Table 10 include new intersections and existing intersections that have recommended storage length changes.

Table 9: Existing (2021) Plus Project Evening Peak Hour LOS

Intersection		Level of Service		
Description	Control	Movement ¹	Aver. Delay (Sec. / Veh.)	LOS ²
River Road / Main Street (S.R. 113)	Signal	-	8.5	A
Fox Den Road / Main Street (S.R. 113)	NB Stop	NBL	18.5	c
580 East / Main Street (S.R. 113)	NB/SB Stop	SBL	18.2	c
670 East / Main Street (S.R. 113)	SB Stop	SBL	14.1	b
Access 1 / Main Street (S.R. 113)	SB Stop	SBL	19.5	c
Access 3 / River Road	WB Stop	WBL	8.0	a

1. Movement indicated for unsignalized intersections where delay and LOS represents worst movement. SBL = Southbound left movement, etc.
2. Uppercase LOS used for signalized, roundabout, and AWSC intersections. Lowercase LOS used for all other unsignalized intersections.

Source: Hales Engineering, October 2021

Table 10: Recommended Storage Lengths

Intersection	Recommended Storage Lengths (feet)																
	Northbound				Southbound				Eastbound				Westbound				
	LT		RT		LT		RT		LT		RT		LT		RT		
	E	P	E	P	E	P	E	P	E	P	E	P	E	P	E	P	
1	580 East / Main Street (S.R. 113)	-	-	-	-	-	-	-	-	-	-	-	-	-	-	-	50
5	Access 1 / Main Street (S.R. 113)	-	-	-	-	-	-	-	-	-	-	-	-	-	-	-	-

1. Storage lengths are based on 2021 95th percentile queue lengths and do not include required deceleration / taper distances

2. E = Existing storage length (approximate), if applicable; P = proposed storage length for new turn lanes or changes to existing turn lanes, if applicable

Source: Hales Engineering, December 2021



APPENDIX A

Turning Movement Counts



Intersection Turning Movement Summary

Intersection: River Road / Main Street
North/South: River Road
East/West: Main Street
Jurisdiction: Midway
Project Title: Beaugency TIS Update
Project No: UT21-1835
Weather: Clear

Date: 2-4-21, Thu
COVID-19 Adjustment: 85.5%
Month of Year Adjustment: 100.0%
Adjustment Station #: 0
Growth Rate: 0.0%
Number of Years: 0

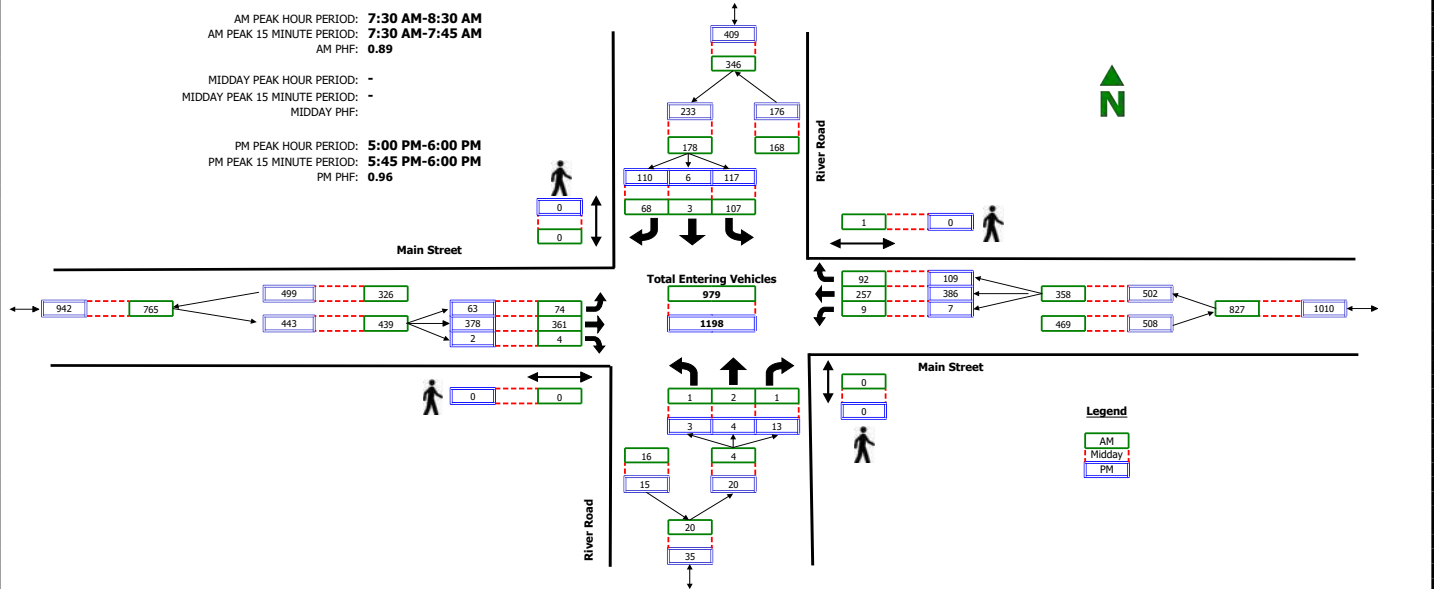

RAW COUNT SUMMARIES	River Road Northbound				River Road Southbound				Main Street Eastbound				Main Street Westbound				TOTAL
	Left	Thru	Right	Peds	Left	Thru	Right	Peds	Left	Thru	Right	Peds	Left	Thru	Right	Peds	
AM PERIOD COUNTS																	
Period	A	B	C	D	E	F	G	H	I	J	K	L	M	N	O	P	TOTAL
7:00 - 7:15	0	0	2	0	9	1	6	0	12	43	0	0	6	36	18	0	133
7:15 - 7:30	0	0	0	0	25	0	4	0	12	74	0	0	1	32	21	0	169
7:30 - 7:45	0	1	1	0	50	1	13	0	16	117	0	0	2	55	20	0	276
7:45 - 8:00	0	1	0	0	26	1	16	0	16	84	2	0	5	76	34	1	261
8:00 - 8:15	1	0	0	0	12	0	16	0	16	76	1	0	1	65	25	0	213
8:15 - 8:30	0	0	0	0	19	1	23	0	26	84	1	0	1	61	13	0	229
8:30 - 8:45	1	0	2	0	26	0	23	1	30	91	2	0	0	76	18	0	269
8:45 - 9:00	1	0	2	0	30	0	12	0	28	78	0	0	1	82	22	0	256
MIDDAY PERIOD COUNTS																	
Period	A	B	C	D	E	F	G	H	I	J	K	L	M	N	O	P	TOTAL
9:00 - 9:15	0	0	0	0	0	0	0	0	0	0	0	0	0	0	0	0	0
9:15 - 9:30	0	0	0	0	0	0	0	0	0	0	0	0	0	0	0	0	0
9:30 - 9:45	0	0	0	0	0	0	0	0	0	0	0	0	0	0	0	0	0
9:45 - 10:00	0	0	0	0	0	0	0	0	0	0	0	0	0	0	0	0	0
10:00 - 10:15	0	0	0	0	0	0	0	0	0	0	0	0	0	0	0	0	0
10:15 - 10:30	0	0	0	0	0	0	0	0	0	0	0	0	0	0	0	0	0
10:30 - 10:45	0	0	0	0	0	0	0	0	0	0	0	0	0	0	0	0	0
10:45 - 11:00	0	0	0	0	0	0	0	0	0	0	0	0	0	0	0	0	0
11:00 - 11:15	0	0	0	0	0	0	0	0	0	0	0	0	0	0	0	0	0
11:15 - 11:30	0	0	0	0	0	0	0	0	0	0	0	0	0	0	0	0	0
11:30 - 11:45	0	0	0	0	0	0	0	0	0	0	0	0	0	0	0	0	0
11:45 - 12:00	0	0	0	0	0	0	0	0	0	0	0	0	0	0	0	0	0
12:00 - 12:15	0	0	0	0	0	0	0	0	0	0	0	0	0	0	0	0	0
12:15 - 12:30	0	0	0	0	0	0	0	0	0	0	0	0	0	0	0	0	0
12:30 - 12:45	0	0	0	0	0	0	0	0	0	0	0	0	0	0	0	0	0
12:45 - 13:00	0	0	0	0	0	0	0	0	0	0	0	0	0	0	0	0	0
13:00 - 13:15	0	0	0	0	0	0	0	0	0	0	0	0	0	0	0	0	0
13:15 - 13:30	0	0	0	0	0	0	0	0	0	0	0	0	0	0	0	0	0
13:30 - 13:45	0	0	0	0	0	0	0	0	0	0	0	0	0	0	0	0	0
13:45 - 14:00	0	0	0	0	0	0	0	0	0	0	0	0	0	0	0	0	0
14:00 - 14:15	0	0	0	0	0	0	0	0	0	0	0	0	0	0	0	0	0
14:15 - 14:30	0	0	0	0	0	0	0	0	0	0	0	0	0	0	0	0	0
14:30 - 14:45	0	0	0	0	0	0	0	0	0	0	0	0	0	0	0	0	0
14:45 - 15:00	0	0	0	0	0	0	0	0	0	0	0	0	0	0	0	0	0
15:00 - 15:15	0	0	0	0	0	0	0	0	0	0	0	0	0	0	0	0	0
15:15 - 15:30	0	0	0	0	0	0	0	0	0	0	0	0	0	0	0	0	0
15:30 - 15:45	0	0	0	0	0	0	0	0	0	0	0	0	0	0	0	0	0
15:45 - 16:00	0	0	0	0	0	0	0	0	0	0	0	0	0	0	0	0	0
PM PERIOD COUNTS																	
Period	A	B	C	D	E	F	G	H	I	J	K	L	M	N	O	P	TOTAL
16:00 - 16:15	0	0	2	0	12	0	16	1	26	92	1	0	1	111	32	0	293
16:15 - 16:30	0	1	1	0	37	0	26	0	11	110	1	0	2	90	13	0	292
16:30 - 16:45	2	1	2	0	28	0	32	0	12	85	0	5	2	106	32	0	302
16:45 - 17:00	0	0	5	0	28	1	25	0	5	76	2	0	2	87	36	0	267
17:00 - 17:15	1	2	7	0	30	2	28	0	16	87	1	0	4	98	33	0	309
17:15 - 17:30	2	1	4	0	26	2	33	0	11	105	0	0	1	102	23	0	310
17:30 - 17:45	0	0	2	0	33	0	27	0	21	101	0	0	0	71	12	0	267
17:45 - 18:00	0	1	0	0	28	2	22	0	15	85	1	0	2	115	41	0	312

Intersection Turning Movement Summary

Intersection: Fox Den Road / Main Street
North/South: Fox Den Road
East/West: Main Street
Jurisdiction: Midway
Project Title: Beaugency TIS Update
Project No: UT21-1835
Weather: Clear

Date: 2-4-21, Thu
COVID-19 Adjustment: 85.5%
Month of Year Adjustment: 100.0%
Adjustment Station #: 0
Growth Rate: 0.0%
Number of Years: 0

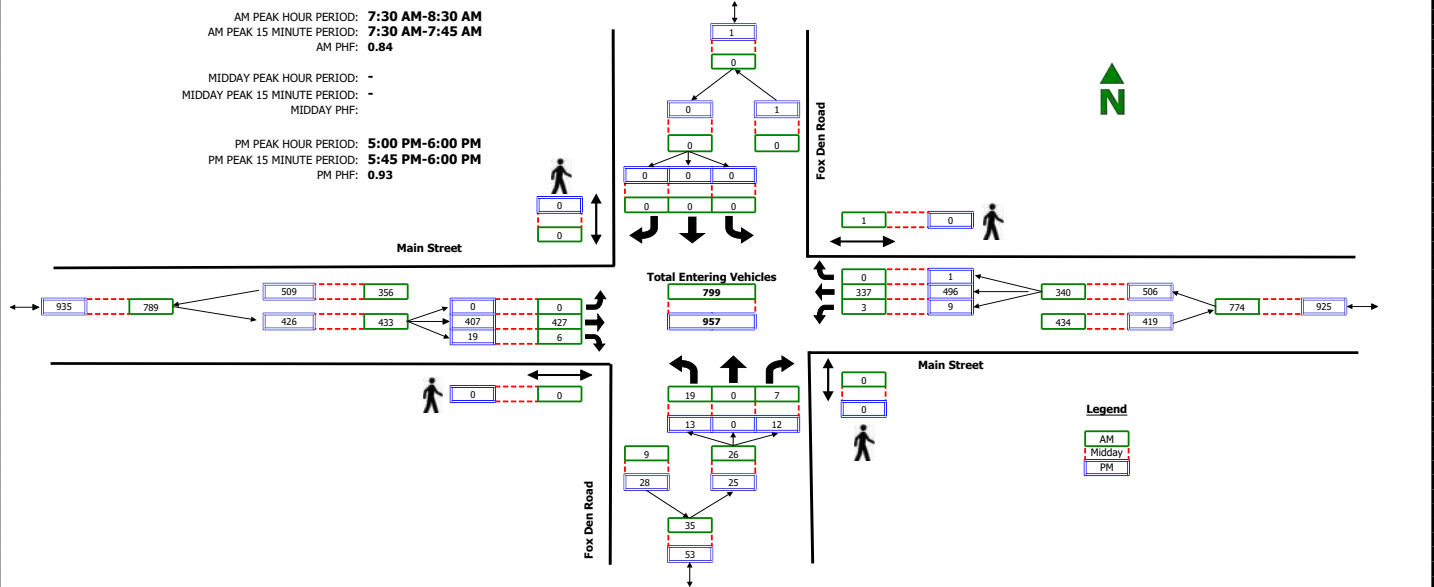

RAW COUNT SUMMARIES	Fox Den Road Northbound				Fox Den Road Southbound				Main Street Eastbound				Main Street Westbound				TOTAL
	Left	Thru	Right	Peds	Left	Thru	Right	Peds	Left	Thru	Right	Peds	Left	Thru	Right	Peds	
AM PERIOD COUNTS																	
Period	A	B	C	D	E	F	G	H	I	J	K	L	M	N	O	P	TOTAL
7:00 - 7:15	2	1	2	0	1	0	0	0	1	44	1	0	1	61	0	0	114
7:15 - 7:30	4	0	2	0	0	0	0	0	0	89	4	0	0	48	0	0	147
7:30 - 7:45	4	0	2	0	0	0	0	0	0	157	0	0	0	75	0	0	238
7:45 - 8:00	6	0	2	0	0	0	0	0	0	98	1	0	1	104	0	1	212
8:00 - 8:15	5	0	1	0	0	0	0	0	0	81	1	0	1	87	0	0	176
8:15 - 8:30	4	0	2	0	0	0	0	0	0	91	4	0	1	71	0	0	173
8:30 - 8:45	1	1	0	0	0	0	0	0	0	102	4	1	5	97	0	0	210
8:45 - 9:00	2	0	5	0	0	0	0	0	0	98	6	0	5	104	0	0	220
MIDDAY PERIOD COUNTS																	
Period	A	B	C	D	E	F	G	H	I	J	K	L	M	N	O	P	TOTAL
9:00 - 9:15	0	0	0	0	0	0	0	0	0	0	0	0	0	0	0	0	0
9:15 - 9:30	0	0	0	0	0	0	0	0	0	0	0	0	0	0	0	0	0
9:30 - 9:45	0	0	0	0	0	0	0	0	0	0	0	0	0	0	0	0	0
9:45 - 10:00	0	0	0	0	0	0	0	0	0	0	0	0	0	0	0	0	0
10:00 - 10:15	0	0	0	0	0	0	0	0	0	0	0	0	0	0	0	0	0
10:15 - 10:30	0	0	0	0	0	0	0	0	0	0	0	0	0	0	0	0	0
10:30 - 10:45	0	0	0	0	0	0	0	0	0	0	0	0	0	0	0	0	0
10:45 - 11:00	0	0	0	0	0	0	0	0	0	0	0	0	0	0	0	0	0
11:00 - 11:15	0	0	0	0	0	0	0	0	0	0	0	0	0	0	0	0	0
11:15 - 11:30	0	0	0	0	0	0	0	0	0	0	0	0	0	0	0	0	0
11:30 - 11:45	0	0	0	0	0	0	0	0	0	0	0	0	0	0	0	0	0
11:45 - 12:00	0	0	0	0	0	0	0	0	0	0	0	0	0	0	0	0	0
12:00 - 12:15	0	0	0	0	0	0	0	0	0	0	0	0	0	0	0	0	0
12:15 - 12:30	0	0	0	0	0	0	0	0	0	0	0	0	0	0	0	0	0
12:30 - 12:45	0	0	0	0	0	0	0	0	0	0	0	0	0	0	0	0	0
12:45 - 13:00	0	0	0	0	0	0	0	0	0	0	0	0	0	0	0	0	0
13:00 - 13:15	0	0	0	0	0	0	0	0	0	0	0	0	0	0	0	0	0
13:15 - 13:30	0	0	0	0	0	0	0	0	0	0	0	0	0	0	0	0	0
13:30 - 13:45	0	0	0	0	0	0	0	0	0	0	0	0	0	0	0	0	0
13:45 - 14:00	0	0	0	0	0	0	0	0	0	0	0	0	0	0	0	0	0
14:00 - 14:15	0	0	0	0	0	0	0	0	0	0	0	0	0	0	0	0	0
14:15 - 14:30	0	0	0	0	0	0	0	0	0	0	0	0	0	0	0	0	0
14:30 - 14:45	0	0	0	0	0	0	0	0	0	0	0	0	0	0	0	0	0
14:45 - 15:00	0	0	0	0	0	0	0	0	0	0	0	0	0	0	0	0	0
15:00 - 15:15	0	0	0	0	0	0	0	0	0	0	0	0	0	0	0	0	0
15:15 - 15:30	0	0	0	0	0	0	0	0	0	0	0	0	0	0	0	0	0
15:30 - 15:45	0	0	0	0	0	0	0	0	0	0	0	0	0	0	0	0	0
15:45 - 16:00	0	0	0	0	0	0	0	0	0	0	0	0	0	0	0	0	0
PM PERIOD COUNTS																	
Period	A	B	C	D	E	F	G	H	I	J	K	L	M	N	O	P	TOTAL
16:00 - 16:15	4	0	1	0	0	0	0	0	0	97	4	0	1	139	0	0	246
16:15 - 16:30	4	0	2	0	0	0	0	0	0	129	7	0	2	97	0	1	241
16:30 - 16:45	1	0	2	0	0	0	0	0	0	111	0	4	2	130	0	0	246
16:45 - 17:00	1	0	1	0	0	0	0	0	0	82	1	0	1	132	0	0	218
17:00 - 17:15	1	0	0	0	0	0	0	0	0	104	1	0	0	144	0	0	250
17:15 - 17:30	1	0	6	0	0	0	0	0	0	102	5	0	1	123	1	0	239
17:30 - 17:45	4	0	2	0	0	0	0	0	0	119	5	0	4	78	0	0	212
17:45 - 18:00	7	0	4	0	0	0	0	0	0	82	8	0	4	151	0	0	256

Intersection Turning Movement Summary

Intersection: 580 East / Main Street
North/South: 580 East
East/West: Main Street
Jurisdiction: Midway
Project Title: The Village TIS
Project No: UT21-1835
Weather: Clear

Date: 5-25-21, Tue
COVID-19 Adjustment: 85.5%
Month of Year Adjustment: 100.0%
Adjustment Station #: 0
Growth Rate: 0.0%
Number of Years: 0

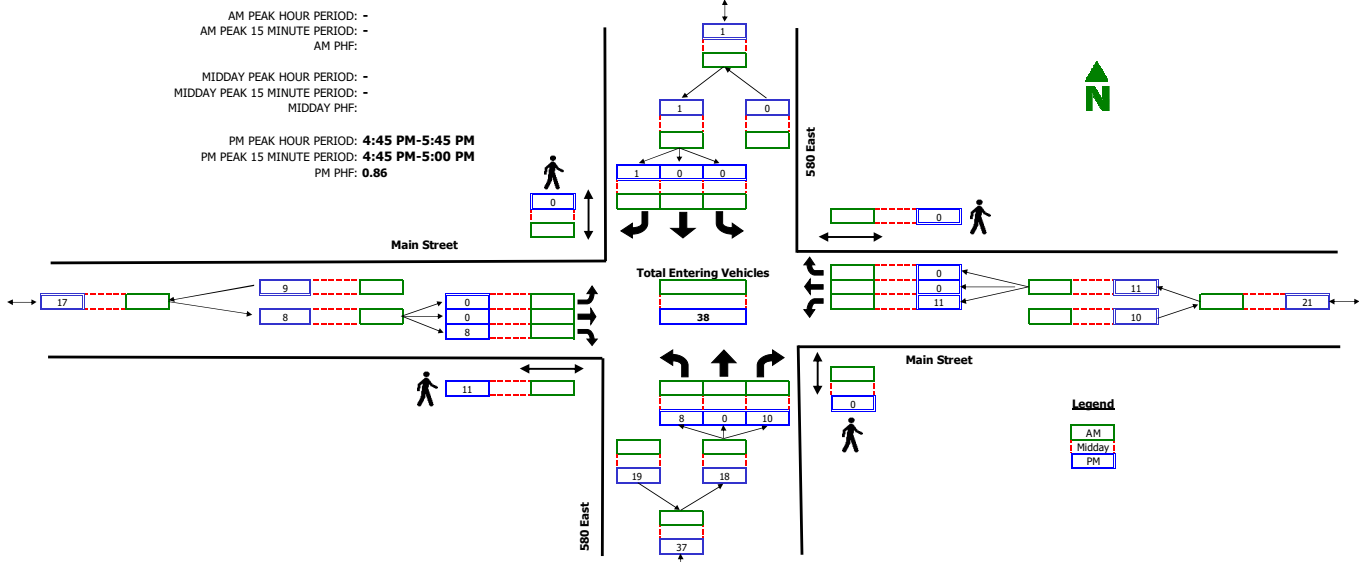

RAW COUNT SUMMARIES	580 East Northbound				580 East Southbound				Main Street Eastbound				Main Street Westbound				TOTAL
	Left	Thru	Right	Peds	Left	Thru	Right	Peds	Left	Thru	Right	Peds	Left	Thru	Right	Peds	
AM PERIOD COUNTS																	
Period	A	B	C	D	E	F	G	H	I	J	K	L	M	N	O	P	TOTAL
7:00 - 7:15	0	0	0	0	0	0	0	0	0	0	0	0	0	0	0	0	0
7:15 - 7:30	0	0	0	0	0	0	0	0	0	0	0	0	0	0	0	0	0
7:30 - 7:45	0	0	0	0	0	0	0	0	0	0	0	0	0	0	0	0	0
7:45 - 8:00	0	0	0	0	0	0	0	0	0	0	0	0	0	0	0	0	0
8:00 - 8:15	0	0	0	0	0	0	0	0	0	0	0	0	0	0	0	0	0
8:15 - 8:30	0	0	0	0	0	0	0	0	0	0	0	0	0	0	0	0	0
8:30 - 8:45	0	0	0	0	0	0	0	0	0	0	0	0	0	0	0	0	0
8:45 - 9:00	0	0	0	0	0	0	0	0	0	0	0	0	0	0	0	0	0
MIDDAY PERIOD COUNTS																	
Period	A	B	C	D	E	F	G	H	I	J	K	L	M	N	O	P	TOTAL
9:00 - 9:15	0	0	0	0	0	0	0	0	0	0	0	0	0	0	0	0	0
9:15 - 9:30	0	0	0	0	0	0	0	0	0	0	0	0	0	0	0	0	0
9:30 - 9:45	0	0	0	0	0	0	0	0	0	0	0	0	0	0	0	0	0
9:45 - 10:00	0	0	0	0	0	0	0	0	0	0	0	0	0	0	0	0	0
10:00 - 10:15	0	0	0	0	0	0	0	0	0	0	0	0	0	0	0	0	0
10:15 - 10:30	0	0	0	0	0	0	0	0	0	0	0	0	0	0	0	0	0
10:30 - 10:45	0	0	0	0	0	0	0	0	0	0	0	0	0	0	0	0	0
10:45 - 11:00	0	0	0	0	0	0	0	0	0	0	0	0	0	0	0	0	0
11:00 - 11:15	0	0	0	0	0	0	0	0	0	0	0	0	0	0	0	0	0
11:15 - 11:30	0	0	0	0	0	0	0	0	0	0	0	0	0	0	0	0	0
11:30 - 11:45	0	0	0	0	0	0	0	0	0	0	0	0	0	0	0	0	0
11:45 - 12:00	0	0	0	0	0	0	0	0	0	0	0	0	0	0	0	0	0
12:00 - 12:15	0	0	0	0	0	0	0	0	0	0	0	0	0	0	0	0	0
12:15 - 12:30	0	0	0	0	0	0	0	0	0	0	0	0	0	0	0	0	0
12:30 - 12:45	0	0	0	0	0	0	0	0	0	0	0	0	0	0	0	0	0
12:45 - 13:00	0	0	0	0	0	0	0	0	0	0	0	0	0	0	0	0	0
13:00 - 13:15	0	0	0	0	0	0	0	0	0	0	0	0	0	0	0	0	0
13:15 - 13:30	0	0	0	0	0	0	0	0	0	0	0	0	0	0	0	0	0
13:30 - 13:45	0	0	0	0	0	0	0	0	0	0	0	0	0	0	0	0	0
13:45 - 14:00	0	0	0	0	0	0	0	0	0	0	0	0	0	0	0	0	0
14:00 - 14:15	0	0	0	0	0	0	0	0	0	0	0	0	0	0	0	0	0
14:15 - 14:30	0	0	0	0	0	0	0	0	0	0	0	0	0	0	0	0	0
14:30 - 14:45	0	0	0	0	0	0	0	0	0	0	0	0	0	0	0	0	0
14:45 - 15:00	0	0	0	0	0	0	0	0	0	0	0	0	0	0	0	0	0
15:00 - 15:15	0	0	0	0	0	0	0	0	0	0	0	0	0	0	0	0	0
15:15 - 15:30	0	0	0	0	0	0	0	0	0	0	0	0	0	0	0	0	0
15:30 - 15:45	0	0	0	0	0	0	0	0	0	0	0	0	0	0	0	0	0
15:45 - 16:00	0	0	0	0	0	0	0	0	0	0	0	0	0	0	0	0	0
PM PERIOD COUNTS																	
Period	A	B	C	D	E	F	G	H	I	J	K	L	M	N	O	P	TOTAL
16:00 - 16:15	0	0	4	0	0	0	0	1	0	0	0	0	1	0	0	0	5
16:15 - 16:30	0	0	1	0	0	0	0	0	0	0	2	0	5	0	0	0	8
16:30 - 16:45	0	0	0	0	0	0	0	0	0	1	12	2	2	0	0	0	3
16:45 - 17:00	2	0	2	0	0	0	0	0	0	6	6	1	0	0	0	0	11
17:00 - 17:15	2	0	2	0	0	0	0	0	0	0	0	4	0	0	0	0	8
17:15 - 17:30	4	0	1	0	0	0	0	0	0	1	1	2	0	0	0	0	8
17:30 - 17:45	0	0	5	0	0	0	1	0	0	1	4	4	0	0	0	0	11
17:45 - 18:00	2	0	1	0	0	0	1	0	0	0	2	5	1	0	0	0	6

Intersection Turning Movement Summary

Intersection: 670 East / Main Street
North/South: 670 East
East/West: Main Street
Jurisdiction: Midway
Project Title: Beaugency TIS Update
Project No: UT21-1835
Weather: Clear

Date: 2-9-21, Tue
COVID-19 Adjustment: 85.5%
Month of Year Adjustment: 100.0%
Adjustment Station #: 0
Growth Rate: 0.0%
Number of Years: 0

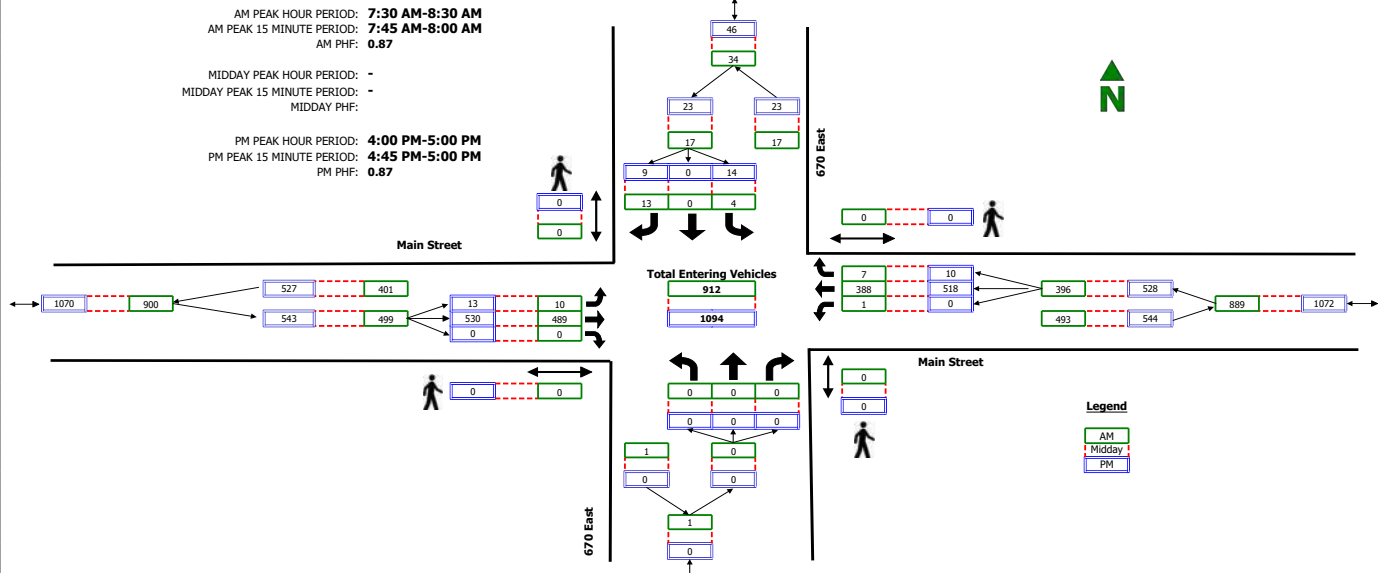

RAW COUNT SUMMARIES	670 East Northbound				670 East Southbound				Main Street Eastbound				Main Street Westbound				TOTAL
	Left	Thru	Right	Peds	Left	Thru	Right	Peds	Left	Thru	Right	Peds	Left	Thru	Right	Peds	
AM PERIOD COUNTS																	
Period	A	B	C	D	E	F	G	H	I	J	K	L	M	N	O	P	TOTAL
7:00 - 7:15	0	0	0	0	0	0	0	0	0	46	0	0	0	47	0	0	93
7:15 - 7:30	0	0	0	0	2	0	0	0	0	108	0	0	0	50	0	0	160
7:30 - 7:45	0	0	0	0	2	0	1	0	0	171	0	0	0	78	1	0	253
7:45 - 8:00	0	0	0	0	2	0	2	0	4	143	0	0	0	109	2	0	262
8:00 - 8:15	0	0	0	0	0	0	5	0	4	87	0	0	1	113	4	0	214
8:15 - 8:30	0	0	0	0	0	0	5	0	2	88	0	0	0	88	0	0	183
8:30 - 8:45	0	0	0	0	1	0	2	0	2	104	0	0	0	97	0	0	206
8:45 - 9:00	0	0	0	0	4	0	0	0	2	143	0	0	0	91	1	0	241
MIDDAY PERIOD COUNTS																	
Period	A	B	C	D	E	F	G	H	I	J	K	L	M	N	O	P	TOTAL
9:00 - 9:15	0	0	0	0	0	0	0	0	0	0	0	0	0	0	0	0	0
9:15 - 9:30	0	0	0	0	0	0	0	0	0	0	0	0	0	0	0	0	0
9:30 - 9:45	0	0	0	0	0	0	0	0	0	0	0	0	0	0	0	0	0
9:45 - 10:00	0	0	0	0	0	0	0	0	0	0	0	0	0	0	0	0	0
10:00 - 10:15	0	0	0	0	0	0	0	0	0	0	0	0	0	0	0	0	0
10:15 - 10:30	0	0	0	0	0	0	0	0	0	0	0	0	0	0	0	0	0
10:30 - 10:45	0	0	0	0	0	0	0	0	0	0	0	0	0	0	0	0	0
10:45 - 11:00	0	0	0	0	0	0	0	0	0	0	0	0	0	0	0	0	0
11:00 - 11:15	0	0	0	0	0	0	0	0	0	0	0	0	0	0	0	0	0
11:15 - 11:30	0	0	0	0	0	0	0	0	0	0	0	0	0	0	0	0	0
11:30 - 11:45	0	0	0	0	0	0	0	0	0	0	0	0	0	0	0	0	0
11:45 - 12:00	0	0	0	0	0	0	0	0	0	0	0	0	0	0	0	0	0
12:00 - 12:15	0	0	0	0	0	0	0	0	0	0	0	0	0	0	0	0	0
12:15 - 12:30	0	0	0	0	0	0	0	0	0	0	0	0	0	0	0	0	0
12:30 - 12:45	0	0	0	0	0	0	0	0	0	0	0	0	0	0	0	0	0
12:45 - 13:00	0	0	0	0	0	0	0	0	0	0	0	0	0	0	0	0	0
13:00 - 13:15	0	0	0	0	0	0	0	0	0	0	0	0	0	0	0	0	0
13:15 - 13:30	0	0	0	0	0	0	0	0	0	0	0	0	0	0	0	0	0
13:30 - 13:45	0	0	0	0	0	0	0	0	0	0	0	0	0	0	0	0	0
13:45 - 14:00	0	0	0	0	0	0	0	0	0	0	0	0	0	0	0	0	0
14:00 - 14:15	0	0	0	0	0	0	0	0	0	0	0	0	0	0	0	0	0
14:15 - 14:30	0	0	0	0	0	0	0	0	0	0	0	0	0	0	0	0	0
14:30 - 14:45	0	0	0	0	0	0	0	0	0	0	0	0	0	0	0	0	0
14:45 - 15:00	0	0	0	0	0	0	0	0	0	0	0	0	0	0	0	0	0
15:00 - 15:15	0	0	0	0	0	0	0	0	0	0	0	0	0	0	0	0	0
15:15 - 15:30	0	0	0	0	0	0	0	0	0	0	0	0	0	0	0	0	0
15:30 - 15:45	0	0	0	0	0	0	0	0	0	0	0	0	0	0	0	0	0
15:45 - 16:00	0	0	0	0	0	0	0	0	0	0	0	0	0	0	0	0	0
PM PERIOD COUNTS																	
Period	A	B	C	D	E	F	G	H	I	J	K	L	M	N	O	P	TOTAL
16:00 - 16:15	0	0	0	0	1	0	5	0	5	117	0	0	0	135	4	0	267
16:15 - 16:30	0	0	0	0	5	0	2	0	1	131	0	0	0	124	4	0	267
16:30 - 16:45	0	0	0	0	2	0	1	0	1	116	0	0	0	123	1	0	244
16:45 - 17:00	0	0	0	0	6	0	1	0	6	166	0	0	0	136	1	0	316
17:00 - 17:15	0	0	0	0	1	0	2	0	1	125	0	0	0	133	4	0	266
17:15 - 17:30	0	0	0	0	2	0	2	0	1	96	0	0	0	126	4	0	231
17:30 - 17:45	0	0	0	0	1	0	4	0	1	101	0	0	0	133	0	0	240
17:45 - 18:00	0	0	0	0	2	0	4	0	0	132	0	0	0	108	1	0	247

APPENDIX B

LOS Results

SimTraffic LOS Report

Project: Midway - The Village TIS
Analysis Period: Existing (2021) Background
Time Period: Evening Peak Hour **Project #: UT21-1835**

Intersection: River Road & Main Street
Type: Unsignalized

Approach	Movement	Demand Volume	Volume Served		Delay/Veh (sec)	
			Avg	%	Avg	LOS
NB	L	3	2	67	20.9	C
	T	4	3	75	26.5	D
	R	13	13	98	7.3	A
	Subtotal	20	18	90	12.0	B
SB	L	140	138	99	41.3	E
	T	6	4	67	35.2	E
	R	137	138	101	7.6	A
	Subtotal	283	280	99	24.6	C
EB	L	106	103	97	7.6	A
	T	386	380	98	4.0	A
	R	2	2	100	4.2	A
	Subtotal	494	485	98	4.8	A
WB	L	7	5	71	5.3	A
	T	410	426	104	2.8	A
	R	146	150	103	1.3	A
	Subtotal	563	581	103	2.4	A
Total		1,360	1,364	100	8.0	A

Intersection: Fox Den Road & Main Street
Type: Unsignalized

Approach	Movement	Demand Volume	Volume Served		Delay/Veh (sec)	
			Avg	%	Avg	LOS
NB	L	14	14	98	11.2	B
	R	12	12	98	4.9	A
	Subtotal	26	26	100	8.3	A
EB	T	526	520	99	1.3	A
	R	21	20	94	1.0	A
	Subtotal	547	540	99	1.3	A
WB	L	9	7	78	4.1	A
	T	541	556	103	1.0	A
	Subtotal	550	563	102	1.0	A
Total		1,124	1,129	100	1.3	A

SimTraffic LOS Report

Project: Midway - The Village TIS
Analysis Period: Existing (2021) Background
Time Period: Evening Peak Hour **Project #: UT21-1835**

Intersection: 580 East & Main Street
Type: Unsignalized

Approach	Movement	Demand Volume	Volume Served		Delay/Veh (sec)	
			Avg	%	Avg	LOS
NB	L	8	8	100	11.3	B
	R	10	13	130	5.1	A
	Subtotal	18	21	117	7.5	A
EB	T	523	515	99	0.8	A
	R	8	8	100	0.5	A
	Subtotal	531	523	98	0.8	A
WB	L	11	10	91	4.0	A
	T	542	556	103	0.6	A
	Subtotal	553	566	102	0.7	A
Total		1,102	1,110	101	0.9	A

Intersection: Main Street & 670 East
Type: Unsignalized

Approach	Movement	Demand Volume	Volume Served		Delay/Veh (sec)	
			Avg	%	Avg	LOS
SB	L	14	14	98	10.0	A
	R	9	10	111	5.7	A
	Subtotal	23	24	104	8.2	A
EB	L	13	14	106	3.5	A
	T	520	515	99	0.6	A
	Subtotal	533	529	99	0.7	A
WB	T	544	557	102	1.3	A
	R	10	10	100	1.2	A
	Subtotal	554	567	102	1.3	A
Total		1,110	1,120	101	1.2	A

SimTraffic LOS Report

Project: Midway - The Village TIS
Analysis Period: Mitigated Existing (2021) Background
Time Period: Evening Peak Hour **Project #: UT21-1835**

Intersection: River Road & Main Street
Type: Signalized

Approach	Movement	Demand Volume	Volume Served		Delay/Veh (sec)	
			Avg	%	Avg	LOS
NB	L	3	3	100	12.6	B
	T	4	4	100	7.1	A
	R	13	14	106	4.6	A
	Subtotal	20	21	105	6.2	A
SB	L	140	140	100	13.4	B
	T	6	7	117	9.0	A
	R	137	132	96	5.4	A
	Subtotal	283	279	99	9.5	A
EB	L	106	107	101	16.5	B
	T	386	386	100	7.3	A
	R	2	3	150	1.5	A
	Subtotal	494	496	100	9.2	A
WB	L	7	6	86	11.7	B
	T	410	395	96	7.5	A
	R	146	147	101	3.3	A
	Subtotal	563	548	97	6.4	A
Total		1,360	1,344	99	8.1	A

Intersection: Fox Den Road & Main Street
Type: Unsignalized

Approach	Movement	Demand Volume	Volume Served		Delay/Veh (sec)	
			Avg	%	Avg	LOS
NB	L	14	15	105	12.3	B
	R	12	14	114	4.6	A
	Subtotal	26	29	112	8.6	A
EB	T	526	527	100	1.9	A
	R	21	21	99	1.5	A
	Subtotal	547	548	100	1.9	A
WB	L	9	10	111	4.3	A
	T	541	525	97	1.2	A
	Subtotal	550	535	97	1.3	A
Total		1,124	1,112	99	1.8	A

SimTraffic LOS Report

Project: Midway - The Village TIS
Analysis Period: Mitigated Existing (2021) Background
Time Period: Evening Peak Hour **Project #: UT21-1835**

Intersection: 580 East & Main Street
Type: Unsignalized

Approach	Movement	Demand Volume	Volume Served		Delay/Veh (sec)	
			Avg	%	Avg	LOS
NB	L	8	9	112	12.8	B
	R	10	10	100	5.5	A
	Subtotal	18	19	106	9.0	A
EB	T	523	525	100	0.9	A
	R	8	8	100	0.4	A
	Subtotal	531	533	100	0.9	A
WB	L	11	11	100	4.1	A
	T	542	525	97	0.7	A
	Subtotal	553	536	97	0.8	A
Total		1,102	1,088	99	0.9	A

Intersection: Main Street & 670 East
Type: Unsignalized

Approach	Movement	Demand Volume	Volume Served		Delay/Veh (sec)	
			Avg	%	Avg	LOS
SB	L	14	13	91	10.9	B
	R	9	10	111	5.1	A
	Subtotal	23	23	100	8.4	A
EB	L	13	12	91	3.8	A
	T	520	523	101	0.7	A
	Subtotal	533	535	100	0.8	A
WB	T	544	526	97	1.3	A
	R	10	10	100	0.7	A
	Subtotal	554	536	97	1.3	A
Total		1,110	1,094	99	1.2	A

SimTraffic LOS Report

Project: Midway - The Village TIS
Analysis Period: Existing (2021) Plus Project
Time Period: Evening Peak Hour **Project #: UT21-1835**

Intersection: River Road & Main Street
Type: Signalized

Approach	Movement	Demand Volume	Volume Served		Delay/Veh (sec)	
			Avg	%	Avg	LOS
NB	L	3	2	67	16.4	B
	T	4	3	75	14.5	B
	R	13	14	106	5.2	A
	Subtotal	20	19	95	7.8	A
SB	L	146	144	99	15.0	B
	T	6	5	83	13.0	B
	R	140	138	99	6.8	A
	Subtotal	292	287	98	11.0	B
EB	L	111	107	97	17.7	B
	T	471	477	101	7.9	A
	R	2	2	100	2.4	A
	Subtotal	584	586	100	9.7	A
WB	L	7	6	86	11.7	B
	T	471	475	101	7.2	A
	R	151	155	103	3.2	A
	Subtotal	629	636	101	6.3	A
Total		1,525	1,528	100	8.5	A

Intersection: Fox Den Road & Main Street
Type: Unsignalized

Approach	Movement	Demand Volume	Volume Served		Delay/Veh (sec)	
			Avg	%	Avg	LOS
NB	L	14	14	98	18.5	C
	R	24	25	103	7.9	A
	Subtotal	38	39	103	11.7	B
EB	T	617	624	101	2.2	A
	R	21	20	94	1.6	A
	Subtotal	638	644	101	2.2	A
WB	L	17	15	87	4.5	A
	T	607	613	101	0.8	A
	Subtotal	624	628	101	0.9	A
Total		1,301	1,311	101	1.9	A

SimTraffic LOS Report

Project: Midway - The Village TIS
Analysis Period: Existing (2021) Plus Project
Time Period: Evening Peak Hour **Project #: UT21-1835**

Intersection: 580 East & Main Street
Type: Unsignalized

Approach	Movement	Demand Volume	Volume Served		Delay/Veh (sec)	
			Avg	%	Avg	LOS
NB	L	8	7	88	14.6	B
	R	10	9	90	5.9	A
	Subtotal	18	16	89	9.7	A
SB	L	42	40	96	18.2	C
	R	38	36	95	8.2	A
	Subtotal	80	76	95	13.5	B
EB	L	36	36	99	4.5	A
	T	545	546	100	0.8	A
	R	8	10	125	0.4	A
	Subtotal	589	592	101	1.0	A
WB	L	11	10	91	4.8	A
	T	573	585	102	0.9	A
	R	63	61	97	0.4	A
	Subtotal	647	656	101	0.9	A
Total		1,334	1,340	100	1.8	A

Intersection: Main Street & 670 East
Type: Unsignalized

Approach	Movement	Demand Volume	Volume Served		Delay/Veh (sec)	
			Avg	%	Avg	LOS
SB	L	14	12	84	14.1	B
	R	9	9	100	5.9	A
	Subtotal	23	21	91	10.6	B
EB	L	13	14	106	5.0	A
	T	584	582	100	0.8	A
	Subtotal	597	596	100	0.9	A
WB	T	634	643	101	1.5	A
	R	10	10	100	1.1	A
	Subtotal	644	653	101	1.5	A
Total		1,265	1,270	100	1.4	A

SimTraffic LOS Report

Project: Midway - The Village TIS
Analysis Period: Existing (2021) Plus Project
Time Period: Evening Peak Hour **Project #: UT21-1835**

Intersection: Main Street & Access 1
Type: Unsignalized

Approach	Movement	Demand Volume	Volume Served		Delay/Veh (sec)	
			Avg	%	Avg	LOS
SB	<i>L</i>	22	21	94	19.5	C
	<i>R</i>	35	38	108	8.4	A
	Subtotal	57	59	104	12.4	<i>B</i>
EB	<i>L</i>	67	67	100	5.3	A
	<i>T</i>	568	574	101	0.4	A
	Subtotal	635	641	101	0.9	A
WB	<i>T</i>	589	591	100	1.3	A
	<i>R</i>	27	33	121	0.5	A
	Subtotal	616	624	101	1.3	A
Total		1,309	1,324	101	1.6	A

Intersection: River Road & Access 3
Type: Unsignalized

Approach	Movement	Demand Volume	Volume Served		Delay/Veh (sec)	
			Avg	%	Avg	LOS
NB	<i>T</i>	261	261	100	0.9	A
	<i>R</i>	5	5	100	0.8	A
	Subtotal	266	266	100	0.9	A
SB	<i>L</i>	28	29	103	2.7	A
	<i>T</i>	289	285	99	0.4	A
	Subtotal	317	314	99	0.6	A
WB	<i>L</i>	3	2	67	8.0	A
	<i>R</i>	20	20	99	3.7	A
	Subtotal	23	22	96	4.1	A
Total		606	602	99	0.9	A

APPENDIX C

Site Plan



AREA
 TOTAL PROJECT AREA 27.47 ACRES
 R.O.W. DEDICATION ON MAIN 0.18 ACRES

BUILDING CALCULATIONS

	PAD AREA (SF)	%
COMMERCIAL	48,592	37%
RESIDENTIAL	81,401	63%
TOTAL	129,993	100%

GROSS BUILDING AREA

	Area (SF)	%
COMMERCIAL	83,184	26%
RESIDENTIAL (TOTAL)	242,731	74%
RESIDENTIAL 2 STORY	162,822	
RESIDENTIAL ABOVE GARAGE	79,909	
TOTAL GROSS BUILDING	325,915	100%

COMMERCIAL PARKING
 TOTAL PARKING SPACES 189 SPACES

PARKING CALCULATIONS:
 TOTAL GROSS COMMERCIAL 83,184 SF
 NET USEABLE COMMERCIAL AREA WITHOUT POOL PER ARCHITECT 48,198 SF

PARKING RATIO = $\frac{48,198 \text{ SF}}{189 \text{ SPACES}} = 1 \text{ SPACE FOR } 255 \text{ SF}$

NOTES:
 • THE FINAL NUMBER OF REQUIRED SPACES WILL DEPEND ON THE BUILDING TENANT, USE AND FINAL BUILDING DESIGN.

RESIDENTIAL PARKING NOTES:
 • EACH RESIDENTIAL UNIT HAS A 2 CAR GARAGE. THERE ARE ALSO 72 OUTDOOR PARKING SPACES IN THE RESIDENTIAL AREA.
 • PLAN HAS A TOTAL OF 358 PARKING SPACES.

PARKING CALCULATIONS

TOTAL UNITS	143
3 BEDROOMS	143x2.5 = 358 SPACES (REQUIRED)

PARKING SPACES PROVIDED

GARAGES	143x2 = 286
ON SITE PARKING	72
TOTAL	358 SPACES (PROVIDED)

- LEGEND**
- NON-BUILDABLE AREA (25%+ SLOPES)
 - COMMERCIAL BUILDINGS
 - RESIDENTIAL UNIT
 - RESIDENTIAL GARAGES
 - LANDSCAPE AREA

REVISION NOTE - 21 OCT 2021:
 REVISED TO ADD RESIDENTIAL PARKING FOR 3 BEDROOM UNITS. ALSO SEE PARKING TABLE

REVISION NOTE - 29 OCT 2021:
 COMMERCIAL BUILDINGS PAD, GROSS AND NET USEABLE SQUARE FOOTAGES HAVE BEEN UPDATED BY ARCHITECT.

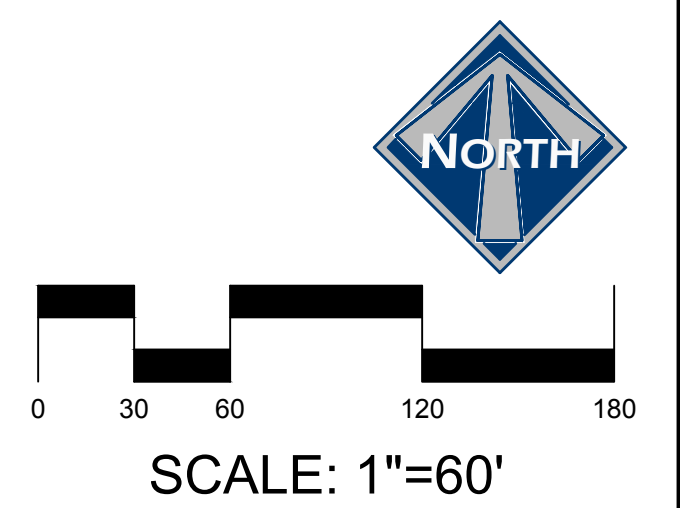

CLUSTER
 THE VILLAGE
 REVISED MASTER PLAN



DESIGN BY: PDB DATE: 4 OCT 2021
 DRAWN BY: DEJ REV: 29 OCT 2021

SHEET
 3

This document is the property of BERG ENGINEERING. It is not to be used for any other project without the written consent of BERG ENGINEERING. The date of this document is 29 OCT 2021.

APPENDIX D

95th Percentile Queue Length Reports

SimTraffic Queueing Report

Project: Midway - The Village TIS

Analysis: Existing (2021) Background

Time Period: Evening Peak Hour

95th Percentile Queue Length (feet)



Project #: UT21-1835

Intersection	NB		SB			EB		WB		
	LR	LTR	LR	LT	R	LT	LTR	LT	LTR	TR
01: River Road & Main Street	--	43	--	190	107	--	125	--	38	--
02: Fox Den Road & Main Street	46	--	--	--	--	--	--	27	--	--
03: 580 East & Main Street	43	--	--	--	--	--	--	39	--	--
04: Main Street & 670 East	--	--	44	--	--	43	--	--	--	2

SimTraffic Queueing Report

Project: Midway - The Village TIS

Analysis: Mitigated Existing (2021) Background

Time Period: Evening Peak Hour

95th Percentile Queue Length (feet)



Project #: UT21-1835

Intersection	NB			SB			EB				WB			
	L	LR	TR	L	LR	TR	L	LT	R	T	L	LT	R	T
01: River Road & Main Street	13	--	26	92	--	67	85	--	8	137	22	--	80	152
02: Fox Den Road & Main Street	--	46	--	--	--	--	--	--	--	--	--	38	--	--
03: 580 East & Main Street	--	43	--	--	--	--	--	--	--	--	--	40	--	--
04: Main Street & 670 East	--	--	--	--	43	--	--	40	--	--	--	--	--	--

SimTraffic Queueing Report

Project: Midway - The Village TIS

Analysis: Existing (2021) Plus Project

Time Period: Evening Peak Hour

95th Percentile Queue Length (feet)



Project #: UT21-1835

Intersection	NB				SB					EB					WB					
	L	LR	LTR	TR	L	LR	LT	LTR	TR	L	LT	R	T	TR	L	LR	LT	R	T	TR
01: River Road & Main Street	12	--	--	28	94	--	--	--	76	90	--	8	164	--	21	--	--	68	150	--
02: Fox Den Road & Main Street	--	55	--	--	--	--	--	--	--	--	--	--	--	--	--	--	66	--	--	--
03: 580 East & Main Street	--	--	41	--	--	--	--	60	--	41	--	--	--	2	--	--	45	2	--	--
04: Main Street & 670 East	--	--	--	--	--	44	--	--	--	--	52	--	--	--	--	--	--	--	--	--
05: Main Street & Access 1	--	--	--	--	--	70	--	--	--	56	--	--	--	--	--	--	--	--	--	12
06: River Road & Access 3	--	--	--	--	--	--	38	--	--	--	--	--	--	--	--	42	--	--	--	--

APPENDIX 3 – FUNDRAISING

Fundraising Plan

1. We have a financial team with deep experience and a track record of success in raising and managing funds of this scale and greater.
2. Construction will not begin until all funds are committed in writing and are legally binding.
3. The funding will include ongoing commitments from Midway residents who are enthusiastic MAC supporters.



FUNDING THE MAC

The Fundraising Team:

Matt Waldrip - Managing partner of Dauntless Capital Partners. The group has raised over \$800m in equity and over \$1.5 billion in assets under management since March, 2021. Served as Chief of Staff to Senator Mitt Romney. Managed Romney's successful Utah campaign. Previously, head of network development for Solamere Capital. Executive Director of the E2 Summit, an exclusive annual gathering of world leaders in politics, industry, and media. Senior Finance Advisor to former Speaker of the House Paul D. Ryan and Deputy National Finance Director for Mitt Romney's 2012 campaign for president. BA from BYU. He will oversee fundraising for the MAC .

Brent Lange - Brent Lange, Manager, RaiseGood, LLC. Impact funding capital advisor and former V.P., Chief Administrative Officer, Treasurer and principal fundraiser for Hale Center Theater in Sandy. Brent first showcased his talents with the Utah Symphony, energizing the non-profit's fundraising programs with significant support from the community and private organizations. His passion for the arts continued in a lead role for Hale Centre Theatre. During his executive tenure, the theatre dramatically increased its facilities, budget, and number of patrons, becoming the sixth most-attended theatre in the world. Brent is currently serving as Chief Development Officer at Thanksgiving Point. Brent will assist as financial and organizational advisor.

Jeff Strong – Outstanding career history as a senior executive with such industry leaders as Procter & Gamble, Johnson & Johnson and Sun Products. Following his successful business experience, he has continued to provide leadership as a business consultant and private equity advisor. Most recently, he has helped educate a new generation of business entrepreneurs as the director of the marketing lab at the BYU Marriott School of Business. He is a key business and financial advisor to the Midway Arts Center Foundation. Jeff lives in Midway.

Randon Wilson - Successful career with prominent legal firms in Utah. In addition to his leadership in land use, agricultural, banking, business and corporate law, he has been a director of several prominent organizations in the legal and business world and a leader in his firms' organizations. Among his many community services, he has served as the chair of the This is the Place Foundation and the Midway Heritage Foundation. He has played a prominent role in the development of Midway and was recognized with his wife Gayle as Honored Citizens in 2014. He has been an important member of the Midway Arts Center Foundation since its inception.

Local Fundraisers/Donors – Twenty to twenty-five local, philanthropic supporters of the arts who will not only aid in procuring donations but will provide ongoing, local support for the continued operation of The MAC.

Graystone Strategies – Graystone Strategies is a comprehensive growth accelerator for businesses and non-profits. The company also provides donor research and communications, fundraising training, website development, assessment and growth strategies, digital fundraising, and provides donor presentations collateral.

Stuart Waldrip - Former business trial lawyer and Superior Court judge, currently specializing in mediation and arbitration. He has served as general counsel for several different companies in the hospitality, health care, entertainment and development industries, taught law at BYU and has presented at a number of continuing education courses in his field. He will manage financing and building the Arts Center. He has been with HVAF and the MAC since their inception.

THE PROJECT:

Construction cost – 45,000 sf @ \$750/sf = ± \$33,750,000

Architectural/Engineering/Sound/Light Consultants = 10% or \$3,375,000

Land cost 1.6 acres = \$2.9 million

Endowment fund - \$4 million – to provide approximately \$200,000 each year for facility upkeep and to lower rental costs for local arts groups

TOTAL: - \$44,025,000 or approximately \$45,000,000

THE PLAN:

Foundations and Institutions - \$35,000,000

Individuals - \$10,000,000

WHEN WILL IT BEGIN?

Immediately, once Midway City indicates general concept support for the project and general support for a C2 Zone text amendment to allow this project to proceed.

APPENDIX 4 – FINANCIAL PROJECTIONS

**Midway Arts Center/High Valley Arts
Financial Projections - Year 1 - 4 Adult Shows, 3 Youth Shows**

REVENUE				NOTES:
Ticket Sales				
Adult Shows	Adult	\$	532,812	<i>Assumptions based on past experience</i>
Children Shows	Child	\$	97,290	<i>Assumptions based on past experience</i>
Youth Program Revenue		\$	91,500	<i>Assumptions based on past experience + Hale Theater Orem</i>
Sponsorships/Grants		\$	40,000	<i>Assumptions based on past experience</i>
Endowment Income		\$	200,000	<i>Assuming 5% ROI (when obtain endowment)</i>
Corporate Sponsors		\$	42,000	<i>Assumptions based on Hale Theater West Valley</i>
Annual Fundraiser		\$	40,000	<i>Assumptions based on past experience</i>
Rent Income		\$	30,000	<i>Assumptions based on theater industry standard</i>
Miscellaneous Donations		\$	20,000	<i>Assumptions based on past experience</i>
Concessions		\$	17,820	<i>Assumptions based on past experience</i>
Other		\$	7,000	<i>Random checks & In-kind that come in from past experience</i>
			\$ 1,118,422	
EXPENSES				
Event Expenses		\$	98,806	<i>Assumptions based on past experience</i>
Other Production Expense		\$	342,398	<i>Assumptions based on past experience</i>
Administration Expense		\$	101,164	<i>Assumptions based on past experience + Centerpoint Theater</i>
Concession Expense		\$	10,200	<i>Assumptions based on past experience</i>
Development Expenses		\$	60,000	<i>Assumptions based on Centerpoint Theater</i>
Facility Expense		\$	183,800	<i>Assumptions based on Centerpoint Theater</i>
Marketing Expense		\$	75,000	<i>Assumptions based on Centerpoint Theater</i>
			\$ 871,368	
NET INCOME <EXPENSES>		\$	247,054	

**Midway Arts Center/High Valley Arts
Financial Projections - Year 3 - 6 Adult Shows, 4 Youth Shows**

REVENUE				NOTES:
Ticket Sales				
Adult Shows	Adult	\$	1,329,720	<i>Assumptions based on past experience</i>
Children Shows	Child	\$	156,600	<i>Assumptions based on past experience</i>
Youth Program Revenue		\$	124,400	<i>Assumptions based on past experience + Hale Theater Orem</i>
Sponsorships/Grants		\$	60,000	<i>Assumptions based on past experience</i>
Endowment Income		\$	200,000	<i>Assuming 5% ROI (when obtain endowment)</i>
Corporate Sponsors		\$	70,000	<i>Assumptions based on Hale Theater West Valley</i>
Annual Fundraiser		\$	50,000	<i>Assumptions based on past experience</i>
Rent Income		\$	45,000	<i>Assumptions based on theater industry standard</i>
Miscellaneous Donations		\$	30,000	<i>Assumptions based on past experience</i>
Concessions		\$	33,840	<i>Assumptions based on past experience</i>
Other		\$	7,000	<i>Random checks & In-kind that come in from past experience</i>
			\$ 2,106,560	
EXPENSES				
Event Expenses		\$	190,800	<i>Assumptions based on past experience</i>
Other Production Expense		\$	556,976	<i>Assumptions based on past experience</i>
Administration Expense		\$	129,571	<i>Assumptions based on past experience + Centerpoint Theater</i>
Concession Expense		\$	21,120	<i>Assumptions based on past experience</i>
Development Expenses		\$	84,000	<i>Assumptions based on Centerpoint Theater</i>
Facility Expense		\$	202,180	<i>Assumptions based on Centerpoint Theater</i>
Marketing Expense		\$	110,000	<i>Assumptions based on Centerpoint Theater</i>
			\$ 1,294,647	
NET INCOME <EXPENSES>			\$ 811,913	

**Midway Arts Center/High Valley Arts
Financial Projections - Year 5 - 6 Adult Shows, 4 Youth Shows**

REVENUE				NOTES:
Ticket Sales				
Adult Shows	Adult	\$ 1,564,920		<i>Assumptions based on past experience</i>
Children Shows	Child	\$ 319,680		<i>Assumptions based on past experience</i>
Youth Program Revenue		\$ 176,400		<i>Assumptions based on past experience + Hale Theater Orem</i>
Sponsorships/Grants		\$ 90,000		<i>Assumptions based on past experience</i>
Endowment Income		\$ 200,000		<i>Assuming 5% ROI (when obtain endowment)</i>
Corporate Sponsors		\$ 98,000		<i>Assumptions based on Hale Theater West Valley</i>
Annual Fundraiser		\$ 60,000		<i>Assumptions based on past experience</i>
Rent Income		\$ 60,000		<i>Assumptions based on theater industry standard</i>
Miscellaneous Donations		\$ 40,000		<i>Assumptions based on past experience</i>
Concessions		\$ 36,720		<i>Assumptions based on past experience</i>
Other		\$ 7,000		<i>Random checks & In-kind that come in from past experience</i>
		\$ 2,652,720		
EXPENSES				
Event Expenses		\$ 221,520		<i>Assumptions based on past experience</i>
Other Production Expense		\$ 589,468		<i>Assumptions based on past experience</i>
Administration Expense		\$ 153,215		<i>Assumptions based on past experience + Centerpoint Theater</i>
Concession Expense		\$ 25,555		<i>Assumptions based on past experience</i>
Development Expenses		\$ 108,400		<i>Assumptions based on Centerpoint Theater</i>
Facility Expense		\$ 222,398		<i>Assumptions based on Centerpoint Theater</i>
Marketing Expense		\$ 150,000		<i>Assumptions based on Centerpoint Theater</i>
		\$ 1,470,556		
NET INCOME <EXPENSES>		\$ 1,182,164		

APPENDIX 5 – GEOTECHNICAL REPORT



GEOTECHNICAL ENGINEERING STUDY

Midway Arts Center

330-368 East Main Street
Midway, Utah

CMT PROJECT NO. 18372

FOR:
High Valley Arts Foundation
817 Double Eagle Drive
Midway, Utah 84049

May 6, 2022

ENGINEERING • GEOTECHNICAL • ENVIRONMENTAL (ESA I & II) •
MATERIALS TESTING • SPECIAL INSPECTIONS •
ORGANIC CHEMISTRY • PAVEMENT
DESIGN • GEOLOGY

CMT TECHNICAL SERVICES

May 6, 2022

Mr. Stuart Waldrip
High Valley Arts Foundation
817 Double Eagle Drive
Midway, Utah 84049

Subject: Geotechnical Engineering Study
Midway Arts Center
330-369 East Main Street
Midway, Utah
CMT Project No. 18372

Mr. Waldrip:

Submitted herewith is the report of our geotechnical engineering study for the subject site. This report contains the results of our findings and an engineering interpretation of the results with respect to the available project characteristics. It also contains recommendations to aid in the design and construction of the earth related phases of this project.

On April 28, 2022, a CMT Technical Services (CMT) staff professional was on-site and supervised the excavation of 4 test pits extending to depths of about 1.5 to 3.0 feet below the existing ground surface where excavator refusal occurred on bedrock. We obtained samples of the soils overlying the bedrock during the field operations that we subsequently transported to our laboratory for further testing and observation.

Conventional spread and/or continuous footings may be utilized to support the proposed structure, provided the recommendations in this report are followed. This report presents detailed discussions of design and construction criteria for this site.

We appreciate the opportunity to work with you at this stage of the project. CMT offers a full range of Geotechnical Engineering, Geological, Material Testing, Special Inspection services, and Phase I and II Environmental Site Assessments. With offices throughout Utah, Idaho, Arizona, Colorado and Texas, our staff is capable of efficiently serving your project needs. If we can be of further assistance or if you have any questions regarding this project, please do not hesitate to contact us at 801-492-4132.

Sincerely,
CMT Engineering Laboratories

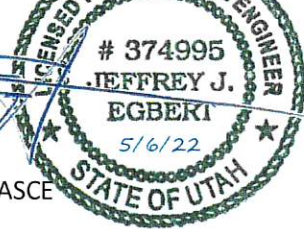
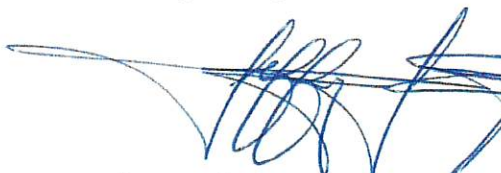

Jeffrey J. Egbert, P.E., LEED A.P., M. ASCE
Senior Geotechnical Engineer

Reviewed by:



William G. Turner, P.E., M. ASCE
Senior Geotechnical Engineer

TABLE OF CONTENTS

1.0 INTRODUCTION	1
1.1 General	1
1.2 Objectives, Scope and Authorization	1
1.3 Description of Proposed Construction	2
1.4 Executive Summary	2
2.0 FIELD EXPLORATION	3
2.1 General	3
2.2 Infiltration Testing	3
3.0 LABORATORY TESTING	4
4.0 GEOLOGIC & SEISMIC CONDITIONS	4
4.1 Geologic Setting.....	4
4.2 Faulting	5
4.3 Seismicity.....	6
4.3.1 Site Class	6
4.3.2 Ground Motions.....	6
4.3.3 Liquefaction	7
4.4 Other Geologic Hazards.....	7
5.0 SITE CONDITIONS	8
5.1 Surface Conditions.....	8
5.2 Subsurface Soils	8
5.3 Groundwater	8
5.4 Site Subsurface Variations.....	8
6.0 SITE PREPARATION AND GRADING	9
6.1 General	9
6.2 Temporary Excavations	9
6.3 Fill Material.....	10
6.4 Fill Placement and Compaction.....	10
6.5 Utility Trenches.....	11
6.6 Stabilization	12
7.0 FOUNDATION RECOMMENDATIONS	12
7.1 Foundation Recommendations	12
7.2 Installation.....	13
7.3 Estimated Settlement.....	13
7.4 Lateral Resistance.....	13
8.0 LATERAL EARTH PRESSURES	14
9.0 FLOOR SLABS	14
10.0 DRAINAGE RECOMMENDATIONS	15
11.0 PAVEMENTS	15
12.0 QUALITY CONTROL	16
12.1 Field Observations	16
12.2 Fill Compaction.....	16
12.3 Excavations.....	17
13.0 LIMITATIONS	17
APPENDIX	
Figure 1: Site Plan	
Figures 2-5: Test Pit Logs	
Figure 6: Key to Symbols	

1.0 INTRODUCTION

1.1 General

CMT Technical Services (CMT) was retained to conduct a geotechnical subsurface study for the proposed construction of a performing arts center. The site consists of two existing residential lots located on the south side of Main Street and 330 and 368 East in Midway, Utah, as shown in the **Vicinity Map** below.

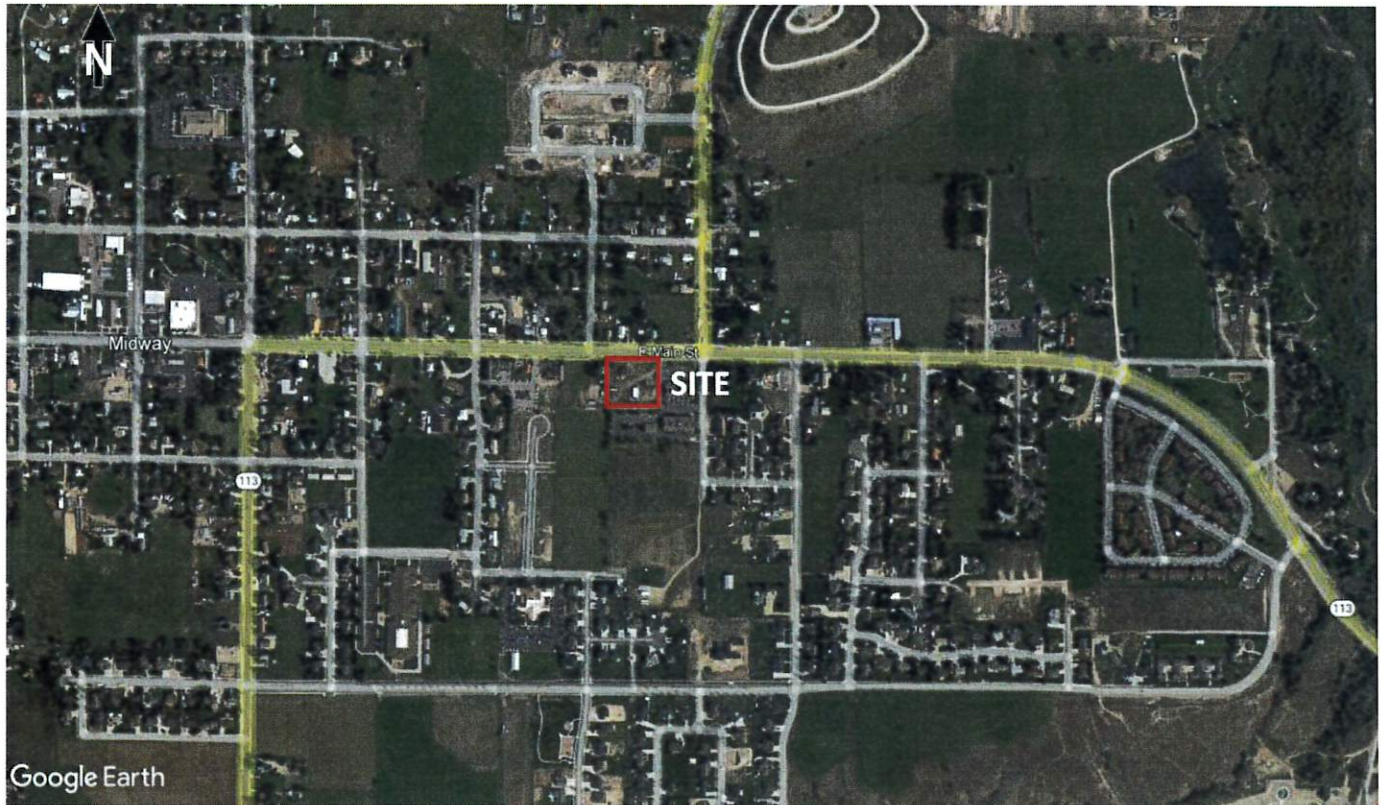

VICINITY MAP

1.2 Objectives, Scope and Authorization

The objectives and scope of our study were planned in discussions between Mr. Michael Johnston of Summit Engineering Group, Inc., and Mr. Jeff Egbert of CMT. In general, the objectives of this study were to define and evaluate the subsurface soil and groundwater conditions at the site, and provide appropriate foundation, earthwork, pavement and seismic recommendations to be utilized in the design and construction of the proposed development.

In accomplishing these objectives, our scope of work included performing field exploration, which consisted of the excavating/logging/sampling of 4 test pits, performing laboratory testing on representative samples of the subsurface soils collected in the test pits, and conducting an office program, which consisted of correlating

available data, performing engineering analyses, and preparing this summary report. This scope of work was authorized by returning a signed copy of our proposal dated and executed on April 22, 2022.

1.3 Description of Proposed Construction

We understand that the proposed structure will be a two story performing arts center which we project will be of conventional wood frame or light steel frame construction supported on concrete footings with a floor slab established at or near the existing site grade. We project that maximum structural loads for the center will be on the order of 8,000 pounds per lineal foot for walls, 100,000 pounds for columns, and relatively light floor slab loads having an average uniform loading not exceeding 100 pounds per square foot. If the structural loading conditions are different than we have projected, please notify us so that any appropriate modifications to our conclusions and recommendations contained herein can be made.

We also understand that pavements at the site will include light-duty parking areas which we anticipate will utilize asphalt surfacing. Traffic is projected to consist of mostly automobiles and light trucks, a few medium-weight delivery trucks, a weekly garbage truck, and an occasional fire truck.

Site development will require removal of existing structures and some earthwork in the form of minor cutting and filling. A site grading plan was not available at the time of this report, but we project that maximum cuts and fills may be on the order of 2 to 3 feet. If deeper cuts or fills are planned, CMT should be notified to provide additional recommendations, if needed.

1.4 Executive Summary

The proposed structure can be supported upon conventional spread and continuous wall foundations. The most significant geotechnical aspects regarding site development include the following:

1. Approximately 6 inches of topsoil on the surface, which will require removal beneath the structure and pavements;
2. Near surface soils consist of CLAY (CL) and SAND (SC-SM) extending about 1.5 to 2.0 below the existing site grade where bedrock was encountered, and upon which excavator refusal occurred at 1.5 to 3.0 feet below the surface;
3. Groundwater was not encountered within the depths explored; and
4. Foundations and floor slabs may be placed on entirely on suitable, undisturbed natural soils, entirely on structural fill extending to suitable, undisturbed natural soils or bedrock, or entirely on competent bedrock.

CMT must assess that topsoil, undocumented fills (if encountered), debris, disturbed or unsuitable soils have been removed and that suitable soils have been encountered prior to placing site grading fills, footings, slabs, and pavements.

In the following sections, detailed discussions pertaining to the site are provided, including subsurface descriptions, geologic/seismic setting, earthwork, foundations, lateral resistance, lateral pressure, floor slabs, and pavements.

2.0 FIELD EXPLORATION

2.1 General

In order to define and evaluate the subsurface soil and groundwater conditions, 4 test pits were excavated with a backhoe at the site to depths of approximately 1.5 to 3.0 feet below the existing ground surface where excavator refusal occurred on bedrock (tufa). Locations of the test pits are shown on **Figure 1, Site Plan**, included in the Appendix. The field exploration was performed under the supervision of an experienced member of our geotechnical staff.

Representative samples of the soils overlying the bedrock were collected by obtaining disturbed "grab" samples from within each test pit. The samples were sealed in plastic bags prior to transport to the laboratory.

The subsurface soils encountered in the test pits were classified in the field based upon visual and textural examination, logged and described in general accordance with ASTM¹ D-2488. These field classifications were supplemented by subsequent examination and testing of select samples in our laboratory. Graphical representations of the subsurface conditions encountered are presented on each individual Test Pit Log, **Figures 2 through 5**, included in the Appendix. A Key to Symbols defining the terms and symbols used on the logs, is provided as **Figure 6** in the Appendix.

Upon completion of logging and sampling, the test pits were backfilled with the excavated soils. When backfilling, minimal to no effort was made to compact the backfill and no compaction testing was performed. Thus, the test pit backfill is considered undocumented fill and settlement of the backfill in the test pits over time should be anticipated.

2.2 Infiltration Testing

We also performed infiltration testing as part of our field exploration within test pit TP-3 at a depth of about 1 foot below the existing ground surface. The testing consisted of creating and filling a small hole at that depth with water, and measuring the rate of water drop within the small hole over a certain time period. We repeated this process multiple times. The results of this test indicate that the silty sand soils at this site have an infiltration rate of approximately 2 minutes per inch. This rate could increase (become slower) over time due to siltation, thus we recommend an appropriate factor of safety be applied for design.

However, with the shallow bedrock, using sumps for collecting and discharging of runoff water into the underlying soils is likely not practical, unless deep sumps/wells are drilled.

¹American Society for Testing and Materials

3.0 LABORATORY TESTING

Selected samples of the subsurface soils were subjected to various laboratory tests to assess pertinent engineering properties, as follows:

1. Moisture Content, ASTM D-2216, Percent moisture representative of field conditions
2. Atterberg Limits, ASTM D-4318, Plasticity and workability
3. Gradation Analysis, ASTM D-1140/C-117, Grain Size Analysis

Laboratory test results are presented on the test pit logs (**Figures 2 through 5**) and in the following **Lab Summary Table**:

LAB SUMMARY TABLE

TEST PIT	DEPTH (feet)	SOIL CLASS	SAMPLE TYPE	MOISTURE CONTENT(%)	GRADATION			ATTERBERG LIMITS		
					GRAV.	SAND	FINES	LL	PL	PI
TP-1	1	CL	Grab	7				33	21	12
TP-3	1.5	SC-SM	Grab	18			39			
TP-4	1	SC-SM	Grab	11			14			

4.0 GEOLOGIC & SEISMIC CONDITIONS

4.1 Geologic Setting

The subject site is located in the west-central portion of the Heber Valley, part of the Wasatch Hinterlands Section of the Middle Rocky Mountain Physiographic Province of north-central Utah. The Wasatch Hinterlands are described by Stokes² as “a belt of mixed, moderately rugged topography” located between the Wasatch Mountains to the west and the Uinta Mountains to the east. Stokes further describes the area as having “varied and unorganized topography with hilly areas dominating valley areas.” The site sits at an elevation of between approximately 5,574 and 5,571 feet above sea level with lower elevation towards the south. The Heber Valley is believed to have been formed by late Tertiary normal faulting associated with Miocene to recent extension of the Basin and Range Physiographic Province to the west. These valley-forming faults are now considered to be inactive (no evidence of movement during the past 10,000, years). During Quaternary time the valley has been subject to both erosional and depositional processes associated with the Provo River and its tributaries. During Quaternary time, the Midway area, including the location of the target property has also been impacted by hydrothermal spring activity. These spring waters have deposited layers of carbonate rock called tufa throughout much of the northwest portion of Heber Valley in the Midway area.

²Stokes, W.L., 1986, *Geology of Utah*; Utah Museum of Natural History, University of Utah, and Utah Geological and Mineral Survey, Department of Natural Resources, p. 243

The geology of USGS Heber City, Utah 7.5 Minute Quadrangle, which includes the location of the subject site, has been mapped by Biek³. The surficial geology at the subject site is mapped as “Middle fan alluvium over calcareous spring tufa deposit” (Map Unit Qaf₂/Qst) dated Holocene to upper Pleistocene. Unit Qaf₂/Qst is described in the referenced map as “Middle fan alluvium that forms a veneer over and interfingers with calcareous spring tufa deposits in the Midway area; forms a surface of slightly lower elevation with fewer tufa exposures than adjacent Qafo/Qst deposits; tufa is pale grayish yellow, weathers light brown, and is highly porous and vuggy; tufa is exposed at and near mapped springs and likely underlies much of the surrounding surface where it is concealed by and interbedded with fan alluvium; tufa, interbedded with basin-fill sediments, is reported to depths of nearly 170 feet (52 m) in monitoring wells (Wallace, 2005) and to 392 feet (120 m) in a water well (Mayo and others, 2005) near the Midway fish hatchery immediately south of the map area.” Refer to the **Geologic Map**, shown below.

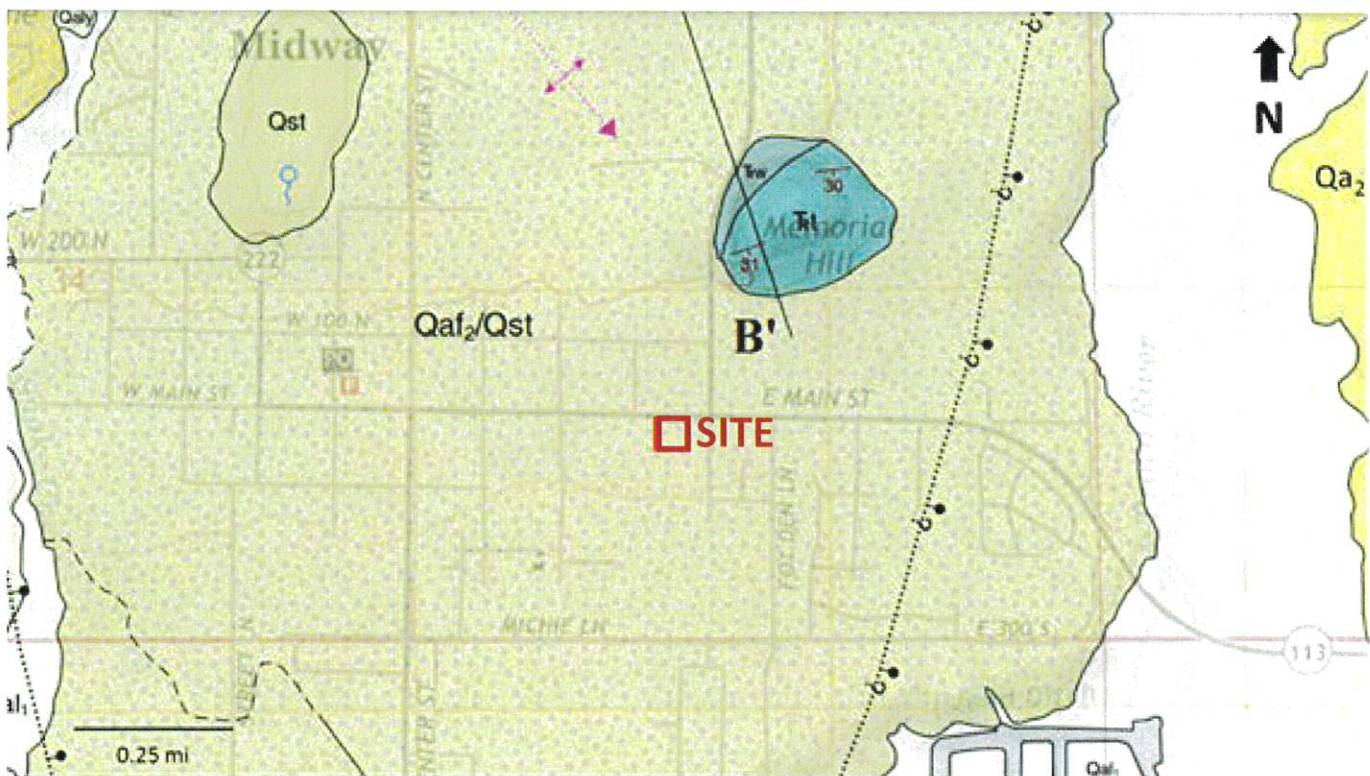

GEOLOGIC MAP

4.2 Faulting

No active surface fault rupture traces are mapped crossing, adjacent to, or projecting toward the site on the referenced geologic map. The nearest mapped active fault is the Provo section of the Wasatch Fault Zone approximately 15.5 miles west of the site⁴.

³ Robert F. Biek, 2019, Interim Geologic Map of the Heber City Quadrangle, Summit and Wasatch Counties, Utah. OFR-712dm. UGS. 1:24,000 scale.

⁴ Utah Quaternary Fault & Fold Map, Utah Geologic Survey: <https://geology.utah.gov/apps/qfaults/>

4.3 Seismicity

4.3.1 Site Class

Utah has adopted the International Building Code (IBC) 2018, which determines the seismic hazard for a site based upon 2014 mapping of bedrock accelerations prepared by the United States Geologic Survey (USGS) and the soil site class. The USGS values are presented on maps incorporated into the IBC code and are also available based on latitude and longitude coordinates (grid points). For site class definitions, IBC 2018 Section 1613.2.2 refers to Chapter 20, Site Classification Procedure for Seismic Design, of ASCE⁵ 7-16, which stipulates that the average values of shear wave velocity, blow count and/or shear strength within the upper 100 feet (30 meters) be utilized to determine seismic site class.

Considering our explorations only extended to a maximum depth of about 3 feet and that shallow bedrock was encountered, it is our opinion the site best fits Site Class B – Rock Profile (estimated), which we recommend for seismic structural design.

4.3.2 Ground Motions

The 2014 USGS mapping utilized by the IBC provides values of peak ground, short period and long period spectral accelerations for the Site Class B/C boundary and the Risk-Targeted Maximum Considered Earthquake (MCE_R). This Site Class B/C boundary represents average bedrock values for the Western United States and must be corrected for local soil conditions. The table and response spectra on the following page summarizes the peak ground, short period and long period accelerations for the MCE_R event, and incorporates appropriate soil correction factors for a Site Class B (estimated) soil profile at site grid coordinates of 40.5116 degrees north latitude and -111.4651 degrees west longitude:

⁵American Society of Civil Engineers

SPECTRAL ACCELERATION PERIOD, T	SITE CLASS B/C BOUNDARY [mapped values] (g)	SITE COEFFICIENT	SITE CLASS B* [adjusted for site class effects] (g)	MULTIPLIER	DESIGN VALUES (g)
Peak Ground Acceleration	PGA = 0.258	$F_{pga} = 1.000$	$PGA_M = 0.258$	1.000	$PGA_M = 0.258$
0.2 Seconds (Long Period Acceleration)	$S_S = \mathbf{0.585}$	$F_a = 1.000$	$S_{MS} = 0.585$	0.667	$S_{DS} = 0.390$
	(no exceptions needed)	$F_a = (N/A)$	$S_{MS} = (N/A)$	0.667	$S_{DS} = (N/A)$
1.0 Second (Long Period Acceleration)	$S_1 = \mathbf{0.208}$	$F_v = 1.000$	$S_{M1} = 0.208$	0.667	$S_{D1} = 0.139$
	(no exceptions needed)	$F_v = (N/A)$	$S_{M1} = (N/A)$	0.667	$S_{D1} = (N/A)$

NOTES: 1. TL (seconds): **8** * Site Class B Without Measurements
 2. Site Class: **B** **4. No Exceptions Needed**
 3. Have data to verify? **no**

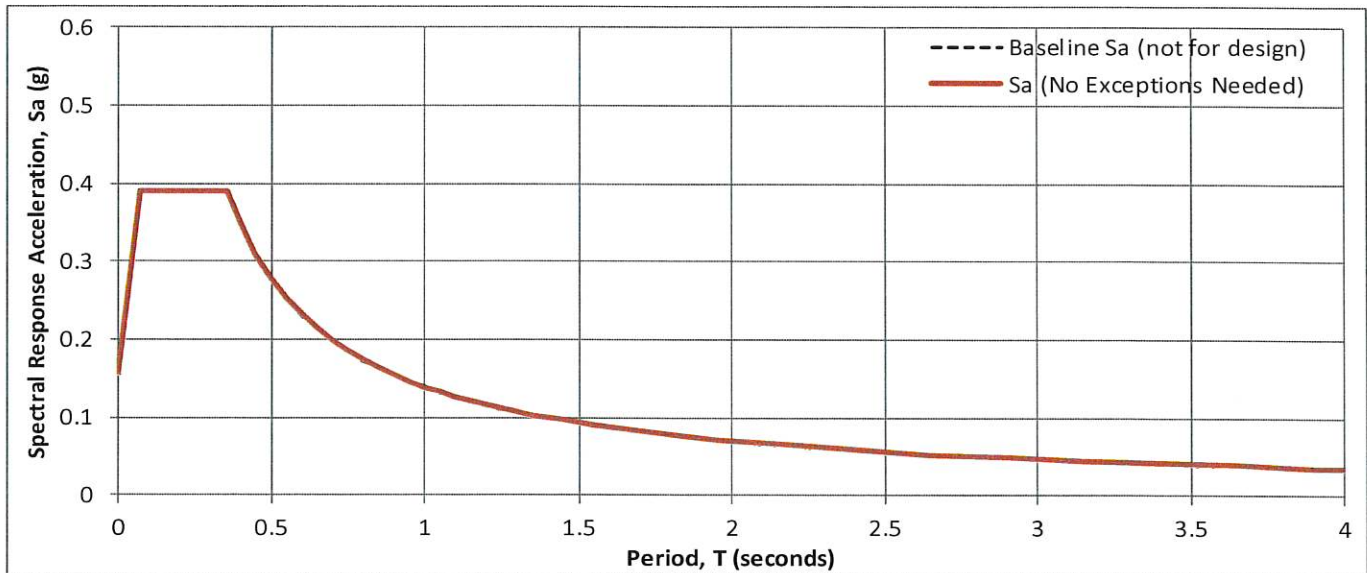

4.3.3 Liquefaction

Liquefaction is defined as the condition when saturated, loose, sandy soils lose their support capabilities because of excessive pore water pressure which develops during a seismic event. Clayey soils, even if saturated, will generally not liquefy during a major seismic event.

A special liquefaction study was not performed for this site. We encountered unsaturated, clay and clayey sand overlying shallow bedrock. In our opinion, the soils we encountered have a very low liquefaction potential.

4.4 Other Geologic Hazards

No landslide deposits or features, including lateral spread deposits, are mapped on or adjacent to the site. The site is not located within a known or mapped debris flow, stream flooding⁶, or rock fall hazard area.

⁶Federal Emergency Management Agency:
<https://msc.fema.gov/portal/search?AddressQuery=400%20East%20Main%20Street%2C%20Midway%2C%20Utah#searchresultsanchor>

5.0 SITE CONDITIONS

5.1 Surface Conditions

At the time the test pits were excavated the site consisted of two adjacent residential lots. The western lot was occupied by an existing single family residence with a shed in the southeast portion of the lot. A small shed occupied the eastern lot. Based upon aerial photos dating back to 1993 that are readily available on the internet, a residence previously occupied the eastern lot and was removed sometime between 2016 and 2017. The photos also indicate several mature trees were present around the existing residence on the western lot, which appear to have been removed between 2019 and 2021. Site grade slopes gently downward to the south. Vegetation consists of grasses and weeds. The site is bordered on the north by Main Street, on the south and east by commercial development, and on the west by a residence (see **Vicinity Map** in **Section 1.1** above).

5.2 Subsurface Soils

At the locations of the test pits we encountered approximately 6 inches of topsoil at the surface. Natural soils observed beneath the topsoil consisted of slightly moist, medium stiff (estimated), brown CLAY (CL) on the north side of the site, grading to slightly moist, medium dense (estimated), brown Silty-Clayey SAND (SC-SM) ,on the south side of the site, extending to depths of 1.5 to 2.0 feet below the existing ground surface where bedrock (tufa) was encountered. We attempted to excavate into the bedrock at the locations of test pits TP-3 and TP-4 and were only able to excavate an additional 6 to 12 inches into the rock before excavator refusal occurred.

For a more descriptive interpretation of subsurface conditions, please refer to the test pit logs, **Figures 2 through 5**, which graphically represent the subsurface conditions encountered. The lines designating the interface between soil types on the logs generally represent approximate boundaries - in situ, the transition between soil types may be gradual.

5.3 Groundwater

We did not encounter groundwater at the time of our field explorations within the maximum depth explored of about 3 feet below the existing ground surface. Therefore, we do not anticipate that groundwater will affect the proposed construction.

Groundwater levels can fluctuate seasonally. Numerous other factors such as heavy precipitation, irrigation of neighboring land, and other unforeseen factors, may also influence ground water elevations at the site. The detailed evaluation of these and other factors, which may be responsible for ground water fluctuations, and the magnitude of potential fluctuations, is beyond the scope of this study.

5.4 Site Subsurface Variations

Based on the results of the subsurface explorations and our experience, variations in the continuity and nature of subsurface conditions should be anticipated. Due to the heterogeneous characteristics of natural soils, care

should be taken in interpolating or extrapolating subsurface conditions between or beyond the exploratory locations.

Also, after completing the logging and sampling, the test pits were backfilled with the excavated soils but minimal to no effort was made to compact these soils. Thus, the test pit backfill is considered undocumented fill and settlement of the backfill in the test pits over time should be anticipated.

6.0 SITE PREPARATION AND GRADING

6.1 General

We understand any existing structures on the site will be razed and removed. We anticipate the existing and previous residences do/did not have a basement. Removal should also include any existing underground utilities that will be abandoned. Resulting excavations should be backfilled with properly compacted structural fill.

All deleterious materials should be stripped from the site prior to commencement of construction activities. This includes vegetation, topsoil, loose and disturbed soils, etc. Based upon the conditions observed in the test pits there is topsoil on the surface of the site which we estimated to be about 6 inches in thickness. When stripping and grubbing, topsoil should be distinguished by the apparent organic content and not solely by color; thus we estimate that topsoil stripping will need to include the upper 4 inches.

Site clearing and grubbing should be observed by a CMT geotechnical engineer to assess that suitable natural soils have been exposed and any deleterious materials, loose and/or disturbed soils have been removed, prior to placing site grading fills, footings, slabs, or pavements.

Fill placed over large areas to raise overall site grades can induce settlements in the underlying natural soils. If more than 3 feet of site grading fill is anticipated over the natural ground surface, we should be notified to assess potential settlements and provide additional recommendations as needed. These recommendations may include placement of the site grading fill far in advance to allow potential settlements to occur prior to construction.

6.2 Temporary Excavations

Groundwater was not encountered within the depths explored, about 1.5 to 3.0 feet at the time of our field explorations, and thus is not anticipated to be encountered in excavations.

In clayey (cohesive) soils, temporary construction excavations not exceeding 4 feet in depth may be constructed with near-vertical side slopes. Temporary excavations up to 8 feet deep, above or below groundwater, may be constructed with side slopes no steeper than one-half horizontal to one vertical (0.5H:1V).

For sandy/gravelly (cohesionless) soils, temporary construction excavations not exceeding 4 feet in depth should be no steeper than one-half horizontal to one vertical (0.5H:1V). For excavations up to 8 feet and above groundwater, side slopes should be no steeper than one horizontal to one vertical (1H:1V). Excavations

encountering saturated cohesionless soils will be very difficult to maintain, and will require very flat side slopes and/or shoring, bracing and dewatering.

All excavations must be inspected periodically by qualified personnel. If any signs of instability or excessive sloughing are noted, immediate remedial action must be initiated. All excavations should be made following OSHA safety guidelines.

6.3 Fill Material

Following are our recommendations for the various fill types we anticipate will be used at this site:

FILL MATERIAL TYPE	DESCRIPTION RECOMMENDED SPECIFICATION
Structural Fill	Placed below structures, flatwork and pavement. Well-graded sand/gravel mixture, with maximum particle size of 4 inches, a minimum 70% passing 3/4-inch sieve, a maximum 20% passing he No. 200 sieve, and a maximum Plasticity Index of 10.
Site Grading Fill	Placed over larger areas to raise the site grade. Sandy to gravelly soil, with a maximum particle size of 6 inches, a minimum 70% passing 3/4-inch sieve, a maximum 50% passing No. 200 sieve, and a maximum Plasticity Index of 15.
Non-Structural Fill	Placed below non-structural areas, such as landscaping. On-site soils or imported soils, with a maximum particle size of 8 inches, including silt/clay soils not containing excessive amounts of degradable/organic material (see discussion below).
Stabilization Fill	Placed to stabilize soft areas prior to placing structural fill and/or site grading fill. Coarse angular gravels and cobbles 1 inch to 8 inches in size. May also use 1.5-inch to 2.0-inch gravel placed on stabilization fabric, such as Mirafi RS280i, or equivalent (see Section 6.6).

On-site sand soils do not appear suitable for use as structural fill, but may be used as site grading fill and non-structural fill.

On-site clay soils are not suitable for use as structural fill, but may be used as site grading fill and non-structural fill. Note that these clay soils are moisture-sensitive, which means they are inherently more difficult to work with in proper moisture conditioning (they are very sensitive to changes in moisture content), requiring very close moisture control during placement and compaction. This will be very difficult, if not impossible, during wet and cold periods of the year. We also recommend the site grading fill thickness using on-site clay soils not exceed a maximum of 3 feet below structures, to minimize potential settlements.

All fill material should be approved by a CMT geotechnical engineer prior to placement.

6.4 Fill Placement and Compaction

The various types of compaction equipment available have their limitations as to the maximum lift thickness that can be compacted. For example, hand operated equipment is limited to lifts of about 4 inches and most “trench compactors” have a maximum, consistent compaction depth of about 6 inches. Large rollers, depending on soil and moisture conditions, can achieve compaction at 8 to 12 inches. The full thickness of each lift should

be compacted to at least the following percentages of the maximum dry density as determined by ASTM D-1557 (or AASHTO⁷ T-180) in accordance with the following recommendations:

LOCATION	TOTAL FILL THICKNESS (FEET)	MINIMUM PERCENTAGE OF MAXIMUM DRY DENSITY
Beneath an area extending at least 4 feet beyond the perimeter of structures, and below flatwork and pavement (applies to structural fill and site grading fill) extending at least 2 feet beyond the perimeter	0 to 5	95
Site grading fill outside area defined above	0 to 5	92
Utility trenches within structural areas	--	96
Roadbase and subbase	-	96
Non-structural fill	0 to 5	90

Structural fills greater than 5 feet thick are not anticipated at the site. For best compaction results, we recommend that the moisture content for structural fill/backfill be within 2% of optimum. Field density tests should be performed on each lift as necessary to verify that proper compaction is being achieved.

6.5 Utility Trenches

For the bedding zone around the utility, we recommend utilizing sand bedding fill material that meets current APWA⁸ requirements.

All utility trench backfill material below structurally loaded facilities (foundations, floor slabs, flatwork, parking lots/drive areas, etc.) should be placed at the same density requirements established for structural fill in the previous section.

Most utility companies and local governments are requiring Type A-1a or A-1b (AASHTO Designation) soils (sand/gravel soils with limited fines) be used as backfill over utilities within public rights of way, and the backfill be compacted over the full depth above the bedding zone to at least 96% of the maximum dry density as determined by AASHTO T-180 (ASTM D-1557).

Where the utility does not underlie structurally loaded facilities and public rights of way, natural soils may be utilized as trench backfill above the bedding layer, provided they are properly moisture conditioned and compacted to the minimum requirements stated above in **Section 6.4**.

⁷ American Association of State Highway and Transportation Officials

⁸ American Public Works Association

6.6 Stabilization

The natural soils at this site will likely be susceptible to rutting and pumping. The likelihood of disturbance or rutting and/or pumping of the existing natural soils is a function of the soil moisture content, the load applied to the surface, as well as the frequency of the load. Consequently, rutting and pumping can be minimized by avoiding concentrated traffic, minimizing the load applied to the surface by using lighter equipment and/or partial loads, by working in drier times of the year, or by providing a working surface for the equipment. Rubber-tired equipment particularly, because of high pressures, promotes instability in moist/wet, soft soils.

If rutting or pumping occurs, traffic should be stopped and the disturbed soils should be removed and replaced with stabilization material. Typically, a minimum of 18 inches of the disturbed soils must be removed to be effective. However, deeper removal is sometimes required.

To stabilize soft subgrade conditions (if encountered), a mixture of coarse, clean, angular gravels and cobbles and/or 1.5- to 2.0-inch clean gravel should be utilized, as indicated above in **Section 6.3**. Often the amount of gravelly material can be reduced with the use of a geotextile fabric such as Mirafi RS280i or equivalent. Its use will also help avoid mixing of the subgrade soils with the gravelly material. After excavating the soft/disturbed soils, the fabric should be spread across the bottom of the excavation and up the sides a minimum of 18 inches. Otherwise, it should be placed in accordance with the manufacturer's recommendation, including proper overlaps. The gravel material can then be placed over the fabric in compacted lifts as described above.

7.0 FOUNDATION RECOMMENDATIONS

The following recommendations have been developed on the basis of the previously described project characteristics, including the maximum loads discussed in **Section 1.3**, the subsurface conditions observed in the field and the laboratory test data, and standard geotechnical engineering practice.

7.1 Foundation Recommendations

Based on our geotechnical engineering analyses, the proposed structure may be supported upon conventional spread and/or continuous wall foundations placed entirely on suitable, undisturbed natural soils, entirely on structural fill extending to suitable natural soils or competent bedrock, or entirely on competent bedrock. Footings may be designed using a net bearing pressure of 2,000 psf if placed on suitable, undisturbed, natural soils or 2,500 psf if placed on a minimum 18 inches of structural fill extending to suitable natural soils, or 3,000 psf if placed on structural fill extending to bedrock or if placed on the bedrock.

The term "net bearing pressure" refers to the pressure imposed by the portion of the structure located above lowest adjacent final grade, thus the weight of the footing and backfill to lowest adjacent final grade need not be considered. The allowable bearing pressure may be increased by 1/3 for temporary loads such as wind and seismic forces.

We also recommend the following:

1. Exterior footings subject to frost should be placed at least 36 inches below final grade.
2. Interior footings not subject to frost should be placed at least 16 inches below grade.
3. Continuous footing widths should be maintained at a minimum of 18 inches.
4. Spot footings should be a minimum of 24 inches wide.

7.2 Installation

Under no circumstances shall foundations be placed on undocumented fill (if encountered), topsoil with organics, sod, rubbish, construction debris, other deleterious materials, frozen soils, or within ponded water. If other unsuitable soils are encountered, they must be completely removed and replaced with properly compacted structural fill. Deep, large roots may be encountered where trees and larger bushes are located or were previously located at the site; such large roots should be removed.

Also, to reduce the potential for differential settlement we recommend that foundations be placed on uniform soils and not on combinations such as partly on natural soils and partly on structural fill, or partly on structural fill and partly on bedrock.

The base of footing excavations should be observed by a CMT geotechnical engineer to assess if suitable bearing soils have been exposed.

All structural fill should meet the requirements for such, and should be placed and compacted in accordance with **Section 6** above. The width of structural replacement fill below footings should be equal to the width of the footing plus 1 foot for each foot of fill thickness. For instance, if the footing width is 2 feet and the structural fill depth beneath the footing is 2 feet, the fill replacement width should be 4 feet, centered beneath the footing.

The minimum thickness of structural fill below footings should be equivalent to one-third the thickness of structural fill below any other portion of the foundations. For example, if the maximum depth of structural fill is 6 feet, all footings for the new structure should be underlain by a minimum 2 feet of structural fill.

7.3 Estimated Settlement

Foundations designed and constructed in accordance with our recommendations could experience some settlement, but we anticipate that total settlements of footings founded as recommended above will not exceed 1 inch, with differential settlements on the order of 0.5 inches over a distance of 25 feet. We expect approximately 50% of the total settlement to initially take place during construction.

7.4 Lateral Resistance

Lateral loads imposed upon foundations due to wind or seismic forces may be resisted by the development of passive earth pressures and friction between the base of the footings and the supporting soils. In determining frictional resistance, a coefficient of 0.30 for natural soils or 0.40 for structural fill, and 0.45 for bedrock, may be

utilized for design. Passive resistance provided by properly placed and compacted existing natural soils above the water table may be considered equivalent to a fluid with a density of 350 pcf. A combination of passive earth resistance and friction may be utilized if the friction component of the total is divided by 1.5.

8.0 LATERAL EARTH PRESSURES

The lateral earth pressure values given below anticipate that existing natural soils will be used as backfill material, placed and compacted in accordance with the recommendations presented herein. If other soil types will be used as backfill, we should be notified so that appropriate modifications to these values can be provided, as needed.

The lateral pressures imposed upon subgrade facilities will depend upon the relative rigidity and movement of the backfilled structure. Following are the recommended lateral pressure values, which also assume that the soil surface behind the wall is horizontal and that the backfill within 3 feet of the wall will be compacted with hand-operated compacting equipment.

CONDITION	STATIC (psf/ft)*	SEISMIC (psf)*
Active Pressure (wall is allowed to yield, i.e. move away from the soil, with a minimum 0.001H movement/rotation at the top of the wall, where "H" is the total height of the wall)	40	11
At-Rest Pressure (wall is not allowed to yield)	60	N/A
Passive Pressure (wall moves into the soil)	350	65

*Equivalent Fluid Pressure (applied at 1/3 Height of Wall)

*Equivalent Fluid Pressure (added to static and applied at 1/3 Height of Wall)

9.0 FLOOR SLABS

Floor slabs may be established entirely upon suitable, undisturbed, natural soils, or entirely on structural fill extending to suitable natural soils or bedrock (same as for foundations). Under no circumstances shall floor slabs be established directly on any topsoil, undocumented fills, loose or disturbed soils, sod, rubbish, construction debris, other deleterious materials, frozen soils, or within ponded water.

In order to facilitate curing of the concrete, we recommend that floor slabs be directly underlain by at least 4 inches of "free-draining" fill, such as "pea" gravel or 3/4-inch to 1-inch minus, clean, gap-graded gravel. To help control normal shrinkage and stress cracking, the floor slabs should have the following features:

1. Adequate reinforcement for the anticipated floor loads with the reinforcement continuous through interior floor joints;
2. Frequent crack control joints; and
3. Non-rigid attachment of the slabs to foundation walls and bearing slabs.

10.0 DRAINAGE RECOMMENDATIONS

It is important to the long-term performance of foundations and floor slabs that water not be allowed to collect near the foundation walls and infiltrate into the underlying soils. We recommend the following:

1. All areas around the structure should be sloped to provide drainage away from the foundations. We recommend a minimum slope of 4 inches in the first 10 feet away from the structure. This slope should be maintained throughout the lifetime of the structure.
2. All roof drainage should be collected in rain gutters with downspouts designed to discharge at least 10 feet from the foundation walls or well beyond the backfill limits, whichever is greater.
3. Adequate compaction of the foundation backfill should be provided. We suggest a minimum of 90% of the maximum laboratory density as determined by ASTM D-1557. Water consolidation methods should not be used under any circumstances.
4. Landscape sprinklers should be aimed away from the foundation walls. The sprinkling systems should be designed with proper drainage and be well-maintained. Over watering should be avoided.
5. Other precautions that may become evident during construction.

11.0 PAVEMENTS

All pavement areas must be prepared as discussed above in **Section 6.1**. Under no circumstances shall pavements be established over topsoil, undocumented fills (if encountered), loose or disturbed soils, sod, rubbish, construction debris, other deleterious materials, frozen soils, or within ponded water.

In pavement areas, subsequent to stripping and prior to the placement of pavement materials, the exposed subgrade must be proof rolled by passing moderate-weight rubber tire-mounted construction equipment over the surface at least twice. If excessively soft or otherwise unsuitable soils are encountered, we recommend they be removed to a minimum of 18 inches below the subgrade level and replaced with structural fill.

We anticipate the natural clay soils will exhibit poor pavement support characteristics when saturated or nearly saturated. Based on our laboratory testing experience with similar soils, our pavement design utilized a California Bearing Ratio (CBR) of 3 for the natural clay soils.

Given the projected traffic as discussed above in **Section 1.3**, the following pavement sections are recommended for approximately 4 ESAL's (18-kip equivalent single-axle loads) per day:

MATERIAL	PAVEMENT SECTION THICKNESS (inches)	
Asphalt	3	3
Road-Base	10	6
Subbase	0	6
Total Thickness	13	15

Untreated base course (UTBC) should conform to city specifications, or to 1-inch-minus UDOT specifications for A-1-a/NP, and have a minimum CBR value of 70%. Material meeting our specification for structural fill can be used for subbase, as long as the fines content (percent passing No. 200 sieve) does not exceed 15%. Roadbase and subbase material should be compacted as recommended above in **Section 6.4**. Asphalt material generally should conform to APWA requirements, having a ½-inch maximum aggregate size, a 75-gradation Superpave mix containing no more than 15% of recycled asphalt (RAP) and a PG58-28 binder.

For dumpster pads, we recommend a pavement section consisting of 6.5 inches of Portland cement concrete and 6 inches of aggregate base over properly prepared suitable natural subgrade or site grading structural fills extending to suitable natural soils. Dumpster pads constructed overlying undocumented fills must be heavily reinforced.

12.0 QUALITY CONTROL

We recommend that CMT be retained as part of a comprehensive quality control testing and observation program. With CMT on-site we can help facilitate implementation of our recommendations and address, in a timely manner, any subsurface conditions encountered which vary from those described in this report. Without such a program CMT cannot be responsible for application of our recommendations to subsurface conditions which may vary from those described herein. This program may include, but not necessarily be limited to, the following:

12.1 Field Observations

Observations should be completed during all phases of construction such as site preparation, foundation excavation, structural fill placement and concrete placement.

12.2 Fill Compaction

Compaction testing by CMT is required for all structural supporting fill materials. Maximum Dry Density (Modified Proctor, ASTM D-1557) tests should be requested by the contractor immediately after delivery of any fill materials. The maximum density information should then be used for field density tests on each lift as necessary to ensure that the required compaction is being achieved.

12.3 Excavations

All excavation procedures and processes should be observed by a geotechnical engineer from CMT or their representative. In addition, for the recommendations in this report to be valid, all backfill and structural fill placed in trenches and all pavements should be density tested by CMT. We recommend that freshly mixed concrete be tested by CMT in accordance with ASTM designations.

13.0 LIMITATIONS

The recommendations provided herein were developed by evaluating the information obtained from the subsurface explorations and soils encountered therein. The exploration logs reflect the subsurface conditions only at the specific location at the particular time designated on the logs. Soil and ground water conditions may differ from conditions encountered at the actual exploration locations. The nature and extent of any variation in the explorations may not become evident until during the course of construction. If variations do appear, it may become necessary to re-evaluate the recommendations of this report after we have observed the variation.

Our professional services have been performed, our findings obtained, and our recommendations prepared in accordance with generally accepted geotechnical engineering principles and practices. This warranty is in lieu of all other warranties, either expressed or implied.

We appreciate the opportunity to be of service to you on this project. If we can be of further assistance or if you have any questions regarding this project, please do not hesitate to contact us at (801) 492-4132. To schedule materials testing, please call (801) 381-5141.

APPENDIX

**SUPPORTING
DOCUMENTATION**

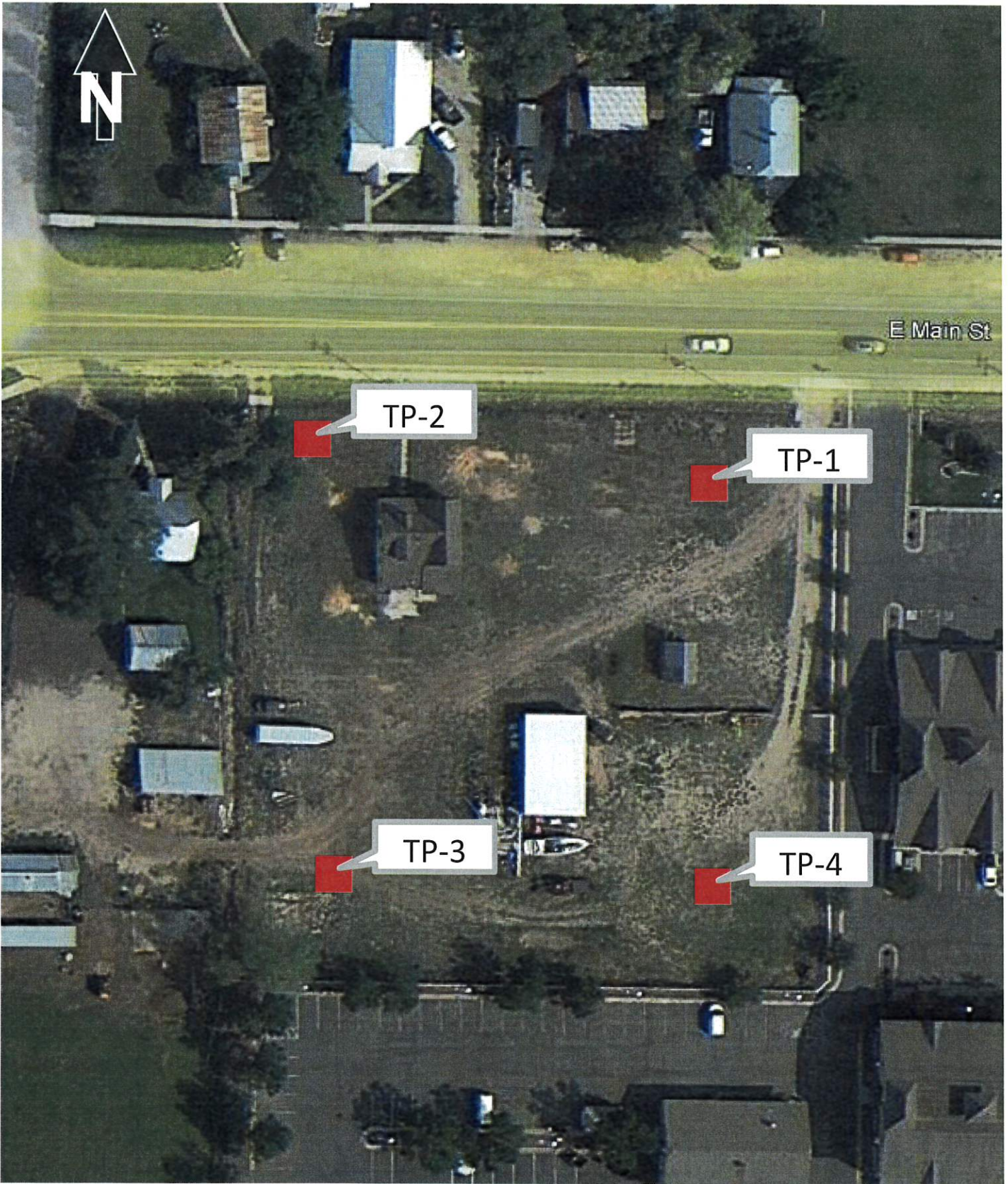

Midway Arts Center

330-368 E. Main St., Midway, UT

CMT TECHNICAL SERVICES

Site Map

Date: 2-May-22

Job # 18372

Figure:

1

Midway Arts Center

330-368 E. Main St., Midway, UT

Test Pit Log

TP-1

Total Depth: 1.5'

Date: 4/28/22

Water Depth: (see Remarks)

Job #: 18372

Depth (ft)	GRAPHIC LOG	Soil Description	Sample Type	Sample #	Moisture (%)	Dry Density(pcf)	Gradation			Atterberg		
							Gravel %	Sand %	Fines %	LL	PL	PI
0		TOPSOIL: Brown silty sand, organics										
1		CLAY (CL), slightly moist, brown medium stiff (estimated)		1	7					33	21	12
2		EXCAVATOR REFUSAL ON BEDROCK AT 1.5 FEET										
3												
4												
5												
6												
7												
8												
9												
10												
11												
12												
13												
14												

Remarks: Groundwater not encountered during excavation.

Coordinates: 40.5119°, -111.4647°

Surface Elev. (approx): Not Given

Equipment: Rubber Tire Backhoe

Excavated By: CMT

Logged By: A. Smoot

Figure:

2



Midway Arts Center

330-368 E. Main St., Midway, UT

Test Pit Log



TP-2

Total Depth: 1.5'

Date: 4/28/22

Water Depth: (see Remarks)

Job #: 18372

Depth (ft)	GRAPHIC LOG	Soil Description	Sample Type	Sample #	Moisture (%)	Dry Density (pcf)	Gradation			Atterberg		
							Gravel %	Sand %	Fines %	LL	PL	PI
0		TOPSOIL: Brown silty sand, organics										
1		Sandy CLAY (CL), slightly moist, brown medium stiff (estimated)		2								
2		EXCAVATOR REFUSAL ON BEDROCK AT 1.5 FEET										
3												
4												
5												
6												
7												
8												
9												
10												
11												
12												
13												
14												

Remarks: Groundwater not encountered during excavation.

Coordinates: 40.5118°, -111.4653°

Surface Elev. (approx): Not Given

Equipment: Rubber Tire Backhoe

Excavated By: CMT

Logged By: A. Smoot

Figure:

3



Midway Arts Center

330-368 E. Main St., Midway, UT

Test Pit Log

TP-3

Total Depth: 3'

Date: 4/28/22

Water Depth: (see Remarks)

Job #: 18372

Depth (ft)	GRAPHIC LOG	Soil Description	Sample Type	Sample #	Moisture (%)	Dry Density(pcf)	Gradation			Atterberg		
							Gravel %	Sand %	Fines %	LL	PL	PI
0		TOPSOIL: Brown silty sand, organics										
1		Silty-Clayey SAND (SM-SC), slightly moist, brown, roots medium dense (estimated)										
2				3	18				39			
2		BEDROCK: Potrock (Tuft), white very dense (estimated)										
3		EXCAVATOR REFUSAL ON BEDROCK AT 3.0 FEET										
4												
5												
6												
7												
8												
9												
10												
11												
12												
13												
14												

Remarks: Groundwater not encountered during excavation.

Coordinates: 40.5114°, -111.4654°

Surface Elev. (approx): Not Given

Equipment: Rubber Tire Backhoe

Excavated By: CMT

Logged By: A. Smoot



Figure:

4

Midway Arts Center

330-368 E. Main St., Midway, UT

Test Pit Log

TP-4

Total Depth: 2'

Date: 4/28/22

Water Depth: (see Remarks)

Job #: 18372

Depth (ft)	GRAPHIC LOG	Soil Description	Sample Type	Sample #	Moisture (%)	Dry Density(pcf)	Gradation			Atterberg		
							Gravel %	Sand %	Fines %	LL	PL	PI
0		TOPSOIL: Brown silty sand, organics										
1		Silty-Clayey SAND (SM-SC), slightly moist, brown, roots medium dense (estimated)		4	11				14			
2		BEDROCK: Potrock (Tuft), white very dense (estimated)										
		EXCAVATOR REFUSAL ON BEDROCK AT 2.0 FEET										
3												
4												
5												
6												
7												
8												
9												
10												
11												
12												
13												
14												

Remarks: Groundwater not encountered during excavation.

Coordinates: °, °

Surface Elev. (approx): Not Given

Equipment: Rubber Tire Backhoe

Excavated By: CMT

Logged By: A. Smoot



Figure:

5

Midway Arts Center

330-368 E. Main St., Midway, UT

Key to Symbols

Date: 4/28/22

Job #: 18372

①	②	③	④	⑤	⑥	⑦	⑧	⑨				
Depth (ft)	GRAPHIC LOG	Soil Description	Sample Type	Sample #	Moisture (%)	Dry Density(pcf)	Gravel %	Sand %	Fines %	LL	PL	PI

COLUMN DESCRIPTIONS

- ① **Depth (ft.):** Depth (feet) below the ground surface (including groundwater depth - see water symbol below).
- ② **Graphic Log:** Graphic depicting type of soil encountered (see ② below).
- ③ **Soil Description:** Description of soils encountered, including Unified Soil Classification Symbol (see below).
- ④ **Sample Type:** Type of soil sample collected at depth interval shown; sampler symbols are explained below-right.
- ⑤ **Sample #:** Consecutive numbering of soil samples collected during field exploration.
- ⑥ **Moisture (%):** Water content of soil sample measured in laboratory (percentage of dry weight of sample).
- ⑦ **Dry Density (pcf):** The dry density of a soil measured in laboratory (pounds per cubic foot).
- ⑧ **Gradation:** Percentages of Gravel, Sand and Fines (Silt/Clay), obtained from lab test results of soil passing the No. 4 and No. 200 sieves.
- ⑨ **Atterberg:** Individual descriptions of Atterberg Tests are as follows:
LL = Liquid Limit (%): Water content at which a soil changes from plastic to liquid behavior.
PL = Plastic Limit (%): Water content at which a soil changes from liquid to plastic behavior.
PI = Plasticity Index (%): Range of water content at which a soil exhibits plastic properties (= Liquid Limit - Plastic Limit).

STRATIFICATION		MODIFIERS	MOISTURE CONTENT
Description	Thickness	Trace	
Seam	Up to ½ inch	<5%	Dry: Absence of moisture, dusty, dry to the touch.
Lense	Up to 12 inches	Some	Moist: Damp / moist to the touch, but no visible water.
Layer	Greater than 12 in.	5-12%	
Occasional	1 or less per foot	With	Wet: Visible water, usually soil below groundwater.
Frequent	More than 1 per foot	> 12%	

UNIFIED SOIL CLASSIFICATION SYSTEM (USCS)	MAJOR DIVISIONS		USCS SYMBOLS	②	TYPICAL DESCRIPTIONS
	COARSE-GRAINED SOILS More than 50% of material is larger than No. 200 sieve size.	GRAVELS The coarse fraction retained on No. 4 sieve.	CLEAN GRAVELS (< 5% fines)	GW	
GRAVELS WITH FINES (≥ 12% fines)			GP		Poorly-Graded Gravels, Gravel-Sand Mixtures, Little or No Fines
			GM		Silty Gravels, Gravel-Sand-Silt Mixtures
GC				Clayey Gravels, Gravel-Sand-Clay Mixtures	
		SANDS The coarse fraction passing through No. 4 sieve.	CLEAN SANDS (< 5% fines)	SW	
SANDS WITH FINES (≥ 12% fines)			SP		Poorly-Graded Sands, Gravelly Sands, Little or No Fines
			SM		Silty Sands, Sand-Silt Mixtures
SC				Clayey Sands, Sand-Clay Mixtures	
FINE-GRAINED SOILS More than 50% of material is smaller than No. 200 sieve size.		SILTS AND CLAYS Liquid Limit less than 50%	ML		Inorganic Silts and Sandy Silts with No Plasticity or Clayey Silts with Slight Plasticity
			CL		Inorganic Clays of Low to Medium Plasticity, Gravelly Clays, Sandy Clays, Silty Clays, Lean Clays
	OL			Organic Silts and Organic Silty Clays of Low Plasticity	
	SILTS AND CLAYS Liquid Limit greater than 50%	MH		Inorganic Silts, Micaceous or Diatomaceous Fine Sand or Silty Soils	
		CH		Inorganic Clays of High Plasticity, Fat Clays	
		OH		Organic Silts and Organic Clays of Medium to High Plasticity	
HIGHLY ORGANIC SOILS		PT		Peat, Soils with High Organic Contents	

- ### SAMPLER SYMBOLS
- Block Sample
 - Bulk/Bag Sample
 - Modified California Sampler
 -
 - D&M Sampler
 - Rock Core
 - Standard Penetration Split Spoon Sampler
 - Thin Wall (Shelby Tube)

- ### WATER SYMBOL
- Encountered Water Level
 - Measured Water Level
- (see Remarks on Logs)

Note: Dual Symbols are used to indicate borderline soil classifications (i.e. GP-GM, SC-SM, etc.).

- The results of laboratory tests on the samples collected are shown on the logs at the respective sample depths.
- The subsurface conditions represented on the logs are for the locations specified. Caution should be exercised if interpolating between or extrapolating beyond the exploration locations.
- The information presented on each log is subject to the limitations, conclusions, and recommendations presented in this report.

Figure:

APPENDIX 6 – CLOCK TOWER VIEW ISSUES

The Clock Tower



- A new photo study of all buildings on main street was completed in May.
- The study would indicate the current height restriction was not intended to preserve views of Timp.
- Virtually all buildings, including those with heights well below the allowed 35' height, block the view of Timp when seen from the street and south sidewalk.

The Clock Tower



We would like the City to consider an exception for the clock tower because it dramatically improves the beauty of the building.



The MAC and Millstream Property



The MAC and Millstream Property



The Clock Tower

- Proposed tower height - 68 feet
- Required setback - 25.5 feet
- Current setback as shown - 50 feet
- Current set-back as shown enhances the beauty of both the views and the landscaping



APPENDIX 7 – PUBLIC AND BUSINESS SUPPORT

Public & Business Support

1. Zermatt and Homestead signed new letters of support in June, 2022.
2. Midway City Council signed a letter of support for an arts center Nov. 2021
3. Fifteen prominent citizens signed letters of support.
4. 537 Midway residents have signed a petition in favor of The MAC.
5. 10,500 people attended HVAF shows in 2021.
6. HVAF, the resident theater company of The MAC, involves more people in events than any other Midway organization except Swiss Days.



**CURRENT
SUPPORT LETTERS
FROM MIDWAY
RESORTS**



700 North Homestead Drive, Midway UT 84049
435-657-3806

May 28, 2022

Dear Honorable Council and Commission Members,

The team here at Homestead resort is looking forward to the possibility of the Midway Arts Center and is in full support. Midway is full of unique opportunities for local and traveling guests and the MAC will be another great asset to add to the community.

As a resort, we are always looking for places to recommend nearby. The community should seek to continue to bring more venues like the MAC to the city as it will bring revenue to our community and have a great impact.

Sincerely,
Andrew Carey
Director of Hotel Operations

Mobile: 602.803.4277
Email: Andrew.Carey@homesteadresort.com

700 N Homestead Drive
PO Box 99
Midway, UT 84049

Midway City Council
Midway Planning Commission
75 N. 100 W.
Midway, Utah 84049

18 May 2022

Dear Honorable Council and Commission Members

My name is Richard Saltzman and I am the Manager of Legacy Resorts, LLC. Legacy Resorts is the owner of the Zermatt Resort and has been for many years.

I am writing in support of the Midway Art Center Foundation plan to provide a state-of-the-art performing arts center in Midway.

I am familiar with the leadership of the MAC and of High Valley Arts and their 15-year history of outstanding events in Midway. I have confidence in the plan for the MAC and firmly believe it would be a wonderful gift to the community for many years to come.

Not only would the MAC benefit the youth and adults who participate in performances, but it would continue to draw significant 'arts tourists' to Midway, as the High Valley Arts performances have consistently done in the past.

The audiences coming to the arts center would naturally benefit the businesses in Midway – from restaurants to the resorts – and everything in between. At Zermatt, we have always been looking for activities for our guests that would enhance their stay. The arts center is a perfect example of what we need to help the resort grow and stay healthy.

In short, the Zermatt is in favor of the plan to 'Bring the MAC to Midway.'

Sincerely,

A handwritten signature in black ink, appearing to read "Richard Saltzman", with a long horizontal flourish extending to the right.

Richard Saltzman, Manager
Legacy Resorts, LLC



ZERMATT UTAH

May 23, 2022

Dear Midway City Council:

The Zermatt Resort and Spa appreciates the opportunity to share its support for the proposed performing arts center in Midway, Utah. For several years, owners and guests at the resort have enjoyed the programming provided by the arts community throughout Heber Valley, including presentations of *The Christmas Carol*, *Annie*, *The Sound of Music*, *Oliver*, *The Music Man*, and many others — all performed in Midway and providing not only high quality entertainment but an opportunity for members of the community to share their gifts, individually and collectively.

A little over a year ago (May 12, 2021) Peter Rancie, then a director at the Zermatt Resort and Spa, sent a letter of support that outlined a persuasive rationale for the new venue. Among the reasons, Peter cited the need for destination amenities in Midway and the business opportunities that would benefit the city, its stores, hotels, restaurants, recreational destinations, and service outlets. All of this will result in an improved tax base for Midway City and contribute to the wonderful brand Midway already enjoys throughout Utah and the larger United States.

With this letter, I reaffirm the support articulated by Peter and offer to provide any additional information or assistance that may be necessary in this important endeavor.

All my best,



William Nixon
202.641.2882
Zermatt Resort & Spa

**LETTER OF SUPPORT
FROM MIDWAY CITY
COUNCIL, NOVEMBER
2021**

Midway City Corporation

Mayor: Celeste T. Johnson
City Council Members
Lisa Christen • Jeffery Drury
J.C. Simonsen • Steve Dougherty
Kevin Payne



75 North 100 West
P.O. Box 277
Midway, Utah 84049
Phone: 435-654-3223
Fax: 435-654-4120
midwaycityut.org

16 November 2021

To Whom It May Concern:

Midway City has long been known for its support of the arts and our cultural heritage. Midway is a community that values those events and activities that benefit our citizens, citizens of Wasatch County and our visitors. Midway has enjoyed a variety of live performing arts events including orchestra and dance performances, choruses, cowboy music, bell ringers, and theater productions for both kids and adults, among other events. These activities bring our community together.

Many of Midway's citizens have expressed their appreciation of such activities and their desire to have them continue. This letter is presented to express our support of a private, nonprofit organization which will continue hosting performing arts in Midway, including theater, dance and musical performances as well as art competitions and displays and cultural activities such as quilting, cowboy poetry, etc. We anticipate those activities would help support our retail and resort businesses and provide our citizens and visitors an opportunity to enjoy our rich cultural heritage.

We understand that a group called the Midway Arts Center Foundation is searching for and planning a venue for those purposes and we welcome the opportunity to engage in discussions with that group for the benefit of our community. This letter has the approval of all of the Midway City Council members.

Sincerely,

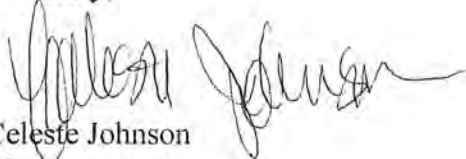

Celeste Johnson
Mayor

**FIFTEEN LETTERS OF
SUPPORT FROM
PROMINENT
CITIZENS**

Mayor Celeste Johnson and City Council (Lisa Orme, Steve Dougherty,
Jeff Drury, Kevin Payne and JC Simonsen)
75 N 100 W
Midway, City 84049

Re: High Valley Arts Center

Dear Mayor Johnson and City Council Members,

Thank you for your devoted service to our community. You are each individually and collectively an inspiration of civic service preserving our community as a choice place to live.

This is to express my support for consideration and approval of a performing arts center in Midway. I understand the current proposal is for a location at the base of Memorial Hill.

I am grateful for your care and concern to control the growth of our community. In general, I favor controlled growth. As we all know, part of the magic of our community is its small-town charm and rural character. We hope that won't be lost in the coming years.

My wife was raised in Boulder City, Nevada which years ago passed a growth ordinance limiting growth to less than 3% per year. As a result, the community of her childhood is much the same today as when she was a young girl. It retains its "small town feel" unlike its sprawling neighboring communities of Henderson and Las Vegas. Driving into Boulder City from Las Vegas/Henderson is a breath of fresh air. We all experience that same dynamic even more accentuated driving into this valley from any direction.

As for the property in question, already under development, a community arts center is far more appealing and would make a far more valuable and unique contribution to the character of Midway than additional housing, offices or commercial buildings in the same development.

We also have the advantage of knowing that such a proposal is not "pie in the sky" because High Valley Arts has demonstrated an unusual investment and devotion to the community of Midway over the years. One may question whether Midway has the population base to support such a center, but the history of High Valley Arts seems to demonstrate that it does. It is particularly timely to consider the proposal now, as we continue to be the beneficiaries of High Valley Arts dedication and devotion to our community.

Thank you for your valiant service to our community and favorable consideration of the proposal for a performing arts center in Midway.

Respectfully and gratefully,

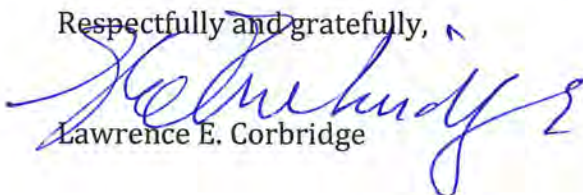

Lawrence E. Corbridge

June 17, 2021

Dear Mayor and City Council Members,

I am writing in support of the Midway Arts Center. There are several reasons that I see as a benefit to our community.

First and foremost is that art is an important aspect of all of our lives. All people benefit by art and the ability to see things from a different perspective. The performing theatrical arts are a unique form of entertainment that allows actresses and actors to interact with the audience which is something Hollywood cannot replicate.

Second, as far as I am aware this arts center is not asking for public funds to support the land purchase, building construction or ongoing expenses. Where we already have plenty of demand for our tax dollars, it is refreshing to see someone trying to do something of this nature that does not expect or demand funding.

Third, I have been to several of HVA performances and I will say that they desperately need a permanent location for rehearsal and set builds. I'm not quite sure how successful any operation of this nature can be when they have to contend with inclement weather or shared space. A dedicated facility will definitely enhance their ability to produce high quality entertainment.

Fourth, I've heard and must agree that Wasatch County needs more things to attract visitors. As I have talked to venue operators, the common message is that the more Wasatch County has to offer the more visitors it will attract. Since Midway in particular is interested maintaining the resort tax benefits, you should be looking at whatever means possible to attract more visitors and potentially more overnight lodging. Helping Zermatt and Homestead to be successful will definitely benefit Midway.

Fifth, the developer of this parcel of land will build something in this location regardless of what you decide. I think it is in the community's best interest to allow this development as opposed to additional housing.

Sincerely,
Marilyn Crittenden

June 23, 2021

My name is Ali Dabier, current president of the Midway Boosters and a longtime member of the Booster's Board. The Midway Boosters as a body of community volunteers dedicate much time for the betterment of our community not only for its citizens and inhabitants, but also for those that come to visit during all seasons and enjoy our beautiful mountains, lakes and trails, not to mention the Swiss day tradition that has lasted 73 years so far. We also generate significant funds that goes toward national and international humanitarian services, various youth and adult art and music programs and education scholarships. We are proud of our community and the hundreds of volunteers that share the same vision. Having a performing art center will further enhance the reputation and desirability of this community. For years my wife and I have been the beneficiaries of the performances that were offered by the High Valley Arts organization. It, not only has produced high quality performances but also has engaged many of our talented community members. We have enjoyed sitting on the grass during the outdoor performances, but welcome a permanent venue and all that it can offer throughout the year to our wonderful community and its visitors. I fully support the building of the Performing art center at the base of the ever so prominent Memorial Hill.

Sincerely

Ali Dabier

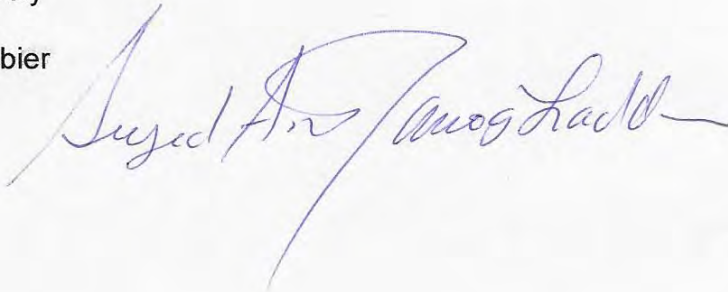
A handwritten signature in blue ink, appearing to read "Ali Dabier", with a long, sweeping flourish extending to the right.

From: Steve Eddington skeddington@gmail.com
Subject: High Valley Arts
Date: March 27, 2021 at 10:39 AM
To: Susan Waldrip suewaldrip@hotmail.com
Cc: Stuart Waldrip stuwaldrip@me.com



Sue,

You, Stu and the High Valley Arts Foundation family can count on those of us who have watched, observed and participated with you, in some way, with the ongoing development of quality theater in Wasatch County.

During the past several years my position as managing member of the Zermatt Resort and Spa and The Homestead Resort has enabled our resorts, city and county to realize the economic value of High Valley Arts especially during your professional productions.

The thought of a quality theater in the Midway area that is open during every season multiplies the value of our resorts and surrounding area exponentially.

Thank you for your theater center vision and action that will help change the value for all of us who live in the area and who have personal and professional area interests.

Best Regards,

Steve Eddington
(Former Managing Partner for Zermatt and The Homestead Resorts 2010-2020)

Sent from my iPhone

As a Vietnam Veteran, I'm honored and proud to have my name with so many others on one of the plaques at the top of Memorial Hill. We must never forget those who made the sacrifice to defend freedom and the liberties we so freely enjoy in this country, state and valley. We need to keep those remembrances in our hearts and minds.

The proposed Midway Arts Center will help us do just that as they present "Let Freedom Ring" programs and events that will engage youth and adults alike with enjoyable and teaching productions that will reinvigorate our feelings towards our freedoms and rights and propel the next generation toward preserving the same.

Not only will the Midway Arts Center help us preserve freedom ["Let Freedom Ring"], but the placement of the Center will help preserve the view of Memorial Hill so that it will remain a beacon and a reminder to all of us of those few who have sacrificed so much for so many.

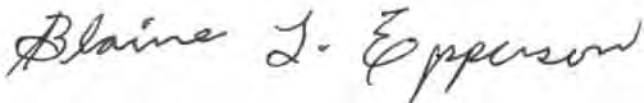
Signed, 

Blaine Epperson
Vietnam Veteran - Specialist 4th Class
A relative of Sidney H. Epperson, one of Midway's original Pioneers

May 18, 2021

Midway City Council

To whom it may concern,

We moved to this beautiful valley and city about 9 years ago. Shortly thereafter, we became introduced to the summer and winter plays put on by the Midway Arts Center. We started inviting our friends and relatives from Salt Lake up to visit and see the plays with us. The talent is amazing we have in this valley and everyone recognizes this as a huge asset.

We believe the Performing Arts Center needs to be built in Midway and would be a huge asset in attracting more people to visit and spend money here in Midway.

We hope the City Council can have the vision as well to help the PAC be built on the Main Street side of Memorial Hill.

Thank you for your help in advancing this wonder cause in our city.

Sincerely,



Nathan Hanks

Cary Hobbs:

I like the idea of having an outlet for art and entertainment in Midway to augment the already well-known tourist and community activities in our city. We need as much of that as we can get! This will be an opportunity to attract people from all over the world to our unique community and to give residents a chance to participate in and enjoy dramatic productions. It would be another reason for us to brag that there's no better place to live than in Midway, Utah!

BARRY L KENT
1420 S 200 W, Midway, UT

Midway City Council,

May 17, 2021

I would like to provide my strong support for a Performing Arts Center in Midway along with the proposed location South of Memorial Hill as part of the European Village concept.

Having a Performing Arts Center in Midway on Mainstreet is a once in a lifetime opportunity. It is a legacy opportunity to show others in the future what we value most. No other group over the past several years has proposed anything even close to the vision of the Midway Arts Center along with the millions of dollars of funding they will bring to our community along with the positive tax and destination revenue impact. Midway is unique amongst all Utah small towns. A Performing Arts Center will add to everything Midway and be additive to what visitors are hoping to find when they visit.

We are all witnessing the powerful market forces that are in play that every available piece of property in Midway will be developed. Taking no action on the MAC is a vote for more housing development.

I would like to respectfully ask for each of the city council members support for a Performing Arts Center in Midway.

Sincerely,

Barry Kent

June 22, 2021

Re: Midway Performing Arts Center

I am in support of a performing arts center in Midway. Our charming mountain village is growing rapidly and an obvious destination. I believe we would benefit from a modest arts center. The proposal, which has been developing in recent years seems to have many advantages – if it can be fit into our wonderful community. While there are many challenges to a project like this, I am in favor of our trying to make it happen!

Thanks,

Mark

Mark Nelson

Midway resident and member of the Wasatch County Council

Dear Mayor and City Council Members,

This letter is written in support of the proposed Midway Arts Center.

For years I have watched as the founders of High Valley Arts and many other dedicated individuals have worked tirelessly to provide high quality and wholesome theatrical productions for the enjoyment of Wasatch County residents and visitors. This has been done cooperatively with other production companies, sponsors, and neighbors. The large number of committed people are a clear indication of continued interest and the ability to marshal required resources to make the MAC a reality. This is a concept that has a sound foundation of experience and professional expertise.

These individuals have overcome challenges; uncertain weather, parking, venue construction and maintenance, and other obstacles with determination and diplomacy. Midway City leaders have the past fourteen years of history showing that the production companies will be consistent with the values that attract many to visit Midway.

The land south of Memorial Hill, where two main roads meet, is a natural location for a hub supported by the MAC. It is easily identified by visitors and readily accessible through Memorial Hill Road or Main Street.

Events like Swiss Days and the Sheep Dog Trials have created thousands of ambassadors for Midway. The visitors feel as though they have gone to a foreign land and been greeted by gracious and welcoming residents. The design and character of the MAC will enhance the feel of escaping for a time to a foreign land.

While growth continues to be the topic of discussion among existing residents of Wasatch County, many of us believe that growth will occur overtime regardless of policy. Decision-makers have the unpopular job of ensuring that growth is consistent with the values and character of the community. Maintaining a defined city vision while bearing in mind inevitable growth is the responsibility of leaders. Attractive communities happen over time with visionary policies at the headwaters. Discord and contention within communities are avoided with a well-defined vision in place. As presented, the MAC can be a unifying vision for Midway City.

The MAC supports Midway City and the County in many positive ways. It creates ambassadors, represents our values, produces tax revenues, and maintains the Swiss/European theme.

Respectfully,

Michael Nelson

From: Nancy Norton <nortonsgarden@aol.com>
Subject: High valley arts
Date: June 17, 2021 at 7:22:49 PM MDT
To: suewardrip@me.com

This is Nancy Norton
I'm sending you a note regarding the high valley arts program. You were so very helpful getting me the tickets for 7 brides for 7 brothers
You asked for a short note from our group. Hope this works. And feel free to edit.

Our group from Palm Desert, ca have been coming to Park City for many years. One of our favorite activities has been the Summer High Valley Arts play in Midway.. We started with 8 of us and what a shock when we realized that we were in a LARGE field, watching the most wonderful play by extremely talented people. Every year since our group has grown and we're now up to 22. It is one of the highlights of the summer for ALL of us
Thank you High Valley Arts
Especially. Sue and Stewart



ZERMATT  UTAH

May 12, 2021

**TO WHOM IT MAY CONCERN
SUPPORT FOR A PERFORMING ARTS CENTER IN MIDWAY CITY**

I can only speak directly for Zermatt, but I believe my views accurately represent the resort operators which are the largest private employers in Midway and the Heber Valley.

Is there a need for a viable performing arts center in Midway? The answer is an unequivocal, yes. Should the PAC be located at the proposed site within the European Village concept on the Main Street side of Memorial Hill? The answer is an unequivocal, yes.

This initiative will provide a significant contribution to the viability of Midway City's entire economy, including the resorts.

It must be common knowledge — certainly in Council circles — that Midway's two major resorts have been struggling for years to maintain profitability. This is largely due to the lack of destination amenities in Midway. The destination-quality PAC will certainly attract many new overnight stays, helping to bridge the occupancy gap. Yes, there will be more day visitors too, but overnight stays in hotels have a demonstrable impact on increased spending at other local venues. The PAC means an improved tax base for Midway City, along with an energetic uplift to the local entertainment and retail scene.

I would be happy to discuss the PAC in the context of its economic impact on the resorts and Midway City in more detail at any time, with Council members, or with other interested parties.

Very truly yours,

Peter R. Rancie

For communication purposes re this matter:
email: peter.rancie@gmail.com | cell: 435.901.0601

Watts

May 17, 2021

Midway City Council

Dear Midway City Council and City Leaders,

We are writing to express our support of the Midway Arts Council to build the Performing Arts Center to be located at the base of Memorial Hill on Main Street.

We feel it would greatly benefit the Midway Community and create a cultural destination to have such a fine Arts Center in the valley. We need a lot of visitors to come to Midway. Having this Arts Center will give them another activity to do while visiting and it will help drive our economy and create more tax base.

Sincerely,

A handwritten signature in black ink, appearing to read "Russ and Diane Watts". The signature is written in a cursive, flowing style.

Russ and Diane Watts

RKW/mf

Randon W. Wilson, J.D.
P.O. Box 1025
Midway, Utah 84049

To Whom It May Concern:

May 17, 2021

Re: Midway Arts Center

Gayle and I built a 2nd home in Midway Farms on Farm Road in 1978 and we moved here full time in 1999. We served on Midway Boosters for six (6) years, organized Midway Heritage Foundation, started the Midway Swiss Days Pin Collection, and were recognized as Midway honored citizens in 2014.

We love Midway and our family recognizes it as our "homestead". We understand the issues of growth, taxation, infrastructure and the importance of making "ends meet." We especially appreciate the visitors who come here to stay at our resorts and other places of lodging as they bring revenue without stressing the infrastructure.

We have long appreciated the performing arts and other arts groups for the quality of life that they bring and we hope that we will be able to construct facilities that will help them remain an enduring legacy for Midway.

We are strongly in favor of the proposed Midway Art Center to be constructed south of Memorial Hill as part of a mixed use development that will perpetuate the performing arts and preserve open space while at the same time attracting visitors who will contribute to our economic well being. We understand that traffic patterns and other issues will have to be dealt with, but we are confident that our leaders will be able to do so. It is our hope that Midway City Council will recognize the substantial benefits that will come to Midway through the Midway Arts Center.

Yours very truly,

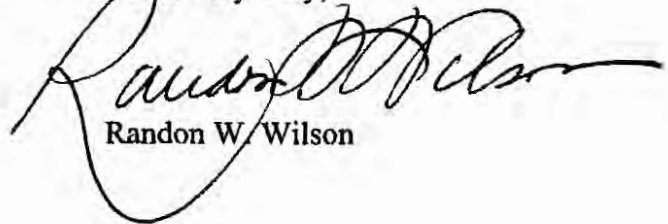

Randon W. Wilson

JOHN H. & HOLLY ZENGER
275 LUZERN RD.
P.O. BOX 1268
MIDWAY, UT 84049

To Whom It May Concern:
May 19, 2021

Concerning the proposed Midway Arts Center

We have lived in Midway since 1996 when we occupied our current home. We have attempted to be good citizens of this community through serving on the Booster Board for several terms and functioning in various leadership roles. Holly initiated the public, interfaith displays of Nativity scenes; which have contributed to the culture and traditions of the community.

The community is fortunate to have many talented people who are dedicated to the performing arts. We are aware that there is a group seeking to spearhead the construction of a performing arts center that could permanently provide an excellent performance venue, as well as rehearsal facilities. It would be available to a variety of musical and artistic groups who will benefit from a well-designed and equipped facility. Modern lighting and sound systems greatly enhance these performances. These performing groups and the physical building that would support this endeavor will combine to attract visitors, and make the community an even more attractive home for all residents.

We support the location on the Main Street side of Memorial Hill. It provides accessibility and visibility for this arts center. We do not believe it detracts from the worthy purpose or message that Memorial Hill offers.

We encourage the elected leaders of our community to support to the groups that are working hard to make this happen. We are aware that there are many worthy causes and projects seeking your backing. At the same time, we think these performing groups bring a vibrant and unique dimension to our community. We hope this will be part of the legacy for which you will be remembered.

Warm regards,

John H. Zenger

Holly Zenger

- 537 PETITIONS FROM
MIDWAY VOTERS

- 204 PETITIONS FROM
OTHERS

Petitions in favor of bringing The MAC to Midway - Midway residents

	TIME STAMP	NAME	EMAIL ADDRESS	ADDRESS	MIDWAY VOTER	COMMENTS
1	3/27/2021 14:59:47	Stuart Waldrip	stuwaldrip@me.com	817 Double Eagle Drive, Midway UT 84049	Yes	Best idea in a long time!
2	3/27/2021 20:27:53	Kimberly Charles	kimberlycharles@hotmail.com	280 E Deer Ridge Way Midway Utah 84049	Yes	
3	3/27/2021 20:27:53	Mary Scoville	Maryscoville@gmail.com	PO Box 1121, Midway, UT 84049	Yes	I vote for plan B
4	3/27/2021 21:09:41	Molly Lent	mollylent@yahoo.com	514 Craftsman Way	Yes	
5	3/27/2021 21:09:41	Steve Childs	Stevebchilds@gmail.com	1159 W. Lime Canyon rd., Midway, Utah 84049	Yes	
6	3/27/2021 21:37:43	Tami Gray	tamigray4@gmail.com	1307 N Dutch Highland Dr Midway UT 84049	Yes	
7	3/27/2021 21:38:50	Jeff Gray	solarcastlesconsulting@gmail.co	1307 N Dutch Highland Dr Midway UT 84049	Yes	
8	3/27/2021 21:38:50	Tom Reed	007reed@gmail.com	473N 680W 84049 Midway Utah	Yes	
9	3/27/2021 21:40:14	Rylee Gray	Rylee.gray67@gmail.com	360 E 400 S Heber City UT 84032	Yes	
10	3/27/2021 21:42:49	Treven Gray	trevengrayshreds@gmail.com	360 E 400 S Heber City UT 84032	Yes	
11	3/27/2021 21:45:12	Diane Owens	mamadi872@gmail.com	79 N Johnson Mill Rd	Yes	
12	3/27/2021 21:45:12	Kelli Gray	Kellibrzenk94@gmail.com	1307 N Dutch Highland Dr Midway Ut 84049	Yes	
13	3/27/2021 21:46:33	Bradley Hancock	K5blaze41@yahoo.com	PO BOX 1193, Midway UT 84049	Yes	
14	3/27/2021 21:46:33	Jade Gray	Jadejgray@gmail.com	1307 N Dutch Highland Dr Midway UT 84049	Yes	
15	3/27/2021 21:46:46	Troy Finlayson	troywf@gmail.com	1131 Dutch Fields Pkwy	Yes	
16	3/27/2021 21:55:44	Kelli Tingey	kellipt@gmail.com	954 cobblestone dr	Yes	
17	3/27/2021 22:07:40	Kathy Speakman	kmspeakman@gmail.com	730 Dutch Creek Court	Yes	
18	3/27/2021 22:07:40	Mindi Finlayson	Mindifin@gmail.com	1131 Dutch fields pkwy	Yes	
19	3/27/2021 22:34:49	Nicole Clawson	nic.clawson@gmail.com	1130 Dutch Fields Parkway Midway, UT 84049	Yes	
20	3/27/2021 23:36:24	Lillie Peery	lilliepeery@gmail.com	1595 N Dutch Meadows lane	Yes	
21	3/27/2021 23:36:24	Maggie Meyers	mshandoff@gmail.com	1273 w Lime Canyon rd	Yes	
22	3/28/2021 13:34:08	Dave Scott	dscott321@gmail.com	583 Dutch ridge court	Yes	
23	3/28/2021 13:34:08	Don Mantyla	donmantyla@gmail.com	499 Craftsman Way, Midway, UT. 84049	Yes	
24	3/28/2021 13:58:30	Sue Mantyla	suemantyla@gmail.com	626 Dutch Valley Court Midway UT. 84049	Yes	I'm grateful for people who are concerned with maintaining the integrity of Midway, for which we all have moved here to enjoy!
25	3/28/2021 22:40:02	Mark R. Dennis	markrdennis55@gmail.com	320 West Bumts Field Road, Midway Utah 84049	Yes	If we fail to plan, we plan to fail.
26	3/28/2021 22:40:02	Rachel Turley	rachelmturley@gmail.com	1131 N 520 W Midway, UT 84049	Yes	Plan B
27	3/28/2021 23:00:55	Glenda Bolick	glendabolick@gmail.com	833 Double Eagle Drive,	Yes	This will be a gift to our already-fabulously Midway.
28	3/28/2021 23:00:55	Isaac Harold Smith	iz1979us@yahoo.com	900s. Price farm ct.midway ut.84049	Yes	
29	3/29/2021 7:01:20	EJ Bowen	Erinjbowen@gmail.com	451 s 300 e Midway	Yes	This should absolutely happen to grow the community and take it to the next level.
30	3/29/2021 7:01:20	Joni Taylor	Inclinecos@yahoo.com	1270 pine canyon road, Midway UT 84049	Yes	
31	3/29/2021 7:40:42	Cary Hobbs	caryhobbs111@gmail.com	131 Ryans Lane, Midway, Ut 84049	Yes	The Arts Center would make Midway unique... would contribute to our reputation as being a beautiful place to live instead of just another strip mall, California look alike. Please do this for the generations to come!!!
32	3/29/2021 7:40:42	Christopher B Crittenden	chris.crittenden@gmail.com	99 W Fam Springs Rd, Midway UT 84049	Yes	This would be so amazing for Midway!
33	3/29/2021 7:52:03	Scott Neuner	neuner.scott@gmail.com	309 W Bumts Field Rd	Yes	
34	3/29/2021 7:52:03	Tom DeJong	tommygofast@gmail.com	PO Box 1314, Midway UT 84049	Yes	
35	3/29/2021 8:19:46	Rebekah Neuner	rebekahneuner@gmail.com	309 W Bumts Field Road	Yes	The arts enrich our lives.
36	3/29/2021 8:24:36	Scott Hardy	scotthardy77@gmail.com	510 Dutch Summit Ct	Yes	

	TIME STAMP	NAME	EMAIL ADDRESS	ADDRESS	MIDWAY VOTER	COMMENTS
37	3/29/2021 8:45:18	Jenn Iverson	jenny.iverson@gmail.com	276 Fox Den Rd., Midway, UT 84049	Yes	Theater is such an important part of our community! In order for our kids, teens, and adults to be able to develop in theater, we really need a better venue for performing. The MAC is a great plan to allow this growth in a way that preserves the beauty of our town.
38	3/29/2021 8:54:50	Karl L. Dodge	karl.l.dodge@gmail.com	975 Swiss Alpine Rd	Yes	Plan B will be a much more aesthetically pleasing option for the city. The Arts Center will also add much to the community.
39	3/29/2021 8:54:50	Lindsey brown	lindseyleavitt@gmail.com	1124 Dutch fields pkwy	Yes	We are so excited to have The MAC in our community
40	3/29/2021 8:57:01	Sarah Severson	sarahseverson10@gmail.com	252 Fox Den Rd., Midway UT 84049	Yes	
41	3/29/2021 8:59:10	Douglas D. Bames	douglasdbames@gmail.com	827 Double Eagle Drive, Midway UT 84049	Yes	
42	3/29/2021 8:59:10	Eric	Ebattles@gmail.com	1202 Dutch Fields Pkwy Midway, UT 84049	Yes	
43	3/29/2021 9:11:57	Karen S Bames	momlambert@gmail.com	827 Double Eagle Dr., Midway, UT 84049	Yes	This would be a beautiful and uplifting addition to Midway!
44	3/29/2021 9:11:57	Mark Stokes	stokesnation27@gmail.com	1465 S 200 W, Midway, Ut 84049	Yes	
45	3/29/2021 9:13:48	Brynn Nygren	brynnnygren@gmail.com	574 Cascade Meadows Loop. Midway, UT 84049	Yes	We would LOVE to have the Midway Arts Center!!! It's what this town needs. And we really want to save the view of Memorial Hill too! Thank you!
46	3/29/2021 9:35:29	Aimee Amer	agreenjeans@gmail.com	388 Cottage Creek Court	Yes	
47	3/29/2021 9:35:29	Lisa Allan	allanlisa@bellsouth.net	73 E 450 S midway Utah 84049	Yes	
48	3/29/2021 9:38:01	Bette Jo Croft	crafty1942@gmail.com	1312 North Valais Circle, Midway	Yes	
49	3/29/2021 9:38:01	Candace Croft	Croftb1@gmail.com	1087 N Matterhom Ct	Yes	
50	3/29/2021 10:10:13	Isaac Button	irbutton@gmail.com	193 w canyon view lane	Yes	
51	3/29/2021 10:10:13	Jerry Owens	Jeryleeowens@gmail.com	79 N Johnson Mill Rd	Yes	
52	3/29/2021 10:23:25	Erin Corbridge	erincorbridge1@gmail.com	402 W 1120 S, Midway, UT 84049	Yes	
53	3/29/2021 10:24:04	Tanner Corbridge	Tannerc@ozprinciple.com	402 W 1120 S, Midway, UT 84049	Yes	
54	3/29/2021 12:17:36	Carolyn Robison	carolynrobison@yahoo.com	577 N. Granary Ln	Yes	
55	3/29/2021 12:17:36	Kristen Curley	candy_cheer@yahoo.com	1369 lime canyon rd midway	Yes	
56	3/29/2021 12:18:30	Jon Robison	jrobison6@yahoo.com	577 N. Granary Ln.	Yes	
57	3/29/2021 12:18:30	Kelly Valesky	Kelly.valesky@gmail.com	190 S 200 E Midway UT 84049	Yes	
58	3/29/2021 12:27:32	Julie Button	Julieabutton@gmail.com	193 w Canyon View Ln. , Midway, Ut 84049	Yes	We value open space, particularly open space you can enjoy from the road, not behind someone building or house. Some of the open space we are preserving in midway is only enjoyable to the people who happen to back up to the open space, or when you get on top of memorial hill and can get an ariel view of things. Those are valuable but what the MAC is proposing is far more valuable to the feel and the people of midway.
59	3/29/2021 12:27:32	Mckinzie	Kinzie24@gmail.com	719 Hot Springs Dr	Yes	
60	3/29/2021 12:48:44	Melissa Stocking	Mstocking912@gmail.com	285 E. Deer Ridge Way	Yes	
61	3/29/2021 12:48:44	Tamara Potter	tampotter@gmail.com	333 E 300 N	Yes	
62	3/29/2021 13:10:17	Mindy Hardy	Mindyhardy@gmail.com	510 Dutch Summit Ct, Midway UT 84049	Yes	Very much in favor of the art center!
63	3/29/2021 13:10:17	Stan Beagley	stanbeagley@gmail.com	417 W. 1120 S. Midway Ut 84049	Yes	
64	3/29/2021 13:10:31	Aja Mills	amills.4@hotmail.com	579 N Center St, Midway, UT 84049	Yes	
65	3/29/2021 13:12:41	Preston Phillips	amills.4@hotmail.com	579 N Center St, Midway, UT 84049	Yes	
66	3/29/2021 13:22:31	Shery Greenwell	shery.greenwell@yahoo.com	1135 Dutch Fields Pkwy., Midway UT 84049	Yes	
67	3/29/2021 14:00:15	Justin A. Roylance	justin.roylance@homevestors.co	640 Pine Canyon Rd. Midway, UT 84049	Yes	

	TIME STAMP	NAME	EMAIL ADDRESS	ADDRESS	MIDWAY VOTER	COMMENTS
68	3/29/2021 14:00:15	Linda Bruderer	linda.bruderer@yahoo.com	905 S Farrell Fam Circle	Yes	
69	3/29/2021 14:00:49	Katie Baird	katiebaird@gmail.com	791 Michie Ln, Midway, UT 84049	Yes	Thank you for supporting the arts in our community, and for working to preserve walking trails and green space for all residents!
70	3/29/2021 14:31:28	Claire Osbome	claireutah@gmail.com	PO Box 474, Midway, UT 84049	Yes	An art center would provide SO much to our community, including long-term revenue, which would be WAY better than a bunch of houses. Thanks!
71	3/29/2021 14:31:54	Mason Osbome	mosbome211@gmail.com	PO Box 474, Midway, UT 84049	Yes	
72	3/29/2021 14:54:58	Melanie Berrett	melanie@melaniewberrett.com	540 Craftsman Way	Yes	I know that the MAC will stay true to the values of Midway residents while providing an opportunity for the growth and development of our community at large. We cannot afford not to build this art center. The benefits both socially and economically are exponential and should not be overlooked. Please approve as soon as possible!
73	3/29/2021 15:07:57	Dana Del Francia	dana@danadel.com	722 N 804 W. Midway, UT 84049	Yes	
74	3/29/2021 15:07:57	Deanna Bunnell	deannabunnell@gmail.com	88 W 350 S	Yes	
75	3/29/2021 17:06:03	Eliza Roylance	Elizaroylance@gmail.com	640 Pine Canyon rd	Yes	
76	3/29/2021 17:06:03	Lorenzo Willis	enzomwillis@gmail.com	1053 N Meadow Creek Way	Yes	
77	3/29/2021 17:08:47	Autumn M. Iverson	autumniverson@gmail.com	503 S 300 E, Midway, UT 84049	Yes	
78	3/29/2021 17:18:21	Erin Malan	erin.malan@gmail.com	1295 Canyon View Rd, Midway, UT 84049	Yes	
79	3/29/2021 17:25:13	Jared Malan	jfals82@gmail.com	1295 Canyon View Rd., Midway, UT 84049	Yes	We need more commercial space on Mainstreet
80	3/29/2021 18:08:11	Steven Hardy	shardy58@comcast.net	197 W Fam Springs Ln, Midway, UT 84049	Yes	Plan B is a much more appealing plan, keeps the majesty of Memorial Hill prominent as it should be.
81	3/29/2021 18:11:02	KLynn Lochhead	kllochhead@gmail.com	477 Craftsman Way Midway	Yes	Thank you for your wonderful service to Midway!
82	3/29/2021 18:11:02	Matthew Magleby	matthewmagleby@gmail.com	1001 s cascade falls Cir Midway Utah 84049	Yes	We definitely want the MAC at the base of memorial hill!!!!
83	3/29/2021 20:00:15	James Johnson	Crazycanuck131@yahoo.com	496 S 360 E	Yes	
84	3/29/2021 21:57:10	Michael Weilenmann	mikeweilenmann@msn.com	8 East Village Circle Midway UT 84049	Yes	The arts should be a priority in our community
85	3/29/2021 21:57:10	Sarah Christensen	Smartin3435@hotmail.com	816 pine canyon rd	Yes	
86	3/29/2021 22:07:07	Jacob Jones	5226257@gmail.com	108 W 200 N	Yes	
87	3/29/2021 22:07:07	Kevin Allan	allankevin@bellsouth.net	73 E 450 S midway Utah 84049	Yes	
88	3/29/2021 22:31:00	Mark Nelson	mark@realrunners.com	326Alpinhof Lane	Yes	
89	3/29/2021 22:31:00	Pierrette Tiemey	ptiemey7379@gmail.com	1001 S Cascade Falls Cir Midway UT 84049	Yes	We love the theater and feel like the MAC will set Midway apart.
90	3/29/2021 22:37:09	Shanna Nelson	Shanna@realrunners.com	326 Alpinhof In. midway Utah	Yes	Would love to see an art center in Midway!
91	3/29/2021 22:50:59	Larry Kendrick	Larrykendrick@icloud.com	1237 West Lime Canyon Way	Yes	
92	3/29/2021 22:50:59	Marci Heugly	Mjheugly@hotmail.com	596 Bayhill Drive	Yes	Yes, I support the building of the Midway Arts Center theater. The MAC will preserve Memorial Hill and green space in downtown Midway and should be approved by the City Council as soon as possible.
93	3/29/2021 22:52:25	London Kendrick	Londonkendrick@cloud.com	1237 West Lime Canyon Way	Yes	
94	3/29/2021 22:52:25	Nancy Van Alostine	nancydanvan@hotmail.com	1342 Montaban Way, Midway, UT 84049	Yes	
95	3/29/2021 22:54:03	Jace Kendrick	Jacekendrick@icloud.com	1237 West Lime Canyon Way	Yes	
96	3/29/2021 22:54:03	Jolena Childs	jolenachilds@gmail.com	1159 W.lime canyon, Midway, Utah 84049	Yes	
97	3/29/2021 22:55:54	Sherron Kendrick	Sherronkendrick@mac.com	1237 West Lime Canyon Way - Midway	Yes	

	TIME STAMP	NAME	EMAIL ADDRESS	ADDRESS	MIDWAY VOTER	COMMENTS
98	3/30/2021 7:51:57	Camie Hardy	camiehardy@msn.com	197 W Farn Springs Ln, Midway, UT 84049	Yes	This will allow all of Midway to keep the view to Memorial Hill, adding to our sense of community, and will bring the arts more fully to Midway.
99	3/30/2021 8:07:59	Charles Gunn	ckgunn@gmail.com	788 N. Double Eagle Dr, Midway, UT 84049	Yes	I believe the Midway Arts Center would benefit all residents of our lovely city.
100	3/30/2021 8:07:59	Timothy Jarvell	cetan7405@gmail.com	3565 E. Center Road	yes	MAC please! More arts!
101	3/30/2021 8:11:46	Cheryl Beagley	cherylbeagley@gmail.com	417 W 1120 S Midway UT 84049	Yes	Love the plays!
102	3/30/2021 8:11:46	Kathie Gunn	ckgunn@gmail.com	788 N. Double Eagle Dr., Midway, UT 84049	Yes	I believe the Midway Arts Center would benefit all residents of our lovely city.
103	3/30/2021 8:20:11	Moiria Wright	mwrightime@verizon.net	274 w lady bank ln midway	Yes	
104	3/30/2021 8:20:11	Tamara Battles	Tbattles27@gmail.com	1202 Dutch Fields Pkwy Midway, Utah 84049	Yes	
105	3/30/2021 8:32:20	Ellen Eckersley	Elleneck1@yahoo.com	1475 S Tate Ct. Midway UT 84049	Yes	
106	3/30/2021 8:32:20	Tawnee	Garickt2019@gmail.com	P.O. Box 127 midway Utah , 84049	Yes	
107	3/30/2021 8:45:44	Cheryl Felsted	Cherylfelsted@gmail.com	38 N 100 W, Midway, UT 84049	Yes	We love what you bring to this town in the form of theater arts. Thank you.
108	3/30/2021 8:45:44	Colleen Bonner	colleenbonner@msn.com	160 South Center St.	Yes	
109	3/30/2021 9:17:14	Emma Heugly	emmaheugly@hotmail.com	596 Bayhill Drive	Yes	
110	3/30/2021 9:17:14	William A Woolf	Drbill@woolf.com	759 Double Eagle Drive	Yes	
111	3/30/2021 9:41:45	Marie Cooper	tigerbutter75@yahoo.com	123 E 100 N Midway UT 84049	Yes	An Arts center will be Benefit our local residents and businesses as well as attracting visitors. More successful businesses will keep our property taxes down, especially beneficial for our long-term residents. And everybody can agree on the need for more dedicated green space. Please consider the positive impacts this project will have on our growing community.
112	3/30/2021 11:24:31	Dennis potter	dpotterx@gmail.com	333 east 300 north	Yes	Keep us rural
113	3/30/2021 11:24:31	Diane Woolf	dianed@woolf.com	759 Double Eagle Drive	Yes	
114	3/30/2021 13:34:39	Tasha Groesbeck	Tgbeck@hotmail.com	1263 W Lime Canyon Rd	Yes	My family and I have really enjoyed participating in and watching High Valley Arts productions ever since we moved to the valley.
115	3/30/2021 15:11:04	Brent Crittenden	bcritten@gmail.com	52 W Farn Springs Lane	Yes	If I had to choose between this and the arts center being promoted by the Heber City group, I would pick this without a doubt. And, it appears that one or both will happen. In the near term, I do not expect this to bring in visitors from outside the community other than friends and relatives of the performers. The main reasons I support this is that this group is not seeking taxpayer support to maintain their program. The Heber City group is looking for initial funding plus ongoing taxpayer assistance through taxes such as a property tax levy or a sales tax or both. Thank you (Mayor and City Council) for the hard work that you do. Regards, Brent Crittenden
116	3/30/2021 15:11:04	Jamie Giordano	athenablaz@gmail.com	3565 E. Center Road	yes	Please build MAC instead of more commercial buildings on MainStreet Midway
117	3/30/2021 16:45:44	Jane Carson	jane_j_carson@msn.com	788 N 50 W, Midway, UT 84049	Yes	
118	3/30/2021 16:45:44	Katie Studdert	katiestuddert@gmail.com	284 S 300 E, Midway, UT 84049	Yes	

	TIME STAMP	NAME	EMAIL ADDRESS	ADDRESS	MIDWAY VOTER	COMMENTS
119	3/30/2021 19:32:32	Kristen Sorensen	Kristensorensen@gmail.com	20 e 450 s, Midway, Utah 84049	Yes	Please preserve open space in front of Memorial Hill and build a European village and Midway Arts Center for the community to use!
120	3/30/2021 19:32:32	Laraine Z Jones	jupiteraine@gmail.com	108 W 200 N Midway, UT 84049	Yes	
121	3/30/2021 20:05:41	Janice Kennedy	bonanza7947k@gmail.com	898 E Hamlet Circle S, Midway UT 84049	Yes	I have been waiting for a long time for this. It will be good for Midway residents now, and in the future, while preserving our history and traditions.
122	3/30/2021 20:07:30	Marilyn Crittenden	Marilyncrittenden@gmail.com	52 W Fam Springs Rd Midway Utah 84049	Yes	
123	3/30/2021 20:07:30	Megan Olsen	Olsen.n.megan@gmail.com	1290 windmill ln	Yes	
124	3/30/2021 20:13:54	Isaac Robertson	Randmorty4@gmail.com	2737 Water Wheel Ct	Yes	
125	3/30/2021 20:13:54	Max Willis	maxwillis@msn.com	1053 N Meadow Creek Way, Midway, UT 84049	Yes	We live the arts and need to support High Valley Arts who does so much to enrich our community.
126	3/30/2021 20:16:16	Chris Miller	chrismiller0@gmail.com	1128 Dutch Fields Pkwy	Yes	
127	3/30/2021 20:16:16	Craig Bumham	craigburnham46@gmail.com	1205 N Cottage Way, Midway, Ut 84049	Yes	Good idea
128	3/30/2021 23:06:50	Cami Bingham	cami.livewell@gmail.com	396 E. 500 S., Midway, UT 84049	Yes	
129	3/30/2021 23:07:27	Alan Bingham	alan.livewell@gmail.com	396 E. 500 S., Midway, UT 84049	Yes	
130	3/30/2021 23:09:34	Gordon Lambert	midwaylamberts@yahoo.com	840 Double Eagle Dr Midway, UT 84049	Yes	
131	3/30/2021 23:09:34	Tim Rock	skirocksurf@yahoo.com	1345 west 365 north	Yes	Keep Midway green and rural!
132	3/30/2021 23:11:16	Jacquelyn Lambert	midwaylamberts@gmail.com	840 Double Eagle Dr Midway, UT 84049	Yes	
133	3/31/2021 20:11:02	David Ferranti	dm4anti@hotmail.com	842 Michie Ln, Midway Utah	Yes	Plan B
134	3/31/2021 20:11:02	Debbie Foreman	dforeman_whipple@icloud.com	1080 Warm Springs Road. Midway 84049	Yes	
135	4/1/2021 5:58:44	Warren Rohrer	Warren.Rohrer44@gmail.com	PO Box 648, Midway	Yes	Please approve the MAC plan
136	4/1/2021 8:41:20	Christian Duncan	nkuludunc@gmail.com	PO Box 104	Yes	
137	4/1/2021 8:41:20	Margo Schick	margo.schick@gmail.com	PO Box 936 Midway Utah 84049	Yes	
138	4/1/2021 9:03:26	Danielle De Jong	Englehomd@gmail.com	PO Box 1314, Midway, UT 84049	Yes	
141	4/1/2021 9:07:09	Jon Fisher	Fishfam487@gmail.com	506 Mission Dr	Yes	Option Plan B
142	4/1/2021 9:56:02	Bill Pekny	Nancybillp@msn.com	93 W. Innsbruck Lane	Yes	Hi Sue. We support you to the max. Bill
143	4/1/2021 9:56:02	Tim Cowell	tcowell93@gmail.com	426 Fox Den Rd. Midway UT 84049	Yes	
144	4/1/2021 9:57:28	Nancy Pekny	Nancypekny@me.com	93 W. Innsbruck Lane	Yes	
145	4/1/2021 9:57:28	Teri Pena	teri.pena@gmail.com	360 Anna Lane	Yes	
146	4/1/2021 10:46:06	Russ Watts	Russ@wattsentprises.com	611 Dutch Mountain Dr. , Midway Utah	Yes	We support the art center being built in Midway !!
147	4/1/2021 10:50:20	Rulon L. Tate	montyt@alumaline.net	800 Double Eagle Drive	Yes	Totally support
148	4/1/2021 10:50:20	Susan Magoffin	susanmagoffin47@gmail.com	PO Box 747 midway Utah 84049	Yes	I support the M•A•C and the beautiful shops and grounds landscaped like a park to keep Midway it' s charming self.
149	4/1/2021 11:07:41	Kaylma Rohrer	kaylma.rohrer@gmail.com	P.O. Box 648 Midway, Utah 84049	Yes	
150	4/1/2021 11:07:41	Stephanie Winzeler	malloyprints@gmail.com	1210 N Dutch Highland Dr. Midway, Ut	Yes	
151	4/1/2021 11:20:20	Hilma Bellessa	hilma@mac.com	625 N Homestead Dr., Midway, UT 84049	Yes	I support this.
152	4/1/2021 11:20:20	Jennifer Emory	jennifer.emory@gmail.com	910 Dutch View Ct Midway UT 84049	Yes	Would love to see the MAC
153	4/1/2021 11:21:14	Lawrence E. Corbridge	prescorbridge@yahoo.com	1212 W Lime Canyon Way, Midway UT	Yes	This will be a significant contribution and asset to Midway.
154	4/1/2021 11:33:15	Jacquelyn Corbridge	jscorbridge@yahoo.com	1212 W Lime Canyon Way, Midway UT	Yes	An arts center as planned will be a wonderful contribution to the community of Midway and Heber Valley.
155	4/1/2021 11:33:15	Karilyn Preston	Kemoore8181@gmail.com	19 W Village Circle	Yes	
156	4/1/2021 11:35:08	Michael Teig	mteig11@me.com	1353 N Montreux Dr., Midway, Utah 84049	Yes	

	TIME STAMP	NAME	EMAIL ADDRESS	ADDRESS	MIDWAY VOTER	COMMENTS
157	4/1/2021 11:35:08	Tara Stafford	taramstafford@yahoo.com	75 S 550 E Midway	Yes	I live within close proximity and also own Growing Light Montessori school (across Main Street from this development) and would like to voice my support for the MAC option if this space is going to be developed. Thank you for your consideration.
158	4/1/2021 12:21:23	Ken Tholstrom	kentholstrom@gmail.com	1350 Antibe Lane, Midway, UT 84049	Yes	I am 100% for this project!!!!
159	4/1/2021 12:21:23	Mary Schindeler	marycschindeler@gmail.com	466 silver fox road	Yes	
160	4/1/2021 13:46:15	David McMaster	macdlm@gmail.com	429 Meadow Creek Lane	Yes	Would love to see Midway take the lead on this rather than be absorbed into Heber City. The Performing Arts can be another distinctively positive thing we are known for in Midway. Also a reminder that this is only an indoor arts center, any outdoor theater would be located elsewhere.
161	4/1/2021 13:46:15	Vanessa Neal	nessaneal@gmail.com	235 creek place midway	Yes	
162	4/1/2021 13:51:24	Mindy McMaster	Melinda.mcmaster@gmail.com	429 meadowcreek lane	Yes	This venue seems to match Midway's historic identity. I am worried that our potentially charming main street will be lost if we don't carefully plan. The open space is key to me in supporting an art center at this location. please don't close the view corridor with buildings!! I also think our town needs something besides more houses!!
163	4/1/2021 13:51:24	Rebekah Mickelson	Rmick1011@gmail.com	PO Box 1258 Midway 84049	Yes	
164	4/1/2021 21:37:23	Stephani Whiting	stephaniwhiting@gmail.com	1116 N 455 W Unit 8, Midway, UT 84049	Yes	
165	4/1/2021 22:36:16	Sariah Stokes	Sariahstokes@gmail.com	1465 S 200 W, Midway UT 84049	Yes	We would love to support the MAC
166	4/2/2021 5:07:38	Rick Ward	rick.n.ward@gmail.com	1085 Links Dr., Midway, UT 84049	Yes	We love live theater, and High Valley Arts brings outstanding theater to this great community. We have attended just about every production since moving here.
167	4/2/2021 5:08:26	Marianne Ward	mareandrick1@gmail.com	1085 Links Dr., Midway, UT 84049	Yes	
168	4/2/2021 5:18:28	John "Jake" Emmett	jdemmett@gmail.com	984 Uri Lane #2, Midway, UT 84049	Yes	
169	4/2/2021 5:19:24	James Galbraith	jamesanddixie@msn.com	76 E Versailles Way, Midway, UT 84049	Yes	
170	4/2/2021 6:05:40	Heather Allison	hallisonsmith11@gmail.com	1266 Links Dr	Yes	
171	4/2/2021 6:28:08	Camille Hillam	camillehillam@gmail.com	PO Box 1085	Yes	
172	4/2/2021 6:32:19	Leonard Wilkerson	Leonardbwilkerson@gmail.com	461 W 970 S, Midway, UT, 84049	Yes	
173	4/2/2021 6:37:27	Christopher Clason	Clason.chris@gmail.com	908 Michie Lane	Yes	Please make this happen. The power poles are bad enough. We allowed that to happen. Let's figure this one out on our own.
174	4/2/2021 6:42:31	Wendy Stirland	kreywendy@yahoo.com	1504 N Chancey Lane Midway UT 84049	Yes	
175	4/2/2021 6:55:03	Annette Velarde	annettevelarde@mac.com	7240 N. Greenfield Dr, Park City. 84098	Yes	
176	4/2/2021 7:05:39	Cordell Esplin	Cesplin@me.com	1059 West Lime Csnyon Road	Yes	I totally support this project
177	4/2/2021 7:06:39	Linda Esplin	Esplinlin@mac.com	1059 West Lime Canyon Road	Yes	

	TIME STAMP	NAME	EMAIL ADDRESS	ADDRESS	MIDWAY VOTER	COMMENTS
						I strongly support MCA being in Midway and I think this is a great site. All parties might consider another site plan that may have a greater benefit for the community and for the Arts Center. I encourage the City and MCA to consider an option C site plan. 'Option C should have the MCA at front of property along Main street with parking and residential development between MCA and Memorial Hill. The MCA next to Main Street would contribute to the character, vitality and continuity of Main Street. I realize that Memorial Hill can be a good backdrop for outdoor performances, but I assume this will be a facility in use year round. Don't underestimate the value of street presence of the MCA building being front and center in the Midway community fabric. Again I voice my support of the MCA being in Midway and this is an excellent location for the performance arts center whatever the site plan.
178	4/2/2021 7:07:33	Robert Tippets	rtippets@gmail.com	811 Double Eagle Drive, Midway, UT 84049	Yes	
179	4/2/2021 7:33:15	Lori Sheehan	Lorilie3@aol.com	606 S. Appenzell Ln.	Yes	YES, please!
180	4/2/2021 7:36:44	Ashley Bowen	ashleybowen1@gmail.com	451 S 300 E	Yes	
181	4/2/2021 7:45:50	Mickey Oksner	micksmeister@earthlink.net	PO Box 459	Yes	When I was on the Midway Planning Commission I argued/supported this very concept to rezone that parcel as a tourism zone. Stu Waldrup will remember this effort. I'm in.
182	4/2/2021 7:59:25	Leslie Martin	martinlv555@gmail.com	920 Martha Lane	Yes	
183	4/2/2021 8:04:02	Mary Davis	Csjjkrdavis@hotmail.com	1080 South Clearwater Way Midway, Utah. 84049	Yes	Very excited to have this center in Midway!
184	4/2/2021 8:08:38	Sara Hansen	sjcollings@hotmail.com	846 n Swiss farm court	Yes	
185	4/2/2021 8:16:12	Ron Parker	rparker@aol.com	PO BOX 1266 MIDWAY UT 84049	Yes	We are all better off with the refining influence of music, theater & the arts in general.
186	4/2/2021 8:19:16	Richard K. Gallagher	dickgallagher1976@gmail.com	140 Valais Pkwy, Midway 84049	Yes	
187	4/2/2021 8:19:26	Tatum Buhl	Tatumrenee144@yahoo.com	880 stringtown road	Yes	We love the outdoor theatre... the first show we saw was Cinderella and my kids still talk about it!
188	4/2/2021 8:23:26	Sharon Sanderd	Sharisanders624@hotmail.com	1366 Montaban Way Midway, Utah 84049	Yes	
189	4/2/2021 8:24:14	Connie Hamis	H3connieh@gmail.com	983 W. Grindelwald Lane 4	Yes	
190	4/2/2021 8:26:32	Brooke Watters	bross@parkcity.org	369 Bowden Circle, Midway UT 84049	Yes	
191	4/2/2021 8:29:39	Janis Pierce	pierce.janis@gmail.com	P O Box 906, Midway, UT 84049	Yes	We need this Art Center to house our flourishing arts and the creative artists that call Midway home!
192	4/2/2021 8:31:21	Margery Clark	mclark1944@gmail.com	452 Fairway Drive	Yes	
193	4/2/2021 8:32:31	David Cannon	dcannon28@icloud.com	644 S 100 W Heber, UT	Yes	
194	4/2/2021 8:37:03	Lezlie Evans	lezlieevans@gmail.com	1097 Homestead drive	Yes	We love the arts and the richness and unity that MAC would bring to the Heber/Midway valley. We would like to see more space dedicated to making the arts a part of our community!
195	4/2/2021 8:39:15	Stephanie Richardson	Bobamajs@aol.com	430 Fairway Dr	Yes	
196	4/2/2021 8:45:15	Sandy Ross	Sandyross412@gmail.com	447 Fairway Drive. Midway Utah 84049	Yes	
197	4/2/2021 8:54:03	Cheryl Fox	cheryl_fx@yahoo.com	1268 canyon view rd. midway.	Yes	
198	4/2/2021 8:59:50	Nancy O'Toole	Otoolenancyti@gmail.com	273 S 250 W midway	Yes	I will support you anyway ican

	TIME STAMP	NAME	EMAIL ADDRESS	ADDRESS	MIDWAY VOTER	COMMENTS
199	4/2/2021 8:59:56	L. Colleen Avey	cmumav1@gmail.com	1030 Oberland Dr. Unit #5Midway, UT 84049	Yes	Love having High Valley Arts in our city, it is a wonderful enrichment to our community!
200	4/2/2021 9:32:49	Courtney Archibald	courtney.archibald@gmail.com	187 E 600 N Midway, UT 84049	Yes	
201	4/2/2021 11:52:30	Barbara Haymore	db.haymore@comcast.net	1052 Tumbery Court	Yes	
202	4/2/2021 12:42:08	Tim Martin	martintim078@gmail.com	920 Martha Lane Midway UT 84049	Yes	
203	4/2/2021 15:04:17	Harry Weyandt	Harryweyandt@hotmail.com	190 E Main St	Yes	We need this in our community.
204	4/2/2021 15:15:45	Richard Moore	richardmoore3@cox.net	66 W Fam Road, Midway, Utah 84049	Yes	An Arts Center would be a great addition to our Community and to the State of Utah
205	4/2/2021 15:16:43	Jean Moore	mjeanrick77@reagan.com	66 W Fam Road, Midway, Utah 84049	Yes	
206	4/2/2021 15:17:16	Kate Davis	Katebemice@gmail.com	526 west cascade meadows loop, midway ut 84049	Yes	
207	4/2/2021 15:45:11	Claudia Tholstrom	Ctholstrom@comcast.net	1350 Antibe Ln, Midway, UT 84049	Yes	100% for this project!!!
208	4/2/2021 15:45:11	Dawn Seare	Dawnseare@hotmail.com	384 Tanner Lane	Yes	Our town would greatly benefit from have a theater center. I have children who have been performing with high valley arts for the past several years and the experience has been so great for their self esteem and confidence. Please bring the Mac to midway!
209	4/2/2021 15:52:03	Margaret Fugitt	Maf12mch@aol.com	874 Dutch Ct, Midway UT 84049	Yes	What a wonderful addition this would be to our community. I am totally in favor!
210	4/2/2021 15:59:19	Karen Reed	007kmreed@gmail.com	473N 680W Midway Utah 84049	Yes	
211	4/2/2021 15:59:19	Robert J. Fugitt	UTAHJIM@AOL.COM	874 DUTCH CT, MIDWAY UT 84049	Yes	
212	4/2/2021 17:33:27	Melyne Fritze	Minfritze@hotmail.com	575 w 200 n Midway, UT	Yes	
213	4/2/2021 20:18:31	Elizabeth Crittenden	crittenden.elizabeth@gmail.com	99 W Fam Springs Rd	Yes	
214	4/3/2021 8:38:39	Elizabeth Zaccardi	lizzyzaccardi@icloud.com	1615 east 1050 north Heber	Yes	This will be a much needed change.
215	4/3/2021 8:42:14	Pete Zaccardi		1615 east 1050 north Heber	Yes	The current zoning will shadow what so many people respect in Midway.
216	4/3/2021 9:09:14	Les Emmett	lesaemmett@gmail.com	984 Uri Lane #2, Midway, UT 84049	Yes	Our children and grandchildren are actively involved in the local arts community. This would be a wonderful addition!
217	4/4/2021 15:03:16	Cass C. Ho	Cassieho@aol.com	988 North 100 West	Yes	
218	4/4/2021 17:55:45	Christy Brown	christybrown3@yahoo.com	525 W 200 N, Midway, UT 84049	Yes	Looks like a great use of space. Plus, I would enjoy watching the plays.
219	4/4/2021 19:03:19	Mary Eckersley	meckersley58@gmail.com	1475 s Tate court	Yes	The need has never been greater for a center like this. Perfect place and opportunity to provide a useful arts center and beautify the inevitable development of this property.
220	4/5/2021 8:01:18	Melissa Jones	melissa.queenbee@gmail.com	1010 Lacy Lane	Yes	
221	4/5/2021 12:31:43	Janel Hoggan	janedaze@hotmail.com	281 Alpinhof Circle Midway, UT 84049	Yes	
222	4/5/2021 12:32:16	Bryan Hoggan	bhoggan@hotmail.com	281 Alpinhof Circle Midway, UT 84049	Yes	
223	4/5/2021 15:13:54	Michael Fairclough	michaelf605@gmail.com	1444 S 200 W, Midway UT 84049	Yes	We fully support the ideas of a Midway Arts Center
224	4/5/2021 21:24:21	Lorraine Branham	ldlbranham@gmail.com	PO Box 1120, Midway, UT 84049	Yes	Please consider this important blessing to our community
225	4/5/2021 21:24:21	Vickie Weyandt	momweyandt@hotmail.com	190 E. Main St. Midway, UT 84049	Yes	
226	4/5/2021 22:23:57	Mimi Murdock	MimiMurdock@gmail.com	P O Box 1012 Midway, UT 84049	Yes	This planned development will enhance our beautiful Midway.
227	4/5/2021 22:26:14	George Murdock	GTMmail@gmail.com	P O Box 1012 Midway, UT 84049	Yes	Growth is coming so lets support this kind of positive progress for local theater!
228	4/6/2021 8:54:46	Laurie Fitzgerald	Midwayfitz@gmail.com	578 S Appenzell lane	Yes	

	TIME STAMP	NAME	EMAIL ADDRESS	ADDRESS	MIDWAY VOTER	COMMENTS
229	4/6/2021 8:54:46	Robert Magoffin	RobMagoffin@gmail.com	P.O. Box 747 Midway Utah 84049	Yes	
230	4/6/2021 11:03:58	Rich Cliften	richcliften@gmail.com	372 Fox Den Rd. Midway, ut	Yes	
231	4/6/2021 11:03:58	Stacee McCotter	mccotterclan@gmail.com	PO Box 1163 Midway UT 84049	Yes	
232	4/6/2021 11:07:38	Tate McCotter	popsicleman@gmail.com	PO Box 1163 Midway UT 84049	Yes	
233	4/6/2021 11:07:38	Valine Quinn	valinequinn@gmail.com	1431 s Tate ct	Yes	
234	4/6/2021 21:13:59	David Carson	David_G_Carson@msn.com	788 N 50 W, Midway, UT 84049	Yes	SEE COMMENTS, END
235	4/6/2021 21:13:59	Debi Kennedy	Debimtb@mac.com	480 mission dr.	Yes	I want option B
236	4/7/2021 6:24:14	Ashley Taylor	Ashley.k.barber@gmail.com	862 e Hamlet Circle s Midway UT 84049	Yes	
237	4/7/2021 6:39:03	Janice Nelson	Janice.Nelson@imail.org	73 Versailles Way Midway, UT 84049	Yes	We love the arts. We support all they do.
238	4/7/2021 6:43:59	Andrea Scott	Dreyscott@gmail.com	583 East Dutch Ridge Court Midway, Utah 84049	Yes	
239	4/7/2021 7:06:13	Barbara Ream	ream.barbara@gmail.com	433 E Saddle Dr, Midway, UT	Yes	High Valley Arts makes a very important cultural contribution to the City. We have enough high density developments in our community, and this project preserves the character of the town,
240	4/7/2021 7:40:32	Heather Whitney	hwhitney_90403@yahoo.com	745 Dutch Valley Dr., Midway, UT 84049	Yes	I feel this will add to the resort appeal and amenities of our town Midway, which relies heavily on resort-related taxes and associated sales in order to operate successfully.
241	4/7/2021 8:19:25	Paige Forheringham	paiger83@gmail.com	330 East Bowden Circle, Midway UT 84049	Yes	
242	4/7/2021 8:39:33	Christine Caldwell	christinecaldwell@msn.com	PO Box 760, Midway, Utah 84049	Yes	
243	4/7/2021 8:39:45	York Fitzgerald	YorkFitz@gmail.com	578 S Appenzell Ln	Yes	
244	4/7/2021 8:55:05	Pamela Clark	neeelmanpamela@gmail.com	650 S 650 E Heber, utah 84032	Yes	Registered to vote in Heber.
245	4/7/2021 8:55:59	Gary Neeleman	garyneeleman@aol.com	8827 Altair Dr Sandy UT 84093	Yes	Registered for Sandy
246	4/7/2021 9:19:05	Caren Mostert	carenba@earthlink.net	859 Dutch Court, Midway, Ut 84049	Yes	
247	4/7/2021 9:27:33	Mike Baird	mikeabaird@gmail.com	791 Michie Lane, Midway 84049	Yes	This is a great idea. We need to support the arts in Midway and preserve the open views too.
248	4/7/2021 11:29:58	Pat Sadler	grammapoohpat@gmail.com	1380 N Bird Drive Midway Utah	Yes	
249	4/7/2021 12:17:01	Dan Iverson	danoiverson@gmail.com	503 S 300 E, Midway, UT 84049	Yes	
250	4/7/2021 14:38:44	Pam Weilenmann	Playapamela@hotmail.com	8 E. Village Cir	Yes	One of the most important benefits that our community can boast is that there are creative, outstanding offerings in the arts , made possible by years of locals who put in hard work to establish them here in this to tiny town.
251	4/7/2021 15:54:37	Benjamin Iverson	benjamin.c.iverson@gmail.com	276 Fox Den Road, Midway, UT 84049	Yes	
252	4/7/2021 16:39:00	Dave Mickelson	Dmickelson.flhx@gmail.com	PO Box 834, Midway Utah 84049	Yes	Yes. I support this.
253	4/7/2021 21:41:53	Kenneth Ross	kenrossesq@gmail.com	447 Fairway Dr., Midway, UT 84049	Yes	
254	4/8/2021 1:39:17	Chelsea Strong	Chelsea@talpinesconstruction.c	96 N 100 W Midway UT 84049	Yes	
255	4/8/2021 6:55:55	Andy Bown	utbown@msn.com	PO Box 105	Yes	
256	4/8/2021 6:57:06	Naomi Bown	Naibown@gmail.com	PO Box 105	Yes	
257	4/8/2021 17:28:50	Martin Van Roosendaal	mlvii7373@gmail.com	P.O. Box 6	Yes	
258	4/8/2021 17:29:16	Annalee Van Roosendaal	anavan65@yahoo.com	P.O. Box 6	Yes	
259	4/8/2021 18:27:04	Shelbi Kohler	shelbilkohler@gmail.com	13 E 450 S midway ut	Yes	
260	4/8/2021 21:39:34	Meredith Lee	brettandmer@yahoo.com	351 Alpinhof Lane, Midway, UT 84049	Yes	
261	4/8/2021 21:53:21	Brett Lee	brettlee1@gmail.com	351 Alpinhof Lane, Midway, Utah 84049	Yes	We are so excited to have the arts center finally become a reality!
262	4/9/2021 9:50:08	Josef Heugly	joeheugly@hotmail.com	596 Bayhill Dr, Midway UT 84049	Yes	Please, we need the Midway Arts Center!
263	4/9/2021 13:45:40	Megan Baird	meganlbaird@gmail.com	791 Michie Ln Midway UT	Yes	

	TIME STAMP	NAME	EMAIL ADDRESS	ADDRESS	MIDWAY VOTER	COMMENTS
264	4/10/2021 8:58:09	Tyler Dow	td@tylerrdow.com	900 Michie	Yes	Open and commercial mixed use with arts... well designed open space.
265	4/10/2021 9:44:59	Marlene Szoczek	4luvdud@gmail.com	834 Michie Lane	Yes	
266	4/10/2021 12:52:40	Jill Trimble	jtrimble@sonic.net	376 E. 340 S.	Yes	This would be a welcome and enjoyable addition to our town.
267	4/12/2021 9:14:22	Meredith Hendricks	mere925@gmail.com	132 Meadow Lane Midway, UT 84049	Yes	
268	4/12/2021 20:01:04	Tricia Cope	triciacope@gmail.com	500 Mission Dr Midway	Yes	
269	4/13/2021 13:30:29	Juliana Smith	julianajsmith@gmail.com	53 W 300 S	Yes	
270	4/13/2021 13:30:29	Kim Cliften	kimcliften@gmail.com	372 Fox Den Rd Midway UT 84049	Yes	This would absolutely add so much charm to Midway to have the MAC and European village. I grew up close to the Sun Valley area and am well acquainted with Leavenworth, Washington as well. This would bring so much value to our town and continue to make it a desired place to visit and live. Please consider changing the zoning. We want the commercial growth to enhance our town, not cover it up. Set it against Memorial Hill. It will be stunning. Thank you!
271	4/13/2021 14:11:14	Lyle Gertsch	lyleandnola@gmail.com	306 Pine Canyon Road	Yes	This option is more visible pleasing than townhouses clear to the road
272	4/16/2021 8:22:56	Keith and Launa Barney	gogranny816@gmail.com	1025 West Swiss Alpine Rd, Midway Utah 84049	Yes	
273	4/16/2021 22:26:10	Scott Cannon	scottscannon@gmail.com	440 E Saddle Dr, Midway, UT 84049	Yes	
274	4/16/2021 22:32:38	Karee Cannon	kareecannon@gmail.com	440 E. Saddle Drive Midway Utah 84049	Yes	
275	4/20/21 16:45	Jerry Owens	Jeryleeowens@gmail.com	79 N Johnson Mill Rd	Yes	
276	4/23/2021 13:45:12	Dennis Goudy	Dennis.goudy@uvu.edu	397 Cottage Creek Court Midway, Utah	Yes	
277	4/24/21 19:42	Tricia	triciacope@gmail.com	500 Mission Dr	Yes	
278	4/25/21 9:47	Cody Gamangasso	codygammo@gmail.com	873 N. Harvest Lane	Yes	Keep Midway Special
279	4/26/21 10:26	Paul Taylor	Inclinecos@yahoo.com	1270 pine canyon road, Midway UT 84049	Yes	
280	4/26/21 19:30	Sheila Agnew	sheilaopa@gmail.com	1406 North Chancey Lane	Yes	Plan B
281	4/27/2021 1:18:41	Cheryl A. McCullough	cheryl.mccullough@me.com	PO BOX 758 MIDWAY UT 84049	Yes	
282	5/3/21 19:41	Susette Gertsch	ut_artpro@mac.com	850 Homestead Dr	Yes	I heartily endorse the Midway Arts Center to be built. This will be a great source of cultural enhancement and a legacy to the rich and diverse arts of our community.
283	5/9/21 22:56	Sara Lafkas	smlafkas@gmail.com	512 N Farmhouse Way	Yes	
284	5/13/21 7:28	Lyndsey Locke	Locketj@gmail.com	542 N Meriwether Way Midway UT 84049	Yes	Hate to see it developed but will take more open space and lower density over the alternative
285	5/13/21 8:35	Melissa Giles	melissacgiles@gmail.com	565 Dutch Summit Ct	Yes	
286	5/22/21 11:03	William Charles		1330 Dutch Highland Drive, Midway, Utah 84049	Yes	Midway Arts Center would be an amazing and needed addition for the community
287	5/22/21 11:26	Erin Haris		915 Dutch View Ct Midway UT 84049	Yes	
288	5/22/21 15:13	Maggie stevens		416 E 500 S	Yes	Love the size and the architecture on the European style village. It fits!
289	5/22/21 15:15	Gary stevens		416 E 500 S midway 84049	Yes	Prefer the size of the euro style over the MCC's plan
290	5/22/21 16:43	David Adams		1041 S Mont Blanc Ct, Midway	Yes	
291	5/22/21 17:06	Janet Piepmeyer		141 Burgundy Lane Midway Utah 84049	Yes	
292	5/22/21 17:41	Steve Cooper		613 S Fox Den Rd, Midway UT 84049	Yes	

	TIME STAMP	NAME	EMAIL ADDRESS	ADDRESS	MIDWAY VOTER	COMMENTS
293	5/22/21 17:56	Kathleen Barlow		1112 N Springer View Loop. Midway	Yes	
294	5/22/21 17:57	Kirk Harris		915 Dutch View Ct.	Yes	
295	5/22/21 17:57	Tim Barlow		1112 N Springer View Loop. Midway	Yes	
296	5/22/21 18:18	Angie Dean		140 E Versailles Way	Yes	
297	5/22/21 18:20	Marsh Dean		140 E Versailles Way	Yes	
						I believe this would be a very beneficial use of donated land. The proposed design and architectural concept works to preserve the historic and style objectives of the unique Midway community. It also promotes a new and enhanced performance venue for local and regional talent to perform and entertain the broader Wasatch and Summit County community.
298	5/22/21 19:51	Lance Mehaffey		950 S Coldwater Way	Yes	
299	5/22/21 20:25	Amber Swedenborg		362 East Bowden Circle	Yes	
300	5/22/21 20:27	Jason swedenborg		362 E Bowden Circle	Yes	
301	5/23/21 7:45	Jeff Stroh		297 W Canyon View Ln, Midway, UT 84049	Yes	
302	5/23/21 9:00	Matthew Heimburger		156 W. Michie Lane, Midway, Utah 84049	Yes	What a great way to complement Midway's natural beauty, and keep the city vibrant and unique for generations to come!
303	5/23/21 9:01	Kate M. Fiddymnt		130 E Valais Pkwy	Yes	Let's do this right, for our community now, and for the future.
304	5/23/21 9:06	Gregg C. Fiddymnt		130 E. Valais Pkwy, Midway, UT 84049	Yes	
305	5/23/21 10:18	Jennifer Farmer		420 S. 360 E.	Yes	
306	5/23/21 10:18	Doug Farmer		420 S. 360 E.	Yes	
307	5/23/21 12:54	Douglas jones		508 south 300 east midway Utah 84049	Yes	
308	5/23/21 14:52	Charlotte Charles		1330 Dutch Highland Drive	Yes	Always yes to the Arts !
309	5/23/21 15:05	Joan Molina		1378 N Montreux Dr Midway UT 84049	Yes	Yes, I support the MAC
310	5/23/21 15:11	Sergio Molina		1378 N. Montreux Drive, Midway 84049	Yes	
311	5/23/21 15:12	Amelia Jones		508 s 300 e, midway, it 84049	Yes	
312	5/23/21 16:28	Michael baird		791 Michie lane midway Utah 84049	Yes	Would love having more arts in midway!!
313	5/23/21 17:15	Robert Stafford		75 E 550 E, Midway, UT 84049	Yes	
						I've been in commercial real estate for nearly 25 years. Let's move forward with MAC and create something special and preserve the real value in Midway.
314	5/23/21 18:13	Mark Haroldsen		845 West Cascade Cove, Midway, Utah 84049	Yes	
315	5/23/21 18:53	Jennifer Brown		1163 n springer view dr	Yes	I would love to have shops and an art center!
316	5/23/21 18:55	Chad Brown		1163 springer view dr	Yes	
317	5/23/21 20:03	Elise LeBlanc		395 S 360 E	Yes	
318	5/24/21 9:01	Naomi Cernyar		16 N Johnson Mill Rd, Midway UT 84049	Yes	This would be such a blessing and such an asset to the community if the MAC was built.
						This is an absolute no brainer! If something has to go onto that land the beauty of an arts center is much nicer than ugly flat row commercial development! Come on midway city council, we voted in a new mayor to put a stop to the awful decisions regarding preserving midways rural feel. Please do the right thing.
319	5/24/21 9:29	Alison Geake		910 S Center Street	Yes	
320	5/24/21 9:36	Abraham Geake		910 S Center St	Yes	Quality of life is more important than taxes
321	5/24/21 11:19	Margaret Culley		450 S. Silver Fox Rd. Midway Ut 84049	Yes	
322	5/24/21 11:21	Margo France		1084 N. Matterhom CT. Midway Ut 84049	Yes	

	TIME STAMP	NAME	EMAIL ADDRESS	ADDRESS	MIDWAY VOTER	COMMENTS
323	5/24/21 11:47	Elizabeth Roberts		866 E Hamlet Cir S Midway, UT	Yes	Please keep midway special 🙏❤️
324	5/24/21 12:09	Darcy Larson		970 s whitewater way midway ut 84049	Yes	
325	5/24/21 12:45	Boyd Llewelyn		888 S Whitewater Way midway, Utah 84049	Yes	
326	5/24/21 13:41	Lisa Willey		1204 Stringtown Road	Yes	Please make Midway a quality place to live. Let's not create another Alpine or Lehi
327	5/24/21 13:42	Todd Willey		1204 Stringtown Rd	Yes	
328	5/24/21 13:43	Preston Willey		1204 Stringtown Rd	Yes	
329	5/24/21 13:53	Nicole Whitby		580 w Cascade Meadows Loop	Yes	Midway should celebrate its origins as a quaint town with a plan, instead of doing what every other little town does and let commercial building rule Main Street. An arts center would improve nightly entertainment for local hotels and provide great activities for the community, and a dedicated place for performers. Town Hall is no longer adequate for what Midway wants to do with its art scene. I applaud this petition.
330	5/24/21 14:27	Mike Wilton		517 Mission Dr, Midway, UT 84049	Yes	
331	5/24/21 14:54	Bryanna Layer		276 W Canyon View Ln , Midway, UT 84049	Yes	What is the likelihood of getting this to happen? Seems like the commercial development is already a done deal. We will do anything to fight the proposed development
332	5/24/21 15:26	Brad Mickiewicz		910 N 75 W	Yes	
333	5/24/21 15:30	Anna Dance		156 West 300 South	Yes	No more dense housing or commercial development. Keep Midway a hometown look and feel please.
334	5/24/21 16:52	Lorien		294 E Saddle Dr	Yes	
335	5/24/21 16:52	Beverly Snow	bevrsnow@gmail.com	640 S Appenzell Lane, Midway, UT 84049	Yes	Please vote YES to a Midway Arts Center--this is a win-win for our community!!
336	5/24/21 16:53	Karl N Snow	knsnow3@gmail.com	640 S Appenzell Lane, Midway, UT 84049	Yes	I urge you to vote yes to a Midway Arts Center in our community.
337	5/24/21 18:18	Jody Anagnos		35 S 700 E, Midway, UT 84049	Yes	Please let's put thought into future development in Midway. I love the idea of the focal point is open space versus buildings. I also hope we'll be able to keep fireworks on Memorial Hill as they have been.
338	5/24/21 18:19	Brent McElhane		35 S 700 E, Midway, UT 84049	Yes	
339	5/24/21 18:25	Jack Richardson		430 Fairway Dr Midway 84049	Yes	Let's keep Midway special!
340	5/24/21 18:30	Judy Frischknecht		283 S 500 E	Yes	NO MAC in Midway!!!
341	5/24/21 18:49	Kali Smith		900 S Price Farm Court	Yes	The MAC concept looks SO much nicer!! We need an arts center!! So many folks here love and support the arts.
342	5/24/21 18:58	Kara Charlesworth		905 S Price Farm ct	Yes	We need the Arts Center in our town! No shipping centers!!!
343	5/24/21 19:26	Liz Landers		92 Geneva Drive	Yes	
344	5/24/21 19:33	Robert Cobb		539 N Farm Hill Ln	Yes	A wonderful project for Midway.
345	5/24/21 19:34	Adele Landers		92 Geneva Dr, Midway UT 84049	Yes	
346	5/24/21 19:35	Cynthia Cobb		539 N Farm Hill Lane Midway UT 84049	Yes	Great project...
347	5/24/21 20:06	Paul butler		1343 N. Chancey Ln., Midway, 84049	Yes	
348	5/24/21 21:09	Susan Peay		273 west 100 north	Yes	Please let us have the Art Center.

	TIME STAMP	NAME	EMAIL ADDRESS	ADDRESS	MIDWAY VOTER	COMMENTS
349	5/25/21 6:44	Frank Platt		1123 Dutch Fields Pkwy	Yes	We need to re-think development of Midway, both in commercial and residential enterprises. Memorial Hill is unique to Midway. It is our Eiffel Tower and, like the Eiffel Tower, its base should be open space so residents may gather and enjoy its simple beauty. The MAC design allows this to happen.
350	5/25/21 8:27	Erin Seamons		90 N 400 W, Midway, UT 84049	Yes	
351	5/25/21 8:28	Shawn Seamons		90 N 400 W, Midway, UT 84049	Yes	
352	5/25/21 10:09	Nicole Bunker		388 W Sharon Lane, Midway UT 84048	Yes	
353	5/25/21 11:00	David A Dorius		355 N 1400 W Midway, Utah 84049	Yes	** Official Petition Text **Yes, I support the building of the Midway Arts Center.
354	5/25/21 11:01	Allison Dorius		355 N 1400 W Midway, Utah 84049	Yes	** Official Petition Text **Yes, I support the building of the Midway Arts Center.
355	5/25/21 14:46	Ryan Seare		750 N Center st Midway UT	Yes	
356	5/25/21 14:47	Jill Seare		750 North Center St Midway UT 84049	Yes	
357	5/25/21 15:00	Valerie Williams		1116 N. 455 W. Unit #3	Yes	
358	5/25/21 15:01	Roy Williams		1116 N. 455 W. Unit 33	Yes	
359	5/25/21 16:22	John Platt		99 E Main	Yes	I love the MAC plan that preserves open space and Midway's home town feel. It would be so great for new development to match and complement our existing downtown, which this appears to do.
360	5/25/21 20:32	Danya Densley		155 w 200 n midway, ut 84049	Yes	
361	5/25/21 20:46	Brett McGlothlin		1437 Dutch Highland Dr, Midway, UT 84049	Yes	
362	5/26/21 8:35	Eric M Morris		1188 Canyon View Rd., Midway, UT 84049	Yes	
363	5/26/21 14:58	Quinn Calder		146 North 300 East	Yes	NA
364	5/26/21 16:24	Kelly Marshall		105 S 400 E	Yes	
365	5/26/21 18:11	Alexandra Hludzinski		62 Fox Den Rd Midway, UT	Yes	Looks much nicer than retail.
366	5/26/21 18:44			1235 swiss alpine road	Yes	We want the art center. 👍
367	5/26/21 20:52	Kim Craig		1235 Swiss Alpine Rd, Midway, UT 84049	Yes	Yes we want Art Center
368	5/26/21 21:26	Riley Facer		557 craftsman way midway UT 84049	Yes	
369	5/27/21 8:07	Don Greene		340 E 1690 N	Yes	
370	5/27/21 8:08	Michelle Greene		340 E. 1690 N	Yes	
371	5/27/21 8:50	E. Henderson		Maybe	Yes	I still like the whole OPEN view of the land in front of Memorial Hill we don't need anymore buildings put up in this town it attracts way too much attention and traffic becomes too much on Main look at the customers dodging traffic or running across just to get to Lola's they don't use the crosswalk at the lights. Let's just have a wide open space I would rather see the cows there only.
372	5/27/21 10:34			333 East 180 North Midway UT 84049	Yes	Pleas don't allow ugly commercial buildings on Main Street- we need to keep the cham of Midway- less density please.
373	5/27/21 18:53	Marilyn Clark	nwarrenclark@gmail.com	1070 Clearwater Way	Yes	It is so important to keep Midway a charming, quaint place. It can grow ugly or it can grow charming. Commercial buildings proliferate and become visual clutter. Once it's gone, you'll never get it back again! Please, keep Midway close to its European roots!

	TIME STAMP	NAME	EMAIL ADDRESS	ADDRESS	MIDWAY VOTER	COMMENTS
374	5/27/21 20:47	Chris Whitney		745 Dutch Valley Drive Midway UT 84049	Yes	The MAC would add to the resort nature of Midway
375	5/27/21 22:51	Jason Tate		915 Martha Lane Midway, Utah. 84049	Yes	
376	5/27/21 23:04	Tracy Tate		915 Martha Lane	Yes	
377	5/28/21 12:42	Kay Canterbury		625 Sunflower Lane	Yes	
378	5/28/21 16:06	Michael Willits		132 Burgundy Lane , Midway UT 84049	Yes	Fantastic idea. We would love to attend functions at a new Arts Center
379	5/28/21 16:08	Caro Willits		132 Burgundy Lane, Midway UT 84049	Yes	Love the activities presented by the MAC
380	5/28/21 20:34	John Condray		1655 N 300 E Midway UT 84049	Yes	
381	5/29/21 9:06	Meagan Polzella		1103 N Springer View Loop Midway UT 84049	Yes	This looks incredible - I hope we can come together to make the right decision for our beautiful town
382	5/29/21 11:29	Linda Stice		Po 1018	Yes	Please seek appropriate development such as the Midway Arts Center. We have an opportunity at this time to do great things for the future of our town.
383	5/30/21 13:18	Eric Bright		1471 Dutch Canyon Court, Midway UT	Yes	Even if the art center canon become a reality, please leverage the design of the facility to develop the space with Memorial Hill as a backdrop and small shops surrounding a common green area. Look at some of the mixed use developments happening in Farmington Station, 9th & 9th in Sugarhouse, and Desert Color in St. George to leverage the beauty of our surroundings to make a good decision for the future.
384	5/30/21 13:19	Cicely Bright		1471 Dutch Canyon Court, Midway UT	Yes	Please consider alternatives to the age old main street look. We can do better.
385	5/30/21 13:28	David Foster		80 N 200 E, Midway, Utah 84049	Yes	
386	5/30/21 17:31	Rob Foster		625 Sunflower Ln	Yes	
387	5/30/21 19:37	Mark Blasil		1181 Tumbery Woods Dr	Yes	Adding a well thought out and beautifully designed Arts Center will not only bring creativity to Midway, but will help preserve the open feeling of the valley versus other alternatives. Mark and Janet Blasil
388	5/30/21 20:06	Rob Layer		276 west canyon view lane	Yes	
389	5/31/21 11:20	Steve Hofmann		1068 Lime Canyon Rd	Yes	
390	5/31/21 19:23	Patsy Hight		P.O. 94 Midway, Utah 84049	Yes	
391	6/1/21 11:03	Natalie Brooks		621 west boulder point road Midway UT 84049	Yes	So sad you put a cement culvert instead of a beautiful groomed stream right in the center of Midway, please try to get this right.
392	6/2/21 9:02	Andrea Dabier		1347 N Chancey Ln. Midway	Yes	
393	6/2/21 20:07	Jason Hall		693 S Appenzell Ln Midway UT 84049	Yes	
394	6/3/21 8:20	Fred E Thomas		** Official Petition Text **Yes, I support the building of t	Yes	This is an essential business for the betterment of our mountain community.
395	6/3/21 8:22	Leilani D Thomas		Yes, I support the building of the Midway Arts Center. Th	Yes	Love this idea!
396	6/3/21 11:43	Trish Martineau	trishym58@yahoo.com	1347 north Montreux drive midway Utah 84049	Yes	Looking forward to the Midway Arts Center!
397	6/4/21 19:18	Suzanne Phillips		33 North 200 west, Midway Utah	Yes	The Arts Center is so Midway. Let's be amazing!
398	6/5/21 15:14	paul Tayler	paultayler6830@msn.com	267 W Bumts Fields Way Midway, Utah 84049	Yes	
399	6/7/21 7:13	Kayla Hall		693 S Appenzell Ln, Midway, UT 84049	Yes	

	TIME STAMP	NAME	EMAIL ADDRESS	ADDRESS	MIDWAY VOTER	COMMENTS
400	6/7/21 15:25	Rob hyatt		386 E 600 N. Midway, UT 84049	Yes	
401	6/8/21 6:27	Julie davis		228 w fam springs lane	Yes	
402	6/8/21 13:33	Kimberly baker		12 w village circle, midway, ut 84049	Yes	
403	6/9/21 15:10	Aidan		675 Sunflower Ln	Yes	
404	6/10/21 12:23	Laurie Sheehan		1290 Links Dr	Yes	
405		Diane Watts	Russ@wattsenterprises.com	611 Dutch Mountain Dr., Midway, UT 84049	Yes	
406		Dixie Galbraith	jamesanddixie@msn.com	76 E Versailles Way, Midway, UT 84049	Yes	
407		Vicky Bumham	craigburnham46@gmail.com	1205 N. Cottage Way, Midway, UT 84049	Yes	
408	7/5/21 20:04	Elizabeth Wilson	elizabethakerlowwilson@gmail.com	P.O. Box 337	Yes	We are huge supporters of the Midway Arts Center!!
409	7/5/21 20:06	Cameron Wilson	camerondwilson@gmail.com	P.O. Box 337	Yes	We are major supporters of the MAC!
410	7/5/21 20:07	Dick Sanders	Dick.sanders4@gmail.com	74 E Provence Way, midway Utah	Yes	We love this idea that should be supported
411	7/5/21 20:07	Gayle Wilson	wasatchvalleyre@gmail.com	P.O. Box 987	Yes	
412	7/5/21 20:09	Randon W. Wilson	randonwwilson@gmail.com	P.O. Box 987	Yes	
413	7/7/21 8:30	Kate Christensen	kc@kc-a.com	1330 N. Montabon Way, Midway, UT 84049	Yes	
414	7/7/21 8:31	Boyd Christensen	BWChris4@gmail.com	1330 N. Montabon Way, Midway, UT 84049	Yes	
415	7/7/21 23:37	Randy M Mortensen	Randymortensen@gmail.com	1125 Swiss Alpine Road	Yes	
416	7/8/21 18:15	paultavler6830@msn.com	boomoss@icloud.com	681 Dutch Valley Ct, Midway, UT, 84049	Yes	
417	7/9/21 20:00	Presión Willey	prestonwilley@gmail.com	1204 S Stringtown Road	Yes	This is the type of proactive, quality growth that will enrich our community! I'd much prefer an arts center to more commercial development.
418	7/10/21 14:59	Connie Platt	connieplatt@gmail.com	1123 Dutch Fields Parkway	Yes	Limit commercial buildings in Midway
419	7/12/21 19:56	anna greenwell	annagreenwell@yahoo.com	1135 dutch fields parkway midway utah	Yes	
420	7/12/21 21:17	Kimberley Rancie	kimberleyrancie@gmail.com	784 Resort Drive Midway	Yes	A dedicated space for the performing arts, including live music performances, would be a wonderful addition to the community. I have performed at Swiss Days, performed with the HVO and smaller ensembles at the Midway town hall (and TVT) and have children who perform with HVA. I know well the constraints, challenges and extraordinary volunteer hours required to put in all such shows. My regular patronage of town hall events also has also exposed me to the need for larger, more suitable performing space. Midway is growing and we need well rounded facilities to grow along with it. Even if I were not a supporter of the arts I would support the intended location of the MAC. The new "Grainary" is an eye sore and blocks the view of Memorial Hill- an iconic and treasured landmark. Too many houses and commercial buildings are being permitted to build up high, right by the roadside, blocking out the view of all the beauty that people move here for in the first place. Please keep Midway beautiful. Another point: decades of studies have shown that children who grow up having regular involvement in or exposure to fine arts are more literate, more emotionally stable and better contributors to society than their counterparts. Let's make Midway great for the rising generation as well as those here now. Thank you for listening to the community.

	TIME STAMP	NAME	EMAIL ADDRESS	ADDRESS	MIDWAY VOTER	COMMENTS
421	7/12/21 21:28	Caroline Larsen	carolinelarsen@outlook.com	1055 oberland drive midway Utah	Yes	
422	7/16/21 17:21	Rebekah Mickelson	Rmick1011@gmail.com	PO Box 1258 Midway Utah 84049	Yes	
423	7/16/21 19:52	Charis Gray	charisgray12@gmail.com	540 Craftsman Way Midway	Yes	Please build a theater!!
424	7/16/21 20:47	Heather Poelman	heatherpoelman68@gmail.com	840 Bigler Lane Midway Utah 84049	Yes	
425	7/17/21 19:56	William Benz	wrbenz@gmail.com	17Leman Drive, Midway UT 84049	Yes	
426	7/17/21 19:58	Caprice Benz	capricebenz@gmail.com	17 W Leman Drive, Midway, UT 84049	Yes	
427	7/17/21 23:27	Nathan Bames	Nathanamber2014@gmail.com	369 Cottage Creek Ct, Midway UT 84049	Yes	
428	7/23/21 10:39	Jennell Colwell	Jennell.colwell08@gmail.com	30 w 970 s	Yes	
429	7/23/21 11:31	Lon Ballantyne	Oldgeezerton@gmail.com	835 N. Swiss Farn Circle Midway Utah 84049	Yes	The city should be protecting our town not trying to make money via new taxes. In my opinion any government should not be in the business of drastically changing the community under the guise of progress and ever increasing taxes.
430	7/23/21 12:16	Vance whitby	Vance.whitby@gmail.com	580 W Cascade Meadows loop	Yes	
431	7/23/21 13:42	Theresa santoro	Ssantoro81@att.net	1185 N Warm Springs Road	Yes	
432	7/23/21 13:45	Steve Santoro	fishing.tata@gmail.com	1185 N Warm Springs Road	Yes	
433	7/23/21 14:14	Alexandra Hludzinski	alexhlud6@gmail.com	62 Fox Den Rd, Midway	Yes	I feel this idea would be much nicer than just stores along Main St, much prettier look.
434	7/23/21 14:17	William Vincent Hludzins	bkeymaker@aol.com	62 Fox Den Rd, Midway	Yes	More appealing look for the town, like the European Style Village feel and park.
435	7/23/21 14:45	Julie davis	rjdavis@gmail.com	228 e fam springs lane	Yes	Excited to see this happen. It will add value and culture, just like the midway park quote from Brigham young encourages, that we add music and goodness to our lives.
436	7/23/21 15:10	Erin Kelly Padjen	Welkstar@gmail.com	1144 n 455 w unit 8	Yes	Yes I support MAC
437	7/23/21 16:10	Valerie kelson	valkelson@gmail.com	987 w swiss alpine rd, midway, utah84049	Yes	
438	7/23/21 16:32	Tami Morgan	tamimorganlds@aol.com	1485 S 200 W Midway Ut 84049	Yes	
439	7/23/21 16:35	caralee smith	busycarrie@yahoo.com	1347 E. 440 N. Provo, UT 84606	Yes	
440	7/23/21 16:37	Kimberley Canetti	kcanetti11@gmail.com	1377 N Montreux Dr. Midway UT	Yes	So glad this is going to happen....the Arts are an important part of our lives!
441	7/23/21 17:01	Maribel Tita	mttita2@aol.com	1341 W Lime Canyon Road, Midway	Yes	
442	7/23/21 17:31	Bruce Canetti	bruce@bcanetti.com	1377 N Montreux Drive Midway Utah 84049	Yes	Art forever
443	7/23/21 17:44	Jamie Riding	Jamie.riding16@yahoo.com	176 S 80 E Midway Utah 84049	Yes	
444	7/23/21 18:18	Michael Hancock	michaelhancockdc@gmail.com	466 N. Farnhouse Way Midway Utah 84049	Yes	
445	7/23/21 18:47	Katherine Nordberg	Knordberg@yahoo.com	482 n farnhouse way Midway it 84049	Yes	Memorial Hill is a spiritual place to be seen... the arts bring joy....
446	7/23/21 19:46	Brian Andrews	cheesy1962@yahoo.com	1123 N. Warm Springs Rd.	Yes	Looks amazing and would show young performers and artist how much the community values their passion, talent, and commitment to excellence.
447	7/23/21 20:04	Sam Bechthold	sambechthold@gmail.com	1295 Windmill Lane, Midway, UT 84049	Yes	Seems like a great plan.
448	7/23/21 20:05	Julie Bechthold	Juliebechthold@gmail.com	1295 Windmill Lane, Midway, UT 84049	Yes	
449	7/23/21 20:30	Teresa Vincent	teresavin@comcast.net	1227 W Lime Canyon Rd	Yes	
450	7/23/21 20:38	Parker Brown	22parkerbrown@gmail.com	695 E Main St. 2H, Midway, UT 84049	Yes	

	TIME STAMP	NAME	EMAIL ADDRESS	ADDRESS	MIDWAY VOTER	COMMENTS
451	7/23/21 21:51	Jeff Nicholas	jeffreydnicholas@gmail.com	1455 Montchapel Ln, Midway, UT	Yes	What's not to like about having the MAC in the proposed location? It will help support the businesses that already exist on Main St as well as those that will exist in the proposed development. It will add a venue for wholesome family entertainment consistent with the values of the citizens of Midway. It will require no tax dollars but will help generate tax revenue.
452	7/24/21 7:35	Christine Ritchie	Rtchie@aol.com	632 W. Augusta Dr., Midway, UT. 84049	Yes	
453	7/24/21 7:37	Dennis Ritchie	Dennisritchie632@gmail.com	632 W. August Dr., Midway, UT. 84049	Yes	
454	7/24/21 8:21	Laurie Nicholas	laurie.nicholas1@gmail.com	1455 N Montchapel Lane	Yes	
455	7/24/21 8:26	Robert Lochhead	lochheadrb@gmail.com	477 Craftsman Way, Midway UT	Yes	This is a no-brainer. The arts center makes perfect sense.
456	7/24/21 8:28	Yes	Susanpeay@gmail.com	273 west 100 north Midway UT	Yes	
457	7/24/21 9:12	Holly Carlson	holly@realestateinparkcity.com	362 Alpinhof Circle	Yes	We would love to see Midway unique from other towns.
458	7/24/21 11:14	Evan Miller	evanmiller92@hotmail.com	1094 N Springer View Loop	Yes	
459	7/24/21 11:15	Latecia Miller	latecia@live.com	1094 N Springer View Loop	Yes	
460	7/24/21 12:11	Thomas Landry	Tomlutah@gmail.com	PO Box 1176	Yes	Yes, I support Art Center.
461	7/24/21 12:44	Gabriele Landry	skihike@outlook.com	PO Box 1176 Midway UT 84049	Yes	Great idea!
462	7/24/21 13:16	Kim Guthrie	gkguthrie@hotmail.com	995 Lacy Lane	Yes	
463	7/24/21 13:16	Glenn Guthrie	gkguthrie@hotmail.com	995 Lacy Lane	Yes	
464	7/24/21 15:10	Susan Magoffin	susanmagoffin47@gmail.com	PO Box 747 midway Utah 84049	Yes	
465	7/24/21 16:21	Susana Williamson	Suzdav78@gmail.com	136 W 300 S, Midway, UT 84049	Yes	Keep Midway beautiful, with the addition of the Midway Arts center and a European style village. NOT more commercial!
466	7/24/21 17:07	Lauren del francia	Lauren.delfrancia@gmail.com	64 south 550 east midway utah	Yes	Please preserve the view of memorial hill!
467	7/24/21 17:37	Yee	lafayhanson@yahoo.com	1236 Homestead Dr.	Yes	A beautiful edition to our city. Amazing programs
468	7/24/21 21:30	Sue Mantyla	suemantyla@gmail.com	626 Dutch Valley Court, Midway UT. 84049	Yes	I'm soo excited for this project! Midway is a destination! People love to come and enjoy great local food, cultural events and rural living! I feel this project will bring more beauty to our Main street! We can hardly wait!
469	7/24/21 22:05	Amy Huber	Amy.huber1987@gmail.com	166 N 400 W	Yes	
470	7/25/21 9:30	Dan Hatch	mdhatch@gmail.com	1049 N. Meadowcreek Ct, Midway, UT 84049	Yes	
471	7/25/21 15:12	Janice Nelson	Janice.Nelson@imail.org	73 Versailles Way	Yes	We need this in Midway.
472	7/25/21 17:10	Eric battles	Ebattles@gmail.com	1202 Dutch Fields Pkwy	Yes	We would love to have this new MAC in our community. What a great way to encourage the arts in our community.
473	7/25/21 17:10	Mark Stiegemeier	mstieg@hotmail.com	522 N Granary Ln , Midway	Yes	Wonderful plan!
474	7/25/21 17:11	Marcy Stiegemeier	marcystieg@hotmail.com	522 N Granary Ln, Midway	Yes	Outstanding!
475	7/25/21 17:56	Camille Fostet	Camillecurtisfostet@gmail.com	1312 Dutch Fields Pkwy	Yes	A great addition to the community
476	7/25/21 18:23	Yes	Beckyfortie@hotmail.com	184 S. 550 E.	Yes	
477	7/25/21 19:26	Erin Harris	erinharris@gmail.com	915 Dutch View Ct	Yes	
478	7/26/21 10:45	Chris & Joni Bonnell	chris.bonnell@wgu.edu	1135 N 520 W, Midway, Utah 84049	Yes	
479	7/26/21 10:58	Philip Perkins	zskiracer@gmail.com	885 s whitewater way midway Utah 84049	Yes	
480	7/26/21 11:40	DENNIS BRUNE	denmarb@aol.com	1152 No. Village Circle	Yes	
481	7/26/21 11:57	Linda Olsen	Olsens95@comcast.net	PO Box 927	Yes	

	TIME STAMP	NAME	EMAIL ADDRESS	ADDRESS	MIDWAY VOTER	COMMENTS
482	7/26/21 12:46	Amber Barnes	inhispeace@gmail.com	369 Cottage Creek Ct	Yes	I would love to see this land being used for an arts center and open space, which will beautiful and enhance the over all community by bringing in wonderful productions, and a place to walk around and relax—and maintain the charm of this quaint town! I'd much rather have this go in than a crammed apartment/condo development! Thanks!
483	7/26/21 13:51	JANET L MORTENSEN	Randymortensen@gmail.com	1125 Swiss Alpine Road, Midway, UT 84048	Yes	
484	7/26/21 15:23	Isaac Button	lrbutton@gmail.com	193 w canyon view lane	Yes	
485	7/26/21 18:32	Steven Avey	Aveyrph@gmail.com	1030 Oberland Dr, Unit 5, Midway, UT 84049	Yes	The MAC and Village will be a huge benefit to our community
486	7/26/21 18:36	L Colleen Avey	cmumav1@gmail.com	1030 Oberland Dr. Unit #5	Yes	I think the Midway Arts Center would be a wonderful addition to this beautiful city and benefit businesses and individuals.
487	7/27/21 13:52	Frank Douglas Dent	fddent@gmail.com	101 W 100 S, Midway UT 84049	Yes	
488	7/27/21 15:16	Deborah Stimson Snow	snowbizness@hotmail.com	P.O.box 997 Midway UT	Yes	I founded a Performing Arts Center in PA in 2007 which is still going strong. It became a magnet for businesses, culture and community unlike anything that the town had ever seen. It also provided a safe and healthy atmosphere for kids education in the arts. There are not downsides to this addition to our neighborhood.
489	7/27/21 16:57	Nan Hutchins	Nanhutchins@msn.com	91 W Village Ct	Yes	Very best thing for Midway!!!
490	7/27/21 18:13	Robert B Hutchins	brucehutchins@msn.com	91 w Village Court	Yes	The MAC is absolutely necessary to maintain the uniqueness of Midway that we all love.
491	7/27/21 20:09	Brie Eddington	brie.e@aggiemail.usu.edu	921 Price Fam Ct. Midway, Utah 84049	Yes	
492	7/27/21 21:32	Leonard Wilkerson	Leonardbwilkerson@gmail.com	461 W 970 S, Midway UT 84049	Yes	
493	7/27/21 22:13	Jane Ballantyne	Ballantyne.j.an@gmail.com	835 N Swiss Fam Circle, Midway	Yes	
494	7/28/21 7:15	Colin Taylor	ccolintaylor@gmail.com	862 E Hamlet Cir S. Midway, 84049	Yes	Thank you!
495	7/28/21 8:36	Britt Manning	manning.britt@gmail.com	552 S. 250 W. Midway, UT 84049	Yes	We support keeping Midway charming with an arts center rather than a commercial development.
496	7/28/21 8:52	Candy Morken	candystan@gmail.com	1430 Dutch Fields Pkwy, Midway	Yes	
497	7/28/21 9:28	Dave Brewer	thtdave17@gmail.com	380 e 600 n	Yes	
498	7/28/21 9:32	Clarence and Lois Mahon	clmidway@gmail.com	PO Box 83, Midway , UT 84049	Yes	We hope you can accept both our names as we only have one cell between us.
499	7/28/21 11:01	James F Brown	james@avalaunchmedia.com	1124 Dutch Fields Pkwy, Midway, Ut, 84049	Yes	Our whole family is in favor of this amazing project. Please approve it!
500	7/28/21 14:47	Anna Dance	AnnaD@mwciutah.com	156 West Michie Lane	Yes	We don't need Midway to look like Orem- we need to preserve what makes this place special
501	7/28/21 15:41	Margo France	mgsfrance1@gmail.com	1084 N Matterhom Court	Yes	A real plus for Midway. We don't need any strip malls. Lets maintain our unique setting and heritage!!!
502	7/28/21 19:30	Renea Nilsson	Renea.nilsson@gmail.com	491 Mission Dr. Midway, UT 84049	Yes	
503	7/29/21 13:46	Belinda Andrews	Bebruneman@yahoo.com	1123 N. Warm Springs Rd Midway 84049	Yes	I vote yes on midway Arts Center!
504	7/29/21 19:07	Tyler Dow	td@tylerdow.com	900 Michie Lane	Yes	Thanks Folks
505	7/29/21 19:33	Jann Jensen	jakjensen@yahoo.com	902 Michie Lane	Yes	I signed this as the lesser of two evils. I hate the commercial buildings that it's zoned for, but I'm also afraid that the Arts Center may not be self sustaining in the long term.

	TIME STAMP	NAME	EMAIL ADDRESS	ADDRESS	MIDWAY VOTER	COMMENTS
506	7/29/21 19:47	Dans Dow	danaldow@gmail.com	900 michie lane	Yes	
507	7/29/21 20:46	Carolee Kohler	Kohlercarolee@gmail.com	61 Burgundy Lane, Midway, Utah	Yes	
508	7/29/21 20:48	William Kohler	kohlercarolee@gmail.com	61 Burgundy Lane, Midway, Utah 84049	Yes	
509	7/31/21 9:10	Jennifer Chipman	Jenniferjchipman@gmail.com	1630 N 450 E Midway Utah 84049	Yes	
510	7/31/21 9:19	Matthew Chipman	Mchipman71@gmail.com	1630 N 450 E, Midway, UT 84049	Yes	
511	8/1/21 12:42	Richard Noel	rnoel@mac.com	183 W Canyon View In	Yes	Thanks!
512	8/2/21 15:54	FAKLER,KENNETH J	kmfakler@msn.com	P.O. Box 1357, Midway, Utah 84049	Yes	
513	8/2/21 15:55	Karen M Fakler	kmfakler@msn.com	P.O. Box 1357, Midway, Utah 84049	Yes	
514	8/3/21 9:09	Alicia Vineyard	avine99@gmail.com	97 Geneva Dr. Midway, UT	Yes	
515	8/3/21 11:38	James Ballstaedt	james@nbw32.com	1670 Dutch Canyon Rd	Yes	
516	8/3/21 14:54	Shana Edmunds	s.edmunds@live.com	1097 N Matterhom Ct. Midway, Ut. 84049	Yes	
517	8/3/21 19:08	Kristen Ballstaedt	kristen@nbw32.com	1670 Dutch Canyon Road	Yes	
518	8/3/21 22:26	Pam Weilenmann	Playapamela@hotmail.com	8 E Village Cir.	Yes	Let's not stumble forward into our lovely town's future , allowing short term developers for self profit make their quick money and walk away . The goal of the largest profit for the least construction cost was not what our struggling forefathers chose for the Town Hall, Glockinspheil,
519	8/4/21 20:41	Penny Frates	Mayfrates@hotmail.com	804 E Hamlet Cir N	Yes	
520	8/6/21 15:53	Harry Weyandt	harryweyandt@hotmail.com	190 E Main S	Yes	Let's get the MAC approved! We are all in my family!
521	8/6/21 15:57	Vickie Weyandt	Momweyandt@hotmail.com	190 E Main St	Yes	You have our support. Would be a great asset to our community. Mayor & City Council, please vote to approve!
522	8/8/21 13:12	Thomas DeJong	tommygofast@gmail.com	234 Edelweiss Lane	Yes	
523	8/8/21 13:13	Danielle DeJong	englehomd@gmail.com	234 Edelweiss Lane, Midway 84049	Yes	
524	8/8/21 19:19	Ron Parker	rparker@aol.com	PO Box 1266 Midway, UT	Yes	I'd like to see it happen.
525	8/11/21 11:15	Hollie Kent	hkent22@hotmail.com	1420 S 200 West Midway Ut 84049	Yes	Midway needs responsible planning for the future that will preserve and continue the arts that all the residents of Midway can enjoy, young and old.
526	8/20/21 15:51	Cheryl Fox	cheryl_fx@yahoo.com	1269 canyon view road. midway, utah. 84049	Yes	
527	8/28/21 13:08	Henry Wreden	hdrbzen@yahoo.com	783 double eagle drive	Yes	
528	9/3/21 16:37	Kay Canterbury	kaybury@gmail.com	625 Sunflower Lane	Yes	
529	9/8/21 18:15	Terri L Aime	terriaime@gmail.com	168 West Monte Rosa Ln	Yes	
530	9/19/21 10:54	Meshelle Kijanen	mkijanen1@gmail.com	939 Schneitter Circle Apt 1	Yes	
531	10/17/21 15:45	Lee McCullough	leesmcculloughiii@gmail.com	PO Box 758, Midway, Utah 84049	Yes	
532	10/17/21 15:51	Cheryl A. McCullough	cheryl.mccullough@me.com	PO BOX 758 MIDWAY UT 84049	Yes	
533	11/4/21 20:22	Kara Hunter	karahunter09@gmail.com	521 S 250 W, Midway, UT 84049	Yes	We just moved here and I took my 3 girls to see little mermaid! Such talent among these young kids. I hope we all do what we can to preserve this small town and keep the quaintness that is what we all love. Don't ruin our view of memorial hill with more shops...if you want to add something, bring art and culture to this amazing town.
534		Ilene giles	llenemgiles@gmail.com	790 Dutch Farms Ct., Midway, UT 84049	Yes	
535			carolyncrobison@yahoo.com		YES	
536			dreyscott@gmail.com		Yes	

	TIME STAMP	NAME	EMAIL ADDRESS	ADDRESS	MIDWAY VOTER	COMMENTS
537			mindymcmaster@icloud.com		yes	

Petitions in favor of bringing The MAC to Midway - non-Midway residents

2	3/27/2021 21:37:43	Brynn Harris	brynn.harris@hotmail.com	1155 E 2100 S Salt Lake City	No	
3	3/27/2021 21:40:14	Abbie McGinty	Bellabeaphoto@yahoo.com	1011 W. Countryside Circle heber	No	I vote for plan B with the open space & arts center
4	3/27/2021 21:42:49	Cynthia Neider	ctneider@gmail.com	928 Ledgestone Lane	No	Please support this Midway Arts Center that will bless the entire community with the joy of live performances! Support for the arts adds refinement, inspiration and beauty to any community. We need a quality center to house the talent and creative expression of our youth and performers of all ages.
5	3/27/2021 22:08:14	Elisabeth Crellin	acey_c@hotmail.com	339 Fredrick Ct.	No	
6	3/27/2021 22:08:14	Elyse Stoedter	elya_tay@hotmail.com	120 south 200 east Heber	No	I wholeheartedly support the construction of the Midway Arts Center in front of Memorial Hill. This seems like a no-brainer.
7	3/28/2021 22:25:31	kate robison	katearobison@gmail.com	577 N granary way	No	i love high valley arts. i would love to see the MAC center come to midway. i've come every years for 4 years and it's about time we get a theater!
8	3/28/2021 22:25:31	Rob Bolick	rob@rbolick.com	PO Box 967, Midway	No	
9	3/29/2021 8:19:46	Aaron Johnson	aaronwade6263@gmail.com	662 school house way, heber city, UT 84032	No	
10	3/29/2021 8:24:36	Braelyn Smith	braelynsn@icloud.com	900 s Price Farm Court	No	
11	3/29/2021 8:42:11	Marvin Rust	mtrust21@msn.com	1008 Cobblestone Dr, Heber City, UT 84032	No	A theater in Midway will help make Midway the jewel of the Valley.
12	3/29/2021 8:57:51	Jessica King	jessicaking227@gmail.com	1976 Graystone Ln	No	Community theater brings a community together!
13	3/29/2021 9:00:40	Emily Nelson	emilymelson@gmail.com	1576 E 560 S	No	I support
14	3/29/2021 9:58:54	Jessica Ellingford	Jessellingford@gmail.com	1061 E 2880 S	No	
15	3/29/2021 10:25:27	Glenda Greenfield	Erincorbridge1@gmail.com	402 W 1120 S, Midway, UT 84049	No	Yes, I support the building of the Midway Arts Center theater. The MAC will preserve Memorial Hill and green space in downtown Midway and should be approved by the City Council as soon as possible.
16	3/29/2021 10:40:22	Anna Cox	mountainhigh@gmail.com	1430 East Preakness Lane	No	The Art's are so important to support in any community!! They are the life line for humanity!
17	3/29/2021 11:40:16	Jennifer Bosshardt	jennb_8@yahoo.com	735 W 1250 S, Heber City, Utah 84032	No	
18	3/29/2021 11:51:34	Darryl Bosshardt	darrylb@realsalt.com	735 W 1250 S Heber City, UT 84032	No	
19	3/29/2021 13:43:01	King	Krystalclingo@gmail.com	1315 W Box Elder Lane, Price, UT 84501	No	We don't live here, but love midway and think Plan B would keep Midway beautiful.
20	3/29/2021 13:43:01	Steven Dahl MD	sidahimd@yahoo.com	1392 north Chancey LN. MIDWAY UT	No	The musicals are part of the uniqueness of Midway. Keep them coming
21	3/29/2021 16:11:02	Adele Sampson	adeleandabcd@ymail.com	2924 E 1400 S Heber City, UT 84032	No	
22	3/29/2021 16:42:05	Jessica Potter	jessicapotter36@gmail.com	1175 Cottonwood Circle	No	
23	3/29/2021 16:42:05	Paula Dahl	Ppdahl@yahoo.com	1392 N. Chancey Ln. Midway, UT 84049	No	
24	3/29/2021 19:33:59	Jill Faatz	jillfaatz@hotmail.com	935 Ledgestone, Heber City, UT 84032	No	
25	3/29/2021 21:20:41	Holly Alden	redpondhouse@gmail.com	2190 west 1200 south Heber	No	I support midway arts center

	TIME STAMP	NAME	EMAIL ADDRESS	ADDRESS	MIDWAY VOTER	COMMENTS
26	3/29/2021 21:20:41	Julie Tidwell	Julietidwell@gmail.com	3528 Stonewall Circle	No	
27	3/29/2021 22:55:54	Brendon French	brendon.n.french@gmail.com	562 N 200 E #13 Provo, UT 84606	No	
28	3/30/2021 9:41:45	Creighton Baird	creighton184@gmail.com	360 Anna lane	No	
29	3/30/2021 13:34:39	Cami Hoff	cachoff@hotmail.com	1401 Meyerwood Ln. Highlands Ranch, CO 80129	No	
30	3/31/2021 8:54:19	Ted Greenfield	Erincorbridge1@gmail.com	402 W 1120 S, Midway, UT 84049	No	Yes, I support the building of the Midway Arts Center theater. The MAC will preserve Memorial Hill and green space in downtown Midway and should be approved by the City Council as soon as possible.
31	3/31/2021 22:34:05	Jason Rees	jasonrees29@yahoo.com	856 S 4225 W	No	I look forward and support the Midway arts center.
32	3/31/2021 22:34:05	Peter R. Rancie	peter.rancie@gmail.com	784 Resort Drive	No	While I'm not a registered voter, I am a principal in the resort precinct of Midway, with roles that are integral to the commercial development and tax base of Midway City. My considered view is that this project is not only complementary - it is strategically important- to Midway City and the hospitality future of Midway in particular and Heber Valley at large.
33	4/1/2021 5:58:44	Deborah VanLeeuwen	deb.vanleeuwen@gmail.com	876 S LedgeStone, Heber City UT 84032	No	
34	4/1/2021 10:46:06	Joel Baer	baercat@gmail.com	920 s Coldwater way midway UT 84049	No	
35	4/1/2021 11:14:21	Jorge F Peña	jfpena58@gmail.com	360 Anna In Midway	No	Bring the MaC to midway
36	4/1/2021 11:14:21	Quinn Bennion	qbennion@yahoo.com	212 Flour Mill Road, Heber City, UT, 84032	No	The Heber Valley is in need of a performing arts center and what a better place than Midway to give visitors a location to get some great entertainment. High Valley Arts has given my family way to build character, confidence, and be involved with wonderful people from the community. The center would be a great benefit to Midway and the entire valley.
37	4/1/2021 12:09:59	Lisa ilizaliturri	lmutilaziliasil@yahoo.com	198 Keetley close dr kamas ut 84036	No	
38	4/1/2021 12:09:59	Natalie Edwards	nataliecedwards@yahoo.com	873 LedgeStone Ln	No	We would love a theater for Heber Valley!!! It is a much needed addition to our great place!!
39	4/1/2021 16:52:12	Kelli Bills	Kellibills@gmail.com	435 S 300 E, Midway, UT 84049	No	
40	4/1/2021 16:52:12	Scott Edwards	Scott.d.edwards@gmail.com	873 LedgeStone Ln.	No	Live in Heber
41	4/1/2021 21:48:15	Valerie Springer	valspring4@gmail.com	446 E 2010 S	No	A community that invests in the ARTS will always win. Everyone can have more strip malls, the towns that stand out are the ones that recognize the importance of preserving the performing arts. Please vote plan B.
42	4/1/2021 23:00:02	Shauna Goates	sgoates@gmail.com	377 East Huckleberry Lane, Heber City, UT 84032	No	
43	4/1/2021 23:02:56	Richard Goates	Rich.goates	377 East Huckleberry Lane, Heber City, UT 84032	No	
44	4/2/2021 5:30:57	Janene Zimmerman	queennener@sbcglobal.net	1126 Fieldstone Ct, Heber City, Ut 84032	No	
45	4/2/2021 5:38:30	Susan Fassold	Sfassold@yahoo.com	351 E 100 S Heber UT 84032	No	
46	4/2/2021 5:57:22	Karen Christensen	Brownielovers@gmail.com	6632 Fairfax Drive, Provo, UT 84604	No	I live in nearby Provo Canyon and love to enjoy the productions in Midway. Please keep them alive.
47	4/2/2021 6:05:12	Pat Bramlage	bpbramlage@gmail.com	P.O. Box 910117 St George, Ut 84791	No	

	TIME STAMP	NAME	EMAIL ADDRESS	ADDRESS	MIDWAY VOTER	COMMENTS
48	4/2/2021 6:19:26	Sally Lutz	Sally.lutz@gmail.com	434 Fairway , Midway,TX 84049	No	One of the reasons we love Midway, is the small town feel and open space. Community theatre and open space combine to make this option so attractive!
49	4/2/2021 6:46:58	Tracy Mullen	Rotracy@yahoo.com	Po box 186 Kamas Utah 84036	No	
50	4/2/2021 6:51:04	Linda C. Christensen	Lindac@lindacurley.com	PO Box 126 Wallsburg Ut 84082	No	Having been involved in the arts and community organizations for years, as well as working with SLC to establish an arts center in the 1980's i can say without a doubt that this opportunity should not be passed up. Planning ahead to create a beautiful center point like the proposed MAC near memorial hill is genius. Now is the time to act!
51	4/2/2021 6:51:46	Deb Mishurda	mishurdamtranches@gmail.com	7931 West Hills Trail. Park City, UT. 84098	No	My husband and I have lived in the area for a short 10 years and have throughly enjoyed the performing arts in Midway. Keep it alive!
52	4/2/2021 6:55:35	Vicky McCombs	frogsandangels@gmail.com	230 S 800 E Hyrum Ut 84319	No	We enjoy the shows and there is a need for a building that they can perform in
53	4/2/2021 7:00:31	George M. Hyde	gmhyde@gmail.com	80 Burgundy Ln, Midway, UT	No	We have owned our home in Midway for 10 years, and have always planned our time in Midway to be sure to attend the High Valley Arts summer production. Growth in our beautiful valley is inevitable. So when an opportunity arises to steer that growth in a way that preserves some of the small town charm, we should take advantage of it.
54	4/2/2021 7:00:49	Miriam Strassberg	Miriamb@me.com	7962 Oakledge Road	No	
55	4/2/2021 7:02:51	Julia Jones	wtw.julia@gmail.com	444 Fairway Drive, Midway	No	Moving from Summit Park to Midway
56	4/2/2021 7:07:00	Avi Velarde	avijoy777@gmail.com	4995 N Luralwood St	No	
57	4/2/2021 7:07:04	Nelda Mcallister	Nelda.mcallister@gmail.com	1470 Lost Colt Dr. Heber, UT 84032	No	
58	4/2/2021 7:07:51	John E. Murphy	jemurphy51@me.com	542 Inveness Ln, Heber City, UT 84032	No	Registered voter in Heber
59	4/2/2021 7:14:12	Jane M. Kinsel	janemkinsel@yahoo.com	1025 Cobblestone Drive. Heber, utah	No	I Don't live in Midway but consider as a community that could benefit from the arts center.
60	4/2/2021 7:22:31	Gail Keene	keene.gail@gmail.com	1116 W Lime Canyon Rd, Midway, Utah	No	Love the family friendly shows. And love the green space.
61	4/2/2021 7:25:01	Alison Pelletier	alison_pelletier@yahoo.com	9015 northcove dr, Park City, ut 84098	No	
62	4/2/2021 7:25:40	Coy Keene	Coy.keene@gmail.com	2928 Fondren, Dallas, Tx 75205	No	Love midway and the shows. We have a house there and want to see the Arts grow. Midway address is 1116 W Lime Canyon Rd
63	4/2/2021 8:15:21	Heidi I. Jaeger	heidiirene1@gmail.com	7980 Long Rifle Rd. Park City	No	I have regularly attended these productions out in the field of Midway. A Performing Arts Center would be a huge draw for those who cannot set up and sit outdoors to see these amazing performances.
64	4/2/2021 8:18:26	Shannon Zimmeman	shannybabe@sbcglobal.net	4251 W Juniper Shade Drive Herriman UT 84096	No	
65	4/2/2021 8:20:20	Dennis Gailey	Dennis.gailey@yahoo.com	636 West 1250 South Heber	No	I feel this would be a great addition to Midway and the valley.

	TIME STAMP	NAME	EMAIL ADDRESS	ADDRESS	MIDWAY VOTER	COMMENTS
66	4/2/2021 8:21:22	David B Rimington	Rim6db7@gmail.com	1085 Cobblestone Drive, Heber City	No	Among all your other considerations, remember the value the arts are to developing well rounded communities. In our present splintered and hurting nation and cities, we need to balance our lives.
67	4/2/2021 8:30:34	Kay Rust	Kedrust@msn.com	1008 Cobblestone Heber Utah	No	We have been active in High Valley Arts since its beginning. I have seen the wonderful experiences that the Midway children and adults have had who participated and the long and arduous hours of those who set up and tear down sets and staging. It's time that they have a theater so that the program can grow.
68	4/2/2021 8:33:26	Dennis Brune	denmarb@aol.com	1152N Village Circle Midway, UT 84049	No	
69	4/2/2021 8:39:03	Harold L. Rust	hlrust88@gmail.com	18280 Delenka Lane, Lake Oswego, OR 97034	No	I have seen several of your performances while visiting in Heber. It is very possible we may move to Heber in a short time and the prospects of having this fine performance center close by is something I strongly support. Such an event center enhances the quality of life and makes everyone's experience in the Heber Valley— whether a resident or a visitor—much more gratifying and meaningful.
70	4/2/2021 8:41:12	Barbara Lee	ibbarb@hotmail.com	2910 Comistas Drive, Walnut Creek, CA	No	
71	4/2/2021 9:00:54	Leslie Mower	KL_mower@yahoo.com	2942 S 3600 W, Heber UT. 84032	No	I live in Charleston
72	4/2/2021 9:27:10	Linda McCausland	lpmccausland@yahoo.com	21 Eagle Point Court, Park City, Utah	No	
73	4/2/2021 9:29:24	Abby Sheffield	abbyesheffield@gmail.com	441 E 3540 N Provo, UT 84604	No	We love midway for theater performances!
74	4/2/2021 9:34:52	David Waldrip	goodmojo@frontier.com	11132 NW Montreux Ln, Portland, OR 97229	No	
75	4/2/2021 9:38:31	Melody Hughes	melody.brucehughescpa@gmail.com	377 S Mesa Hills Dr Cedar City, UT 84720	No	We love coming to Midway at least once a year for these performances, and we always bring friends with us.
76	4/2/2021 9:39:47	Bruce Hughes	bruce@brucehughescpa.com	630 W 200 N Cedar City, UT 84720	No	We make several trips a year to watch these performances.
77	4/2/2021 9:40:07	Nancy Johnson	nsjslc@juno.com	1905 E. 260 S. Heber, Utah	No	Registered voter in Heber. I am very much in support of the new theater and green space. Let us keep Midway the charming town it is.
78	4/2/2021 9:53:57	Terri Caldwell	terrcaldwell@msn.com	1595 E. Center Creek Rd., Heber City, Utah	No	
79	4/2/2021 9:54:41	Rudy M Caldwell	terrcaldwell@msn.com	1595 E. Center Creek Rd., Heber City, Utah	No	
80	4/2/2021 9:55:32	Donna McNabb	McNabb@netutah.com	755 West Carousel Circle., Cedar City, UT	No	Yes we support the arts
81	4/2/2021 9:55:32	Frank McNabb	McNabb@netutah.com	755 West Carousel Circle, Cedar City, Utah	No	Yes, we support the arts
82	4/2/2021 10:02:27	Robert Johanson	rob@rvjcpa.com	2700 Baywater Place, Thousand Oaks, CA 91362	No	We are second home residents in Midway and support the building of the Midway Arts Center Theatre.
83	4/2/2021 10:08:56	Peter Bray	psbray6@gmail.com	1983 Fieldstone Lane, Heber UT	No	
84	4/2/2021 10:09:53	Jacob McCrory	jacobmccrory@hotmail.com	7888 S. Peak Dr. West Jordan, UT, 84088	No	
85	4/2/2021 10:17:49	Keith Rust	keith@rustfamily.com	4862 W Wexford Way, South Jordan, UT 84009	No	
86	4/2/2021 10:19:42	Aaron Waldrip	mickwaldrip@hotmail.com	2813 Brinker Ave Ogden UT 84403	No	

	TIME STAMP	NAME	EMAIL ADDRESS	ADDRESS	MIDWAY VOTER	COMMENTS
87	4/2/2021 10:42:25	Allison Buhlman	allispiano@Hotmail.com	2044 S 400 E Heber City, UT 84032	No	Even though I do not live in Midway city limits (I live in Heber City), this Midway Art Center will bless many in the surrounding community and beyond. This growing community needs a venue to house the many performances and events in the art community. Fine arts are a vital part of education, and the MAC will help to ensure adequate facilities to continue expanding this field in our community.
88	4/2/2021 10:50:09	Roger Thompson	roger@tmequities.com	428 E. Winchester, #100, Salt Lake City, UT 84107	No	I think an Arts Center in Midway would benefit Midway and the Heber area in so many great ways. Not only could the performing arts flourish, but there would also be a positive economic benefit to the local economy. It looks like there is already a hub of enthusiastic and experienced actors, directors and producers in Midway who would certainly help make this project successful.
89	4/2/2021 10:51:24	Elizabeth Gallagher	elliecat1@msn.com	128 Timberlakes Heber City, UT 84032	No	Yes, I support the building of the Midway Arts Center theater. The MAC will preserve Memorial Hill and green space in downtown Midway and should be approved by the City Council as soon as possible.
90	4/2/2021 11:00:56	Janet Greenhalgh	jgreenouxh@msn.com	1652 N 270 W Pleasant Grove Ut 84062	No	This would be a great addition to the area. Even though I don't live here, I have had the privilege of performing for two shows and I love the arts, so I am very much in favor of this.
91	4/2/2021 11:32:30	Joan Olson	jonibalogne@gmail.com	581 s 980 e Heber City, UT	No	We need a better performing and recital venue in Heber Valley.
92	4/2/2021 12:03:22	Bob Griffin	regrif@outlook.com	P.O.Box 3397. Evansville,IN 47732	No	High Valley does a great job and draws many visitors to Midway
93	4/2/2021 12:31:37	Sharon Mardula	mtnshaaping@gmail.com	5790 mountain ranch dr park city it 84098	No	
94	4/2/2021 12:46:05	Elizabeth Wood	liz.wood@octanner.com	6282 Granada Drive	No	I drive up from Salt Lake and try not to miss any performances because they are GREAT !!! I will continue to support this great center and all it does to help children and entertain the masses !!!
95	4/2/2021 12:51:37	Emily Johnson	edwaldrip@hotmail.com	831 south Rice road	No	
96	4/2/2021 14:52:43	Janalee Hendry	janaleedespain@hotmail.com	576 E 400 S, Heber city	No	
97	4/2/2021 15:34:46	John Richards	J2granite@aol.com	1390 Embassy Way. Salt Lake City, Utah. 84108	No	You have done a fabulous job with all the past performances. Keep up the good work. The new digs sound great.
98	4/2/2021 17:44:32	Daniel Johnson	engineeringenius@gmail.com	831 S Rice Rd, Farmington UT 84025	No	Yes, I support the building of the Midway Arts Center theater. The MAC will preserve Memorial Hill and green space in downtown Midway and should be approved by the City Council as soon as possible.
99	4/2/2021 19:07:04	Raylene	raylenecottle@gmail.com	4051 East Center Creek Rd., Heber City, UT 84032	No	
100	4/2/2021 19:21:17	Shaman Holloway	Shaman.holloway@gmail.com	12831 wild mare way	No	
101	4/2/2021 19:22:06	Scott Holloway	Scottholloway123@gmail.com	12821 wild mare way	No	

	TIME STAMP	NAME	EMAIL ADDRESS	ADDRESS	MIDWAY VOTER	COMMENTS
102	4/2/2021 20:08:52	Helen Cummings	emailhelenc@gmail.com	8836 S Greenwich Ln, Sandy, UT 84093	No	The MAC design is beautiful and compliments the uniqueness of Midway.
103	4/2/2021 22:31:16	Tina Moore	tinagentrymoore@icloud.com	457 W Argyll Ct Heber City, Utah 84032	No	
104	4/2/2021 22:51:05	Jeremy T. Marsh	sithdragon@yahoo.com	585 east 400 south heber Ut 84032	No	
105	4/3/2021 7:46:43	R. Ted Stagg	teds@khsa.biz	1587 East Spyglass Hill Drive, Draper, Utah 84020	No	We attend and support Midway Arts Center theater.
106	4/3/2021 9:22:31	Kayleanna Zaccardi	Kaylee343@yahoo.com	1516 east 1050 north	No	Yes, I support
107	4/3/2021 9:36:10	Wendy Reioux	beantrees84@gmail.com	Beantrees84@gmail.com	No	I am not a registered voter in Midway but I am in Heber where I live and over the last few years that we have been in this valley we have very much enjoyed the shows you put on! Your group is very talented and deserves and beautiful space to perform. (Although I would miss the out door performances in the summer! There is something really fun about theater outside in the summer!)
108	4/3/2021 10:02:51	Kristi Carter	kristisbouquet@yahoo.com	889 Comerstone Lane, Heber, Utah	No	This facility will be greatly appreciated and is much needed.
109	4/3/2021 15:14:15	Jenny Waldrip	Jjwaldrip@icloud.com	Eden UT	No	The Mac would be a wonderful addition to Midway! Please support this project.
110	4/4/2021 7:37:10	Tracy Thome	tnelson153@hotmail.com	440 E Huckleberry lane Heber Utah 84032	No	
111	4/4/2021 7:40:09	Zac Johnson	7leepz@gmail.com	1615 East 1050 North	No	The theater brings families and friends together. Strengthening our community and our State
112	4/4/2021 7:56:00	Trena Zaccardi	tzaccardi00@gmail.com	1615 East 1050 north Heber utah	No	We are surrounded by beauty in this valley and so much of it is disappearing, please help to reserve the beauty that and arts here in and around our community
113	4/4/2021 8:20:59	Duane L. Jones	lhomond@comcast.net	500 W 200 N Midway, UT 84049	No	
114	4/4/2021 21:37:28	Carly Reese	carlyreese@gmail.com	1956 Cobblestone Dr, Heber City, UT, 84032	No	
115	4/5/2021 8:39:09	Morgan Murdock	morganmurdock@gmail.com	845 E 170 N Heber, UT 84032	No	I'm a registered voter in Heber.
116	4/5/2021 19:37:00	Estefanya Jenson	yuri@bilingualfamilyservices.com	274 Timberlakes EST Heber City	No	Yes, I support the building of the Midway Arts Center theater. The MAC will preserve Memorial Hill and green space in downtown Midway and should be approved by the City Council as soon as possible.
117	4/5/2021 20:49:14	Katie Stirling	emailkatiestirling@gmail.com	367 Waterside Rd, Heber UT 84032	No	I am a resident of Heber, but have enjoyed HVA's productions, including many that my kids have participated in as a cast member.
118	4/6/2021 12:59:17	Sandy Hayes	nativeprism@yahoo.com	PO Box 886, Kamas, Utah 84036	No	the productions are professional and fabulously entertaining
119	4/7/2021 6:43:24	Connie Shipman	connieshipman61@gmail.com	591 N 200 W Heber, UT 84032	No	We don't live in Midway, but we love going to the plays provided my MAC
120	4/7/2021 7:12:09	Merrie Walker	walkerbeef@gmail.com	1370 S 3350 E Heber, Ut 84032	No	I think it's so surprising that a community our size still does not have a performing arts venue.
121	4/7/2021 7:14:45	Shannon Wilson	callshannonnow@yahoo.com	141 N 400 W	No	I live in Heber, but have a small performing arts group in the county that is Memorial Hill adjacent. I support the arts and preservation of our community's views and open spaces.
122	4/7/2021 8:22:20	Teresa Glenn	tdawnglenn@gmail.com	4725 Palomino Dr, Heber City, UT	No	We love to go every year to performances from High Valley Arts.

	TIME STAMP	NAME	EMAIL ADDRESS	ADDRESS	MIDWAY VOTER	COMMENTS
123	4/7/2021 8:28:31	Laura Jenkins	laurapjenkins1@gmail.com	1813 east Millcreek way SLC, Utah 84106	No	
124	4/7/2021 8:39:45	Dillon Robertson	dillonrobertson1@hotmail.com	2737 E. Water wheel ct. Heber 84032	No	If you build it they will come.
125	4/7/2021 9:28:14	Jennifer Peirce	jpeirce@hotmail.com	1035 W 1060 S, Heber City, UT 84032	No	
126	4/7/2021 9:52:13	Laura Green	outplaying@gmail.com	350 N El Camino Real #61, Encinitas, Ca 92024	No	We lived in Midway for 15 years. We return 3 or 4 times a year & all of summer. We never miss the chance to see the wonderful outdoor plays & wholeheartedly support this proposal.
127	4/7/2021 10:33:17	Carl Piccareta	carl@capicclaw.com	5134 Heather Lane Park City, UT 84098	No	
128	4/7/2021 12:34:51	Doug Green	outplaying@gmail.com	350 N El Camino Real , #61	No	My family lived in Midway 15 years and even currently we come to Midway every summer and spend 2-3 months. We have enjoyed the plays and arts in Midway and would love to have an arts center in beautiful Midway.
129	4/7/2021 15:56:00	Juan Stocker	hansstocker@msn.com	1261 Links Dr	No	
130	4/7/2021 18:55:20	Michelle Gladwin	sgladwin@msn.com	PO Box 1526 Midway UT 84049	No	I live in the town of Interlaken
131	4/8/2021 6:28:19	Camille Woodward	camillejw5@gmail.com	2501 South 320 East Heber City, UT 84032	No	I'm imagining the field where people used to park and ride the shuttle to Swiss Days. That would be a beautiful area for something like this. Midway and Heber need beautiful parks and areas like this!
132	4/8/2021 17:27:32	Meriadoc Van Roosendaal	merryvanroosendaal@gmail.com	P.O. Box 6	No	
133	4/8/2021 18:27:04	Brandon Osmond	Brandonosmond@gmail.com	1290 Oaks circle Heber Ut 84032	No	
134	4/8/2021 18:39:08	Teresa pace	Tawpace@yahoo.com	1455 S. West Hoytsville Rd., Coalville, UT. 84017	No	Love the productions at Midway.
135	4/8/2021 23:31:54	Jeff Kohler	sheffk78@gmail.com	13 E 450 S, Midway, UT 84049	No	
136	4/9/2021 7:11:31	Mylee Beckstrom	Tjzaccardi@gmail.com	1615 east 1050 north Heber	No	Keep theater alive
137	4/9/2021 7:13:51	Nya Beckstrom	tjzaccardi@gmail.com	1615 east 1050 north Heber	No	Don't block memorial hill for future generations, let it stand as the beacon it's always been
138	4/9/2021 17:33:33	Hi McNaughtan	himcnaughtan@hotmail.com	1151 Pine Circle, Heber, Utah 84032	No	Love what you are doing!
139	4/11/2021 10:26:37	Shirene McKay	myvoice2u2@yahoo.com	P.O. Box 784, Lehi Utah 84043	No	Although we don't live in Midway we love attending the productions in Midway.
140	4/15/2021 17:46:58	April Owens	Queenapethegrape@hotmail.com	1997 Fieldstone Ln, Heber City, UT 84032	No	We NEED the MAC!!
141	4/20/21 6:10	Laurisa Pullan	Pullan6@msn.com	967 Garden Dr. Heber, UT. 84032	No	
142	4/20/21 8:36	Nanette Pollard	nanettehp@msn.com	5219 Riata Circle, Oakley UT	No	
143	4/20/21 10:26	Jason Rees	jasonrees29@yahoo.com	856 S 4225 W	No	I look forward and support the Midway arts center.
144	4/20/21 10:55	Sara Penny	sara.penny098@gmail.com	1366 North Fairway, Cedar City, Utah	No	The arts enrich our lives.
145	4/21/21 1:48	Chynna Rowley	sunshine.smile247@yahoo.com	350 S Millers Mile Rd, Heber, UT 84032	No	
146	4/22/21 19:28	Elyse Stuedter	elya_tay@hotmail.com	120 south 200 east Heber	No	I wholeheartedly support the construction of the Midway Arts Center in front of Memorial Hill. This seems like a no-brainer.
147	4/22/21 19:45	Rachael Gull	rachael.rawson@gmail.com	851 Pinion Circle, Heber City, UT 84032	No	The MAC will be such a valuable addition to this community!
148	4/22/21 21:54	Justine Klein	nosenotes@gmail.com	2059 South 500 East, Heber City, Utah	No	I am a Vocal Teacher and a piano teacher here in Heber, and I have students who are involved in theatre and love to perform! I would help them and future students prepare for shows and musicals and I would attend every show and support the arts.
149	4/23/21 9:29	Shannon Banks	shannon.m.banks@gmail.com	6411 Shady Lane, Falls Church VA, 22042	No	

	TIME STAMP	NAME	EMAIL ADDRESS	ADDRESS	MIDWAY VOTER	COMMENTS
150	4/24/21 17:50	Laura Nelson	laurajnelson310@gmail.com	2646 red knob way	No	Moving to midway this fall and hope so much to keep the charm of this special city
151	4/24/21 18:07	Royce alKing	Roycewking@gmail.com	1976 Graystone In	No	
152	4/25/21 8:51	Wayne Braunberger	wbraunberger@gmail.com	2509 East Oak Grove Drive, Sandy, Utah 84092	No	We love High Valley Arts productions. We usually patronize businesses in Midway when we come to see post productions. We also appreciate the open space feel in Midway.
153	4/25/21 12:13	Carol Taylor	Momtay5@yahoo.com	464 No. 680 west Midway, Utah 84049	No	I do pay property tax in Midway.
154	4/25/21 13:11	Shauna Braunberger	Shaunabraunberger@comcast.net	2509 Oak Grove Dr Sandy Ut 84093	No	I visit Midway often because I have family in the plays and that live there.
155	4/25/21 15:16	Shellie Gladwin	sgladwin@msn.com	PO Box 1526	No	We live in Interlaken
156	4/25/21 15:18	Bruce Gladwin	Bdgladwin@msn.com	PO Box 1526	No	I live in Interlaken
157	4/25/21 17:16	Spencer Duncan	spenced10@gmail.com	88w 350s Midway, Utah 84041	No	
158	4/25/21 19:28	Melissa Nock	melissa.nock914@gmail.com	1015 S 900 W, Heber City, UT 84032	No	
159	4/26/21 15:40	Aaron Brandley	aaronbrandley@gmail.com	1008 Cobblestone Dr. Heber	No	
160	4/26/21 19:17	Paul Robertson	Probertson305@gmail.com	2737 Water Wheel Ct, Heber City, UT 84032	No	Our valley needs the MAC!
161	4/26/21 19:20	Zachary Nock	Zach.nock@gmail.com	1015 s 900 w heber city ut 84032	No	
162	4/26/21 19:24	Maile Nielsen	nielsenmaile13@gmail.com	5015 E 1350 S	No	I have participated in a number of plays at High Valley Arts and I absolutely adore this organization and all that it stands for. It has given me a great way to be involved in the community and meet wonderful people that I otherwise would never know.
163	4/27/2021 13:30:27	Michelle Nielsen	michellenielsen.gsglife@gmail.com	5015 E 1350 S Heber City, Ut 84032	No	We can't wait fit this new center to be built
164	4/30/21 9:03	Shelby Osmond	shelbyosmond@gmail.com	368 n 100 w Heber 84032	No	
165	5/3/21 14:14	Lydia Fredericks	lf14876@ms.wasatch.edu	lf14876@ms.wasatch.edu	No	
166	5/4/21 9:28	Merilee Terry	merleete@gmail.com	637 St. Andrews Drive	No	The MOANA jr. play was incredible! It was my grandchildren's first live stage performance and they were enthralled the entire time. We certainly would LOVE to enjoy more family time at the MAC. Please make this happen.
167	5/4/21 9:33	Rhoda Zobel	Rzobel@gmail.com	637 st andrews drive	No	Thank you for all the hard work you have done to create a fantastic venue. We definitely support having MAC nearby and are certain our family would enjoy what it will offer. Please make this a possibility!
168	5/7/21 7:31	Heidi Clark	heidiclark09@hotmail.com	1109 N Chimney Rock Rd , Heber	No	
169	5/12/21 11:15	Bre Gibson	Breezy426@gmail.com	736 east 400 south Heber city	No	
170	5/13/21 13:05	samuel neal	sn18867@ms.wasatch.edu	235 creek place midway utah	No	
171	5/20/21 19:28		Bdgladwin@msn.com	PO Box 1526	No	I live in Interlaken
172	5/24/21 11:44	Juliana Elison	Juliana Elison	817 W 600 S	No	My family lives there and I grew up there. It means a lot to me to preserve the beauty of Main Street.
173	5/24/21 11:59	Jeanette Steadman	Jeanette Steadman	3933 El Lado Dr. La Crescenta, CA 91214	No	Midway should not allow monstrosities like the strip mall proposed. It will lose its specialness and charm.
174	5/24/21 12:15	Becky McAlister	Becky McAlister	5521 S 3800 W Roy, UT 84067	No	My mother is a resident and I plan to move back within the next several year.
175		Chip Hayes	nativeprism@yahoo.com	PO Box 886, Kamas, UT 84036	No	

	TIME STAMP	NAME	EMAIL ADDRESS	ADDRESS	MIDWAY VOTER	COMMENTS
176		Grace Piccarreta	carl@capicclaw.com	5134 Heather Lane Park City, UT 84098	No	
177		Kimberly Baer	ladiekay@gmail.com	920 s Coldwater way midway UT 84049	No	
178		Lynn Robertson	Lrobertson1077@gmail.com	2737 Water Wheel Ct, Heber City, UT 84032	No	
179		Michael Rasmussen	Mikerass2002@gmail.com	4140 Sunrise Drive, Park City Utah 84098	No	
180		Shari Brandley	Shalyn428@yahoo.com	1008 Cobblestone Dr Heber City UT 84032	No	
181	7/5/21 20:01	Jeff Dorius	doriusj@hotmail.com	801 Lake Creek Way. Heber City, UT	No	Communities need to support and hang on to the arts and especially community theater.
182	7/5/21 21:02	Bryson Ritchie	brysonritchie@gmail.com	1909 Chery Ln Heber City, UT 84032	No	
183	7/7/21 14:54	Diana Remington	dskousen@yahoo.com	547 Royal Troon Dr., Heber City, UT 84032	No	Would love to see the MAC and a European-style village with a view of Memorial Hill.
184	7/7/21 16:14	Carla Lake	clake50@icloud.com	2595 E Bumett Ave Louisville KY 40217	No	I visit Utah often and love to visit Midwysy!!
185	7/8/21 20:30	Rob Shallenberger	robshallenberger@gmail.com	1127 Valley View road Heber city UT	No	As a member of the valley, I fully support this project!
186	7/9/21 21:38	Teresa Glenn	tdawnglenn@gmail.com	4725 Palomino Dr, Heber City, UT	No	
187	7/11/21 17:59	Carol Dalton	rcdalton2003@yahoo.com	4389 south	No	
188	7/12/21 19:47	M scott woodruff	mswoodruff.13@gmail.com	1128 s 820 east apt 6203 heber city, ut 84032	No	The arts is what makes life bearable. Supporting a vibrant arts group in the community is worthy of investment and support
189	7/12/21 20:14	Christine Chappell	legomom966@gmail.com	966 E 2810 S Heber	No	
190	7/12/21 21:29	Greta Carse	Gretacarse@gmail.com	246 n millbrook road Heber city Utah	No	
191	7/13/21 19:18	Carla Rosenthal	carlarosenthal@comcast.net	1404 Woodmont Blvd, Nashville, TN 37215	No	A great town deserves a great performing arts center!
192	7/14/21 21:23	Lynnley Robertson	Lj68@hotmail.com	925 w 1200 so	No	What an amazing contribution this would be
193	7/15/21 11:44	Keith Rust	keith@rustfamily.com	4862 W Wexford Way, South Jordan, UT 84009	No	
194	7/15/21 20:16	Hayley Smith	dhkjsmith@yahoo.com	246 N Waterside Rd, Heber	No	
195	7/16/21 15:04	Janet lux	lux_janet@yahoo.com	1070 s 5700 E Heber city	No	Yes to Midway performing arts Center. No more commercial buildings.
196	7/16/21 18:38	Laurel Smith	seelaurelgo@gmail.com	408 E Parkview Circle	No	Not a resident, but regularly visit Midway for family activities.
197	7/17/21 21:29	Sarah Sandstrom	sarah.j.sandstrom@gmail.com	724 W 1720 N apt 212 Provo, UT 84604	No	
198	7/17/21 21:29	Garrett Stephens	garysteves96@gmail.com	613 N 1100 W, Provo, UT, 84601	No	
199	7/18/21 16:50	Susan Anderson	anderport@yahoo.co.uk	1422 N Chimney Rock Road, Heber City, UT 84032	No	
200	7/20/21 12:24	Rachel Freeman	rachel.o.freeman@gmail.com	124 2975 N Lehi	No	
201	7/23/21 10:33	Hank and Kristy Nelson.	hankristy1@hotmail.com	RR 3 Box A 16 Provo Canyon Utah 84604	No	We are patrons of the Arts, and feel this proposal would be a real boon to Heber Valley and all the surrounding areas.
202	7/25/21 9:31	Geidy Hatch	Geidyachecar@gmail.com	1049 N. Meadowcreek Ct, Midway, UT 84049	No	
203		Kami Glick	kamiglick@gmail.com	1071 S Meadow Walk Drive Heber, UT 84032	No	
204		Garrett Glick	glick.garrett@gmail.com	1071 S Meadow Walk Drive	No	

APPENDIX 8 - FINANCIAL BENEFITS

FINANCIAL BENEFITS

- Cultural tourism brings people to Midway willing to spend money at local restaurants, stores, gas stations, resorts, and other businesses.
- The following Victus Advisors Study gives the details.



DRAFT COPY

Subject to Change



Heber Valley

FEASIBILITY STUDY FOR THE PROPOSED
HEBER VALLEY COMMUNITY ARTS CENTER

DRAFT V3 - MARCH 27, 2018



VICTUS
ADVISORS

ESTIMATED NET IMPACTS OVER 30 YEARS*

<u>Year</u>	<u>Direct Spending</u>	<u>Total Output</u>	<u>Employment</u>	<u>Wages</u>	<u>Local Tax Revenue</u>
1	\$12,227,700	\$17,697,930	173	\$7,108,018	\$72,369
2	2,620,505	3,895,460	63	1,012,490	55,468
3	2,699,121	4,012,324	63	1,042,865	57,132
4	2,780,094	4,132,694	63	1,074,151	58,846
5	2,863,497	4,256,674	63	1,106,375	60,612
6	2,949,402	4,384,375	63	1,139,566	62,430
7	3,037,884	4,515,906	63	1,173,753	64,303
8	3,129,020	4,651,383	63	1,208,966	66,232
9	3,222,891	4,790,924	63	1,245,235	68,219
10	3,319,578	4,934,652	63	1,282,592	70,265
11	3,419,165	5,082,692	63	1,321,070	72,373
12	3,521,740	5,235,172	63	1,360,702	74,545
13	3,627,392	5,392,228	63	1,401,523	76,781
14	3,736,214	5,553,995	63	1,443,569	79,084
15	3,848,301	5,720,614	63	1,486,876	81,457
16	3,963,750	5,892,233	63	1,531,482	83,901
17	4,082,662	6,069,000	63	1,577,426	86,418
18	4,205,142	6,251,070	63	1,624,749	89,010
19	4,331,296	6,438,602	63	1,673,492	91,680
20	4,461,235	6,631,760	63	1,723,696	94,431
21	4,595,072	6,830,713	63	1,775,407	97,264
22	4,732,924	7,035,634	63	1,828,670	100,182
23	4,874,912	7,246,703	63	1,883,530	103,187
24	5,021,159	7,464,104	63	1,940,036	106,283
25	5,171,794	7,688,027	63	1,998,237	109,471
26	5,326,948	7,918,668	63	2,058,184	112,755
27	5,486,756	8,156,228	63	2,119,929	116,138
28	5,651,359	8,400,915	63	2,183,527	119,622
29	5,820,900	8,652,942	63	2,249,033	123,211
30	5,995,527	8,912,531	63	2,316,504	126,907
Cumulative Total:	\$130,724,000	\$193,846,000	63	\$52,892,000	\$2,581,000
Net Present Value:	\$73,330,000	\$108,547,000	n/a	\$30,625,000	\$1,373,000

* Includes both one-time construction impacts (allocated to Year 1) and annual operations impacts (adjusted annually for inflation).
 Note: Assumes annual inflation of 3.0% and discount rate of 4.0%.

TOTAL IMPACTS (NET)

Over a 30 year period, a new Community Arts Center is estimated to have a total net impact of nearly \$194 million in cumulative net economic output and almost \$2.6 million in net local sales, restaurant, and hotel tax revenues.

CONCLUDING OBSERVATIONS

NOTABLE FACTS

- HVAF has a 15-year positive financial track record and has never operated in the red.
- 10,500 people saw HVAF shows last year.
- "Sound of Music" has sold out every night thus far!
- 4,500 people saw last year's sold-out "Seven Brides" performances.



NOTABLE FACTS

- 2/3 of the 174 kids who auditioned for “Lion King Jr” did not get a role in the show.
- Once HVAF has a home, children will have increased performing opportunities.
- HVAF involves more people in events than does any other Midway group except Swiss Days.



THE ALTERNATIVE TO THE MAC

- The current property owner (Devin Johnson) has stated his intention to develop the proposed site ASAP. His preferred option is to support The MAC. If not The MAC, his lead option would be a commercial building that is 35' tall with a 10' set-back (allowed in C2).



WHAT DO WE WANT OUR LEGACY TO BE?





Midway

ORDINANCE

2022-_____

AN ORDINANCE TO AMEND CERTAIN SECTIONS OF THE MIDWAY CITY LAND USE CODE TO ADD INDOOR PERFORMING ARTS CENTERS AS A CONDITIONAL USE IN THE C-2 ZONE.

WHEREAS, pursuant to Utah Code Section 10-9a-509 the Midway City Council may formally initiate proceedings to amend city ordinances; and

WHEREAS, Section 16.5.2 of the Midway City Land Use Code establishes permitted and conditional uses within the C-2 and C-3 zones of the City; and

WHEREAS, Midway City desires to add indoor performing arts centers as a conditional use in the C-2 zone; and

WHEREAS, Midway City also desires to amend Sections 16.13.10 and 12.11.020 to include indoor performing arts centers in lists of structures allowed to exceed stated height restrictions.

NOW THEREFORE, be it ordained by the City Council of Midway City, Utah, as follows:

Section 16.5.2(B) shall be amended to read as follows:

B. In the following list of possible uses in the C-2 and C-3 zones, those designated “P” will be a permitted use. Uses designated as “C” will only be allowed when approved as a conditional use by the City Council. Uses designated as “N” will not be allowed in the zone.

USES	C-2	C-3
Retail, grocery, and service stores (up to 25,000 sq. ft.) Tobacco sales and e-cigarettes (no more than 5% of total retail)	P	P
Professional offices and clinics	P	P
Auto detailing, gas stations and car washes	C	N

Alcohol dispensing establishments (with local consent)	C	C
Rest Homes/Nursing/Convalescent Facilities/Assisted Living	P	P
Day Care	P	P
Recreational activity businesses, photo, art, and craft galleries, retail show rooms	P	P
Engraving, publishing, and printing	P	P
Mortuaries and wedding chapels	P	P
New and used vehicle sales and rentals	C	N
Hospitals	P	P
Short-term lodging facilities	P	P
Cafes and restaurants	P	P
Public and quasi-public buildings (police/fire stations)	P	P
Barber, beauty shops, massage therapy and day spas	P	P
Vehicle parking (not associated with another use)	C	C
Repair shops (other than auto) (no outside storage)	P	P
Veterinarian and pet grooming services (no outside kennels or keeping of animals)	P	P
Mixed Use (See Section 16.5.3(I))	C	C
Commercial PUDs and commercial condominium projects	C	C
Private academies/studios (education, art, dance, sports, etc.)	P	P
Carpentry and woodworking shops (no outside storage)	C	C
Electrician shops (no outside storage)	P	P
Plumbing shops (no outside storage)	P	P
Residential Condos in Mixed Use Projects	C	C
Residential accessory structures (no living or sleeping space)	P	P
Commercial accessory structures	P (Conditional if associated with a conditional use)	P (Conditional if associated with a conditional use)
Internal Accessory Dwelling Unit	P	P
Indoor Performing Arts Centers	C	C

Section 16.13.10(E) shall be amended to read as follows:

- E. Public buildings, **indoor performing arts centers**, and churches may be erected to any height provided the building is set back from required building setback lines a distance of at least one (1) foot for each additional foot of building height above the maximum height permitted.

Section 12.11.020(D) shall be amended to read as follows:

- D. Public buildings, **indoor performing arts centers**, and churches may be erected to any height provided the building is set back from required building setback lines a distance of at least one (1) foot for each additional foot of building height above the maximum height permitted.

This ordinance shall take effect upon publication as required by law.

DRAFT
///
///

PASSED AND ADOPTED by the City Council of Midway City, Wasatch County, Utah
this ____ day of _____, 2022.

	AYE	NAY
Council Member Steve Dougherty	_____	_____
Council Member Jeff Drury	_____	_____
Council Member Lisa Orme	_____	_____
Council Member Kevin Payne	_____	_____
Council Member JC Simonsen	_____	_____

DRAFT

APPROVED:

Celeste Johnson, Mayor

ATTEST:

Brad Wilson, City Recorder

APPROVED AS TO FORM:

Corbin Gordon, City Attorney

(SEAL)