

Midway City Council
7 September 2021
Regular Meeting

Rising Ranch Subdivision /
Revised Final Approval

Memo



Date: September 7, 2021
To: Midway City Council
From: Michael Henke
Re: Revised Final Approval for Rising Ranch Subdivision

Sam Castor, agent for Bow Hunting Skills LLC, is requesting revised final approval of an 8-lot subdivision known as Rising Ranch. No subdivision plat has been recorded; this approval would amend the previous approval.

Mr. Castor has requested that his previous approval is amended to combine lots 3 and 4 into one 1.199-acre lot. No other changes to the development or its approval are proposed.

The City Council should consider if the proposal is in the best interest of the community and if the adjustment matches the vision of Midway as described in the General Plan. The General Plan describes, among many things, the preservation of open space and the rural atmosphere of Midway. This proposal seems to help reach those two goals by eliminating one lot from the subdivision plat. Lowering the density reduces the impact of development on the community by reducing potential services required by a developed lot, traffic (on average about ten trips per day) and potential impact on the school district.

The applicant, and future lot owner of the combined lot, would benefit from reduced property taxes if the two lots are combined into one. The lot would also qualify for animal rights since it would be over an acre in size.

In the August 17th City Council meeting, there was a concern with the newly combined lot having two driveway accesses, one on Homestead Drive and one on Swiss Alpine Road. The applicant has been approved by both Midway City and UDOT to combine the driveways for four lots that front onto Homestead Drive into two shared driveway accesses. The existing home on the property has two existing accesses for its driveway, which would be reused for the two shared driveway access points. If the amendment is approved, it is anticipated that both access

points would be utilized allowing the proposed combined lot to have access from Homestead Drive.

The land use code regulates motor vehicle access as follows in 16.13.21 – MOTOR VEHICLE ACCESS:

Access to all lots and parcels of land having frontage on a public street shall be controlled as follows:

A. Access shall be by not more than two driveways from any one street, except as may be permitted by the City Council, when it can be shown that additional driveways will promote traffic safety.

B. On corner lots, no driveway shall be closer than 40 feet to the point of intersection of the front property line with the side property line which abuts upon a street.

Additionally, the Midway City Capital Facility Plan states that driveway spacing is a minimum of 100' on local streets like Swiss Alpine Road. The proposed lot would have approximately 220' of frontage along Swiss Alpine Road. As long as the applicant can meet the above criteria, staff sees no problem with there being an access along both streets.

Below is the motion of approval along with the findings and conditions as noted in the draft minutes for the 7/20/2021 city council meeting. If the proposed combining of lots 3 and 4 is approved, staff would suggest removing the first condition which limits access from lot 3 directly onto Homestead Drive.

Motion: Council Member Dougherty moved to grant final approval to the Rising Ranch Subdivision as presented with the following findings and conditions:

Findings:

- The proposal met the intent of the General Plan for the R-1-22 zone.
- The proposal complied with the land use requirements of the R-1-22 zone.
- A public trail would be built as part of the subdivision that would benefit members of the community.
- 0.956 acres of open space would be created as part of the development.
- The Homestead Drive half width adjacent to the development would be widened to 26 feet.
- The duration of final approval would be for one year from the date of final approval of the development by the City Council. Should a final plat not be recorded by the County Recorder within the one-year period of time, the development's approval would be voided, and both preliminary and final approvals would have to be re-obtained, unless, on a showing of extenuating circumstances, the City Council extended the time limit for plat recording, with or without conditions.

Conditions:

- A plat note would be included that precluded access to lot three from Homestead Drive.

- Funds to build the five-foot bike lane along Homestead Drive adjacent to this project would be added to the general trails fund and would be used when the bike lane was completed in the future as part of a larger improvement project.
- The plat and development agreement would clearly state that parcel eight was not currently considered a building lot and what needed to occur for the parcel to become buildable. This would include at a minimum the need for additional planning approval, possibly amending the development agreement, obtaining a minimum of 115 feet of frontage along a road built to city standards, lot improvements that included a sewer connection, culinary water connection, irrigation connection, adequate access to a fire hydrant, etc.
- The trail easement along Swiss Alpine Road would be a minimum of 15 feet wide.
- A different name would be used on the plat map for the area shown as open space.

Second: Council Member Payne seconded the motion.

Discussion: None

Vote: The motion was approved with the Council voting as follows:

Council Member Dougherty Aye

Council Member Drury Excused from the Meeting

Council Member Orme Aye

Council Member Payne Aye

Council Member Simonsen Aye



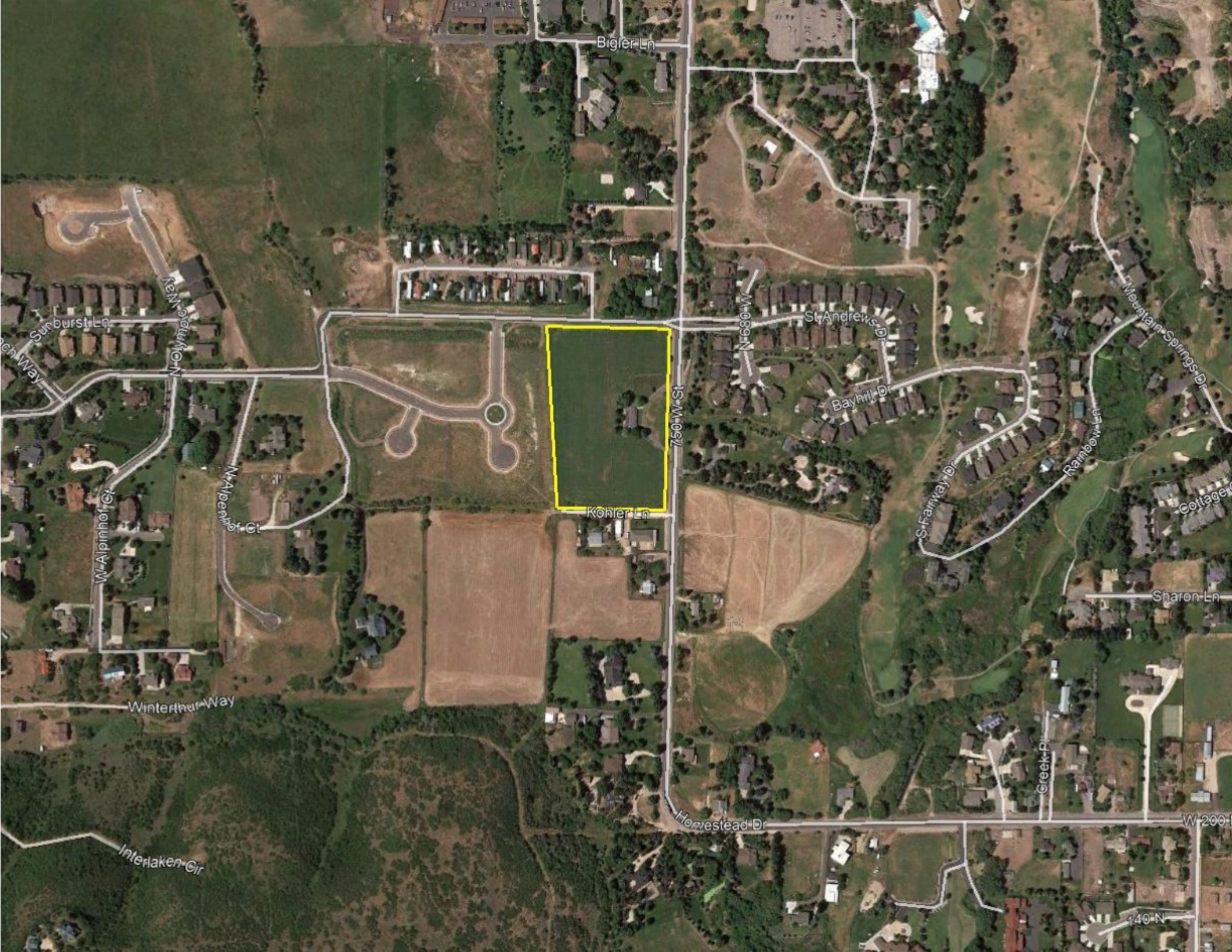

Bigler Ln

750 W St

Kohler Ln

St Andrews Dr

Bayhill Dr

S Farway Dr

Rambow Ln

Sharon Ln

Homestead Dr

W 200

Creek Pl

Winterthur Way

W Alpinhof Ct

N Alpinhof Ct

N Nymble

Conburst Ln

Interlaken Cir

140° N

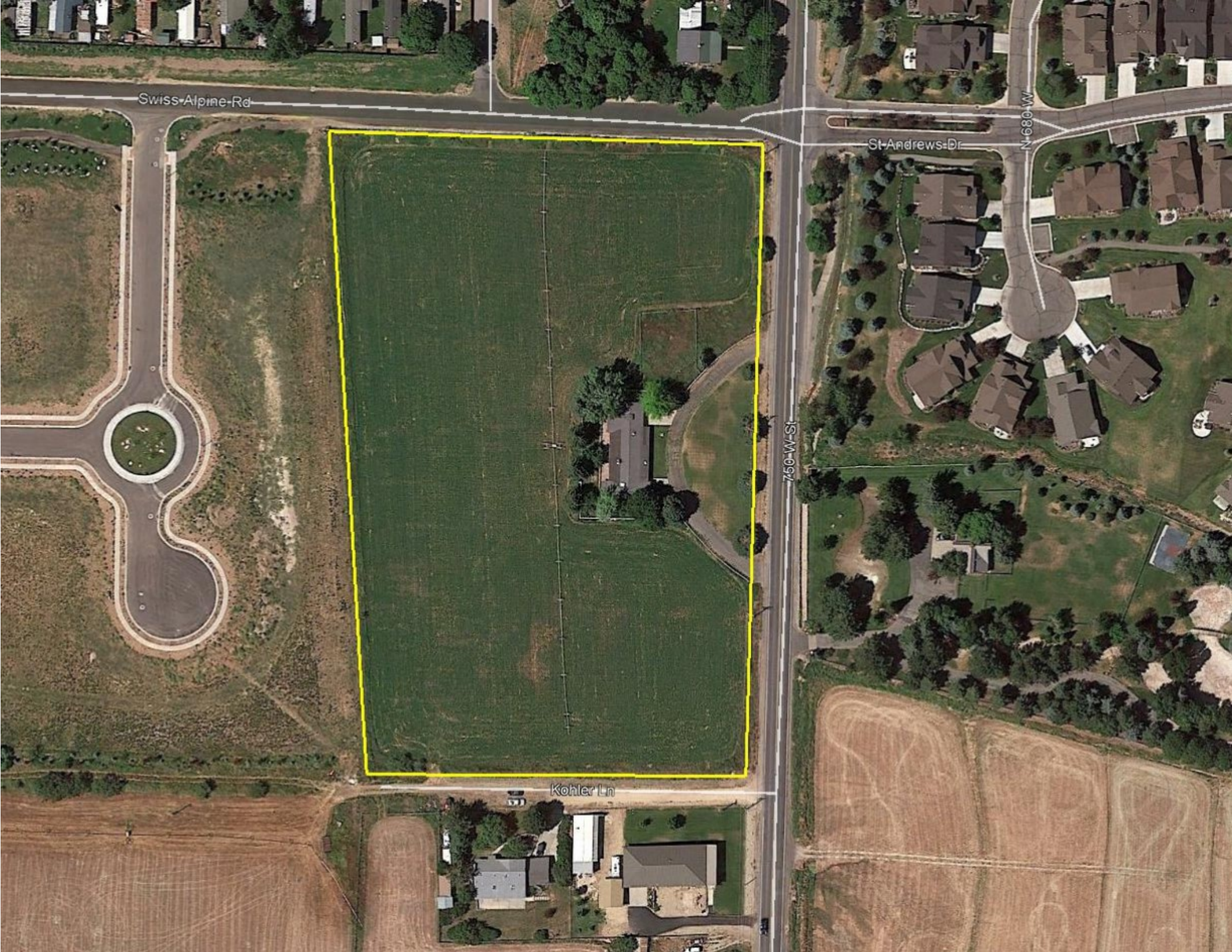

Swiss-Alpine-Rd

St-Andrews-Dr

N-680-W

750-W-St

Kohler Ln

Exhibits

Exhibit 1 – Approved Plat

Exhibit 2 – Proposed Plat

Exhibit 1

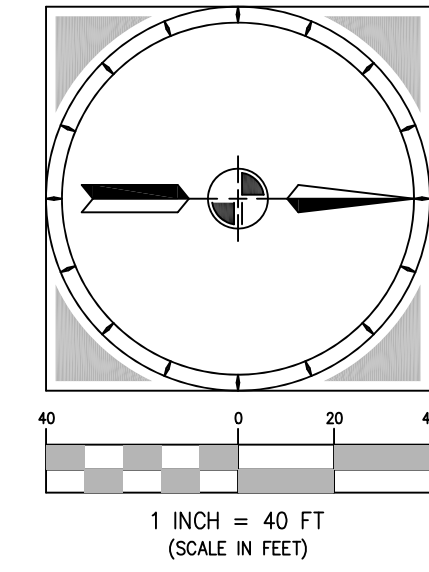
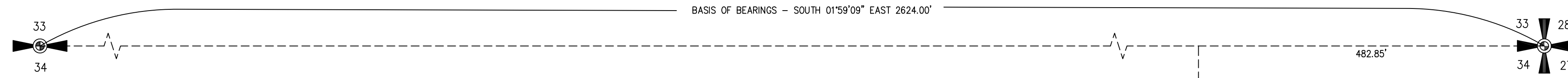

XXX HOMESTEAD DRIVE

LEGEND

- SET STREET MONUMENT
- BOUNDARY ANGLE POINT
- DRIVEWAY EASEMENT
- DEDICATED TO CITY

NOTES

PUBLIC UTILITY EASEMENTS:

ALL LOTS IN THIS SUBDIVISION ARE SUBJECT TO PUBLIC UTILITY EASEMENTS ALONG ALL PROPERTY LINES AS FOLLOWS:
 FRONT: 10 FEET
 REAR: 10 FEET
 SIDE: 5 FEET

ZONING INFORMATION

APPROVED MINIMUM SETBACKS ARE AS FOLLOWS:
 FRONT: 30 FEET
 REAR: 30 FEET
 SIDE: 12 FEET MINIMUM 28 FEET COMBINED

THE 100 FOOT SETBACK ALONG HOMESTEAD DRIVE IS APPLICABLE TO ALL STRUCTURES, RESIDENTIAL AND ACCESSORY.

CORNER LOTS ARE SUBJECT TO A 30 FOOT BUILDING SETBACK ON THE STREET THAT IS NOT BEING FRONTED ON. ALL SETBACKS ARE SUBJECT TO HEBER CITY ZONING ORDINANCE REQUIREMENTS AT THE TIME A BUILDING PERMIT IS ISSUED.

TYPICAL LOT DIAGRAM

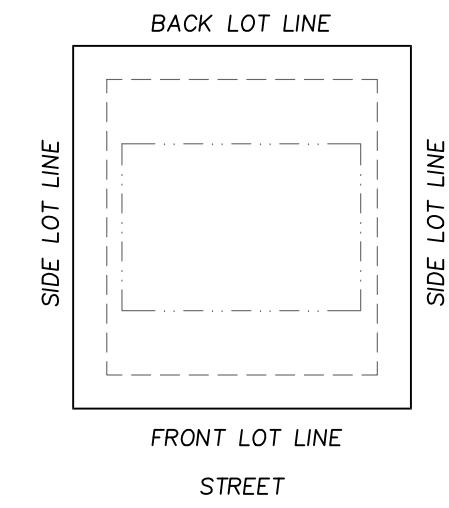

VICINITY MAP

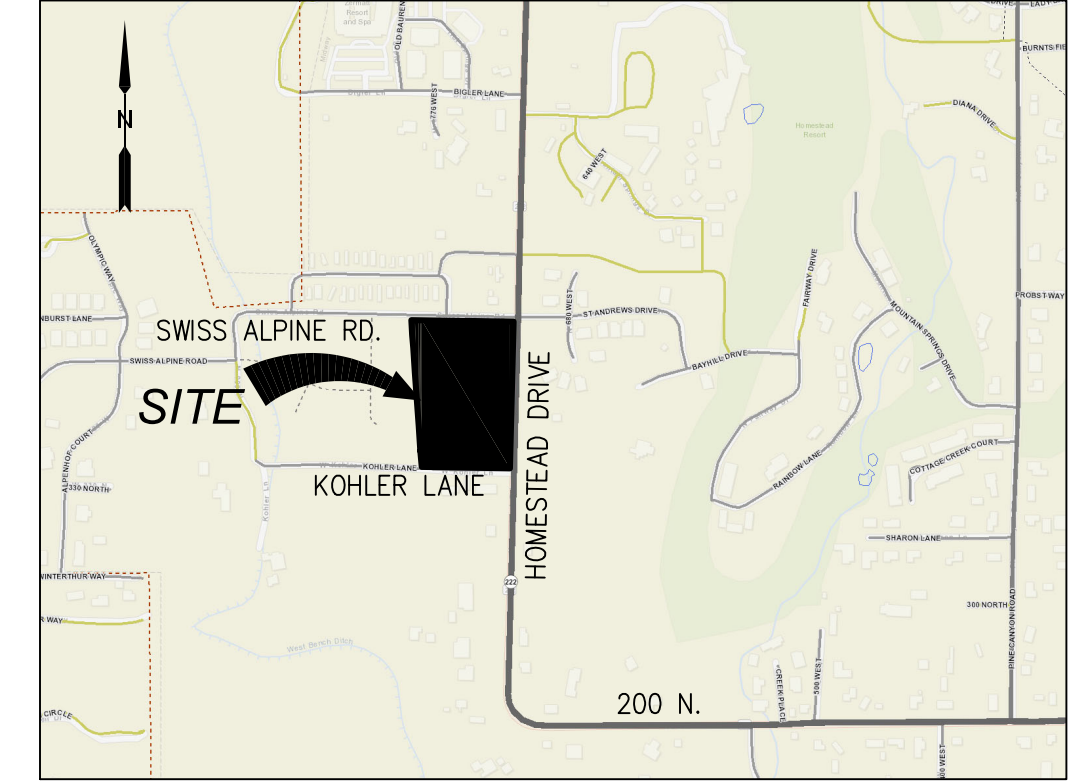

BOUNDARY DESCRIPTION

BEGINNING AT THE 1996 WASATCH COUNTY MONUMENT REPRESENTING THE NORTHWEST CORNER OF SECTION 34, TOWNSHIP 3 SOUTH, RANGE 4 EAST, SALT LAKE BASE AND MERIDIAN; THENCE SOUTH 01°59'09" EAST 482.85 FEET AND EAST 519.94 FEET TO THE POINT OF BEGINNING; SAID POINT OF BEGINNING BEING AN EXISTING FENCE CORNER AND A FOUND REBAR AND CAP REPRESENTING THE NORTHEAST CORNER OF THE MAISONS DE SAINT PREX SUBDIVISION RECORDED AS ENTRY NUMBER 451841 OF THE OFFICIAL RECORDS OF WASATCH COUNTY.

THENCE ALONG AN EXISTING FENCE AND THE SOUTH LINE OF SWISS ALPINE ROAD SOUTH 89°12'00" EAST 455.14 FEET TO THE WEST RIGHT-OF-WAY LINE OF HOMESTEAD DRIVE (SR 222); THENCE ALONG SAID WEST RIGHT-OF-WAY LINE SOUTH 01°51'31" WEST 134.72 FEET AND SOUTH 01°18'24" WEST 519.01 FEET TO THE NORTH BOUNDARY LINE OF THE VARVEL PROPERTY AS RECORDED IN A WARRANTY DEED AS ENTRY NUMBER 281933 OF SAID OFFICIAL RECORDS; THENCE ALONG AN EXISTING FENCE AND SAID VARVEL PROPERTY NORTH BOUNDARY NORTH 89°06'25" WEST 392.62 FEET TO A FOUND REBAR AND CAP REPRESENTING THE SOUTHWEST CORNER OF SAID MAISONS DE SAINT PREX SUBDIVISION; THENCE ALONG AN EXISTING FENCE AND ALONG THE EASTERLY BOUNDARY OF SAID MAISONS DE SAINT PREX SUBDIVISION THE FOLLOWING 6 COURSES; NORTH 04°48'44" WEST 71.55 FEET, NORTH 03°47'59" WEST 111.25 FEET, NORTH 04°10'49" WEST 236.27 FEET, NORTH 03°38'16" WEST 111.85 FEET, NORTH 04°40'08" WEST 57.10 FEET AND NORTH 03°22'55" WEST 67.40 FEET TO THE POINT OF BEGINNING.

PARCEL CONTAINS 6.36 ACRES.

BASIS OF BEARINGS

THE BASIS OF BEARINGS FOR THIS SURVEY WAS ESTABLISHED AS SOUTH 01°59'09" EAST 2624.00 FEET BETWEEN COUNTY MONUMENTS REPRESENTING THE NORTHWEST CORNER AND THE WEST ONE-QUARTER CORNER OF SECTION 34, TOWNSHIP 3 SOUTH, RANGE 4 EAST, SALT LAKE BASE AND MERIDIAN IN CONFORMANCE WITH UTAH COORDINATE SYSTEM 1983 CENTRAL ZONE BEARINGS.

SURVEYOR'S CERTIFICATE

IN ACCORDANCE WITH SECTION 10-9a-603 OF THE UTAH CODE, I, BRIAN BALLS, DO HEREBY CERTIFY THAT I AM A PROFESSIONAL LAND SURVEYOR HOLDING LICENSE NUMBER 334532-2201 IN ACCORDANCE WITH TITLE 58, CHAPTER 22, OF THE PROFESSIONAL ENGINEERS AND PROFESSIONAL LAND SURVEYORS LICENSING ACT.

I FURTHER CERTIFY THAT I HAVE COMPLETED A SURVEY OF THE PROPERTY DESCRIBED ON THE PLAT IN ACCORDANCE WITH SECTION 17-23-17 OF THE UTAH CODE, AND HAVE VERIFIED ALL MEASUREMENTS, AND HAVE PLACED MONUMENTS AS REPRESENTED ON THE PLAT.

BRIAN BALLS _____ DATE _____
 PROFESSIONAL LAND SURVEYOR SURVEYOR'S SEAL

OWNER'S DEDICATION

KNOW ALL MEN BY THESE PRESENTS THAT I (WE) THE UNDERSIGNED OWNER(S) OF THE TRACT(S) OF LAND SHOWN AND DESCRIBED ON THIS SUBDIVISION PLAT, HAVE CAUSED THE SAME TO BE SUBDIVIDED INTO LOTS, STREETS, AND EASEMENTS, INCLUDING PUBLIC TRAIL EASEMENTS, TO BE HEREAFTER KNOWN AS THE RISING RANCH SUBDIVISION, DO HEREBY DEDICATE FOR THE PERPETUAL USE OF THE PUBLIC ALL PARCELS OF LAND SHOWN ON THIS PLAT AS INTENDED FOR PUBLIC USE.

IN WITNESS THEREOF, I HAVE HEREUNTO SET MY HAND THIS _____ DAY OF _____, 2021.

_____ FEE OWNER (OR AGENT) _____ PRINTED NAME

ACKNOWLEDGEMENT

STATE OF _____)
 COUNTY OF _____) S.S.

ON THIS _____ DAY OF _____, 2021, PERSONALLY APPEARED BEFORE ME, THE UNDERSIGNED NOTARY PUBLIC, IN AND FOR SAID COUNTY OF _____, IN SAID STATE OF _____, THE SIGNER OF THE ABOVE OWNER'S DEDICATION, WHO AFTER BEING DULY SWORN, ACKNOWLEDGED TO ME THAT HE SIGNED THE OWNER'S DEDICATION FREELY AND VOLUNTARILY FOR AND IN BEHALF OF SAID CORPORATION FOR THE PURPOSES MENTIONED AND THAT SAID CORPORATION EXECUTED THE SAME.

_____ NOTARY PUBLIC

ACCEPTANCE BY MIDWAY CITY

THE CITY COUNCIL OF MIDWAY CITY, WASATCH COUNTY, STATE OF UTAH, HEREBY APPROVES THIS SUBDIVISION AND ACCEPTS THE DEDICATION OF LOTS, EASEMENTS, STREETS AND PUBLIC RIGHTS-OF-WAY HEREON SHOWN.

APPROVED: MAYOR _____ DATE _____ ATTEST: CITY RECORDER _____ DATE _____
 APPROVED: CITY ENGINEER _____ DATE _____ ATTEST: CITY ATTORNEY _____ DATE _____
 (SEE SEAL BELOW)

MIDWAY SANITATION DISTRICT

CHAIRMAN _____ DATE _____

MIDWAY IRRIGATION COMPANY

CHAIRMAN _____ DATE _____

WASATCH COUNTY SURVEYOR

APPROVED AS TO FORM _____
 SURVEYOR _____ DATE _____ ROS # _____

WASATCH COUNTY RECORDER

PROJECT C20-020
 SHEET 1
 ISSUE DATE 6/8/2021

Summit Engineering Group Inc.
 Structural • Civil • Surveying
 55 WEST CENTER • P.O. BOX 1716
 HEBER CITY, UTAH 84032
 P: 435-854-9229 • F: 435-854-9231

Developer
 Sam Castor
 702-371-0724
 scastor@gmail.com

COPYRIGHT © 2021
 SUMMIT ENGINEERING GROUP, INC.

WARNING/ALLEGATION
 IT IS A VIOLATION OF LAW FOR ANY PERSON UNLESS ACTING UNDER THE DIRECTION OF THE PROFESSIONAL LAND SURVEYOR TO ALTER ANY ITEM ON THIS DOCUMENT IN ANY MANNER. ANY LICENSEE WHO ALTERS THIS DOCUMENT IS REQUIRED BY LAW TO ATTEST THEIR SEAL AND THE NOTATION "ALTERED BY" FOLLOWED BY THEIR SIGNATURE AND SPECIFIC DESCRIPTION OF THE ALTERATIONS.

RISING RANCH SUBDIVISION PLAT

LOCATED IN THE NORTHWEST 1/4 OF SECTION 34, TOWNSHIP 3 SOUTH, RANGE 4 EAST, SLB&M, MIDWAY, WASATCH COUNTY, UTAH

CITY ENGINEER SEAL _____
 CLERK-RECORDER SEAL _____

Exhibit 2

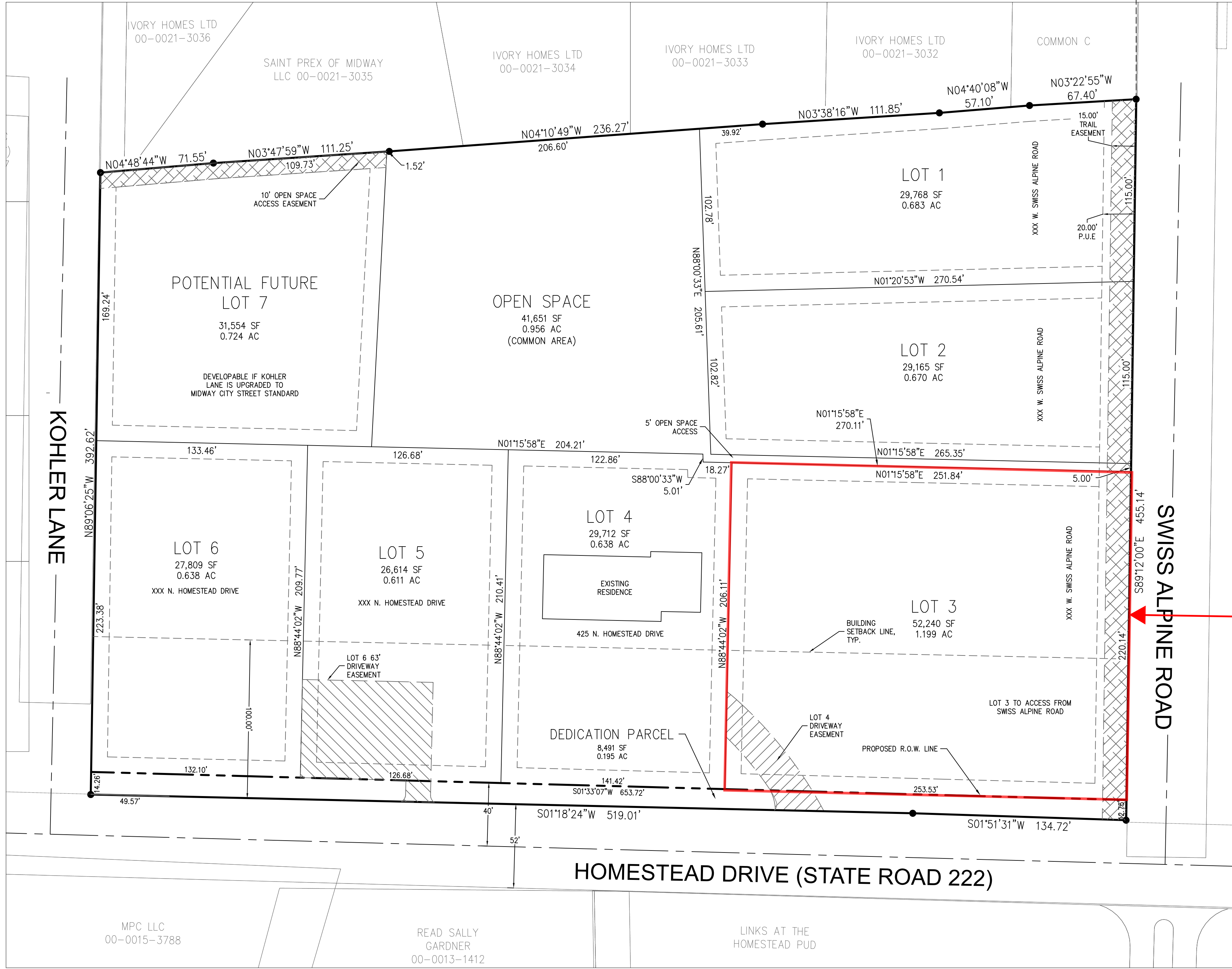
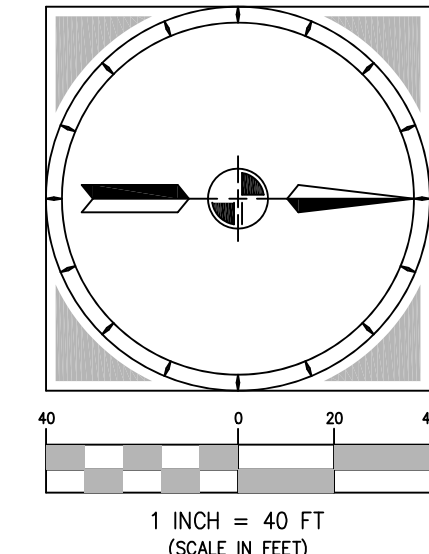
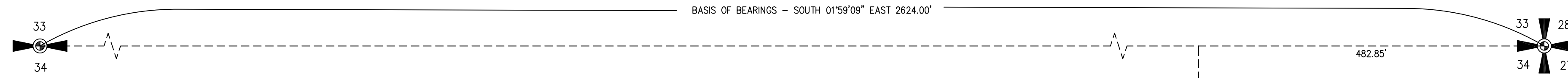

XXX HOMESTEAD DRIVE

LEGEND

- SET STREET MONUMENT
- BOUNDARY ANGLE POINT
- DRIVEWAY EASEMENT
- DEDICATED TO CITY

NOTES

PUBLIC UTILITY EASEMENTS:

ALL LOTS IN THIS SUBDIVISION ARE SUBJECT TO PUBLIC UTILITY EASEMENTS ALONG ALL PROPERTY LINES AS FOLLOWS:
 FRONT: 10 FEET
 REAR: 10 FEET
 SIDE: 5 FEET

ZONING INFORMATION

APPROVED MINIMUM SETBACKS ARE AS FOLLOWS:
 FRONT: 30 FEET
 REAR: 30 FEET
 SIDE: 12 FEET MINIMUM 28 FEET COMBINED

THE 100 FOOT SETBACK ALONG HOMESTEAD DRIVE IS APPLICABLE TO ALL STRUCTURES, RESIDENTIAL AND ACCESSORY.

CORNER LOTS ARE SUBJECT TO A 30 FOOT BUILDING SETBACK ON THE STREET THAT IS NOT BEING FRONTED ON. ALL SETBACKS ARE SUBJECT TO HEBER CITY ZONING ORDINANCE REQUIREMENTS AT THE TIME A BUILDING PERMIT IS ISSUED.

TYPICAL LOT DIAGRAM

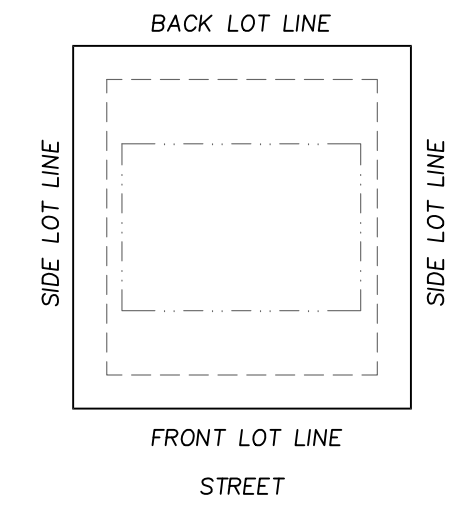

VICINITY MAP

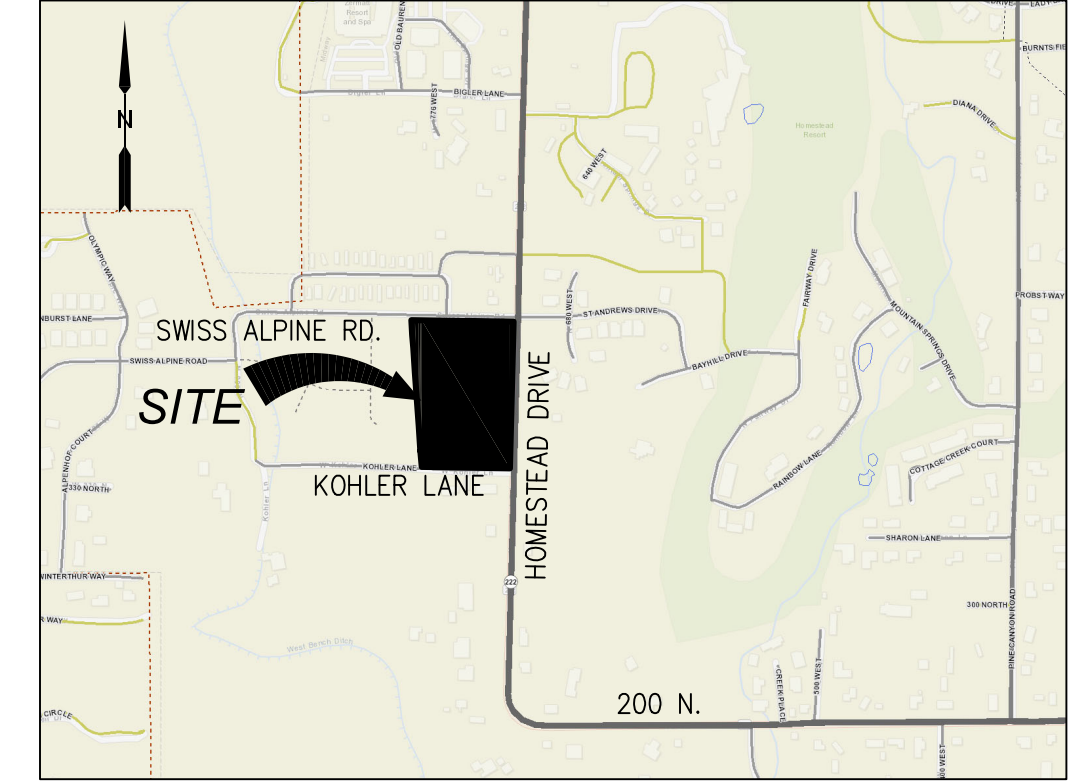

Adjusted Lot

BOUNDARY DESCRIPTION

BEGINNING AT THE 1996 WASATCH COUNTY MONUMENT REPRESENTING THE NORTHWEST CORNER OF SECTION 34, TOWNSHIP 3 SOUTH, RANGE 4 EAST, SALT LAKE BASE AND MERIDIAN; THENCE SOUTH 01°59'09" EAST 482.85 FEET AND EAST 519.94 FEET TO THE POINT OF BEGINNING; SAID POINT OF BEGINNING BEING AN EXISTING FENCE CORNER AND A FOUND REBAR AND CAP REPRESENTING THE NORTHEAST CORNER OF THE MAISONS DE SAINT PREX SUBDIVISION RECORDED AS ENTRY NUMBER 451841 OF THE OFFICIAL RECORDS OF WASATCH COUNTY.

THENCE ALONG AN EXISTING FENCE AND THE SOUTH LINE OF SWISS ALPINE ROAD SOUTH 89°12'00" EAST 455.14 FEET TO THE WEST RIGHT-OF-WAY LINE OF HOMESTEAD DRIVE (SR 222); THENCE ALONG SAID WEST RIGHT-OF-WAY LINE SOUTH 01°51'31" WEST 134.72 FEET AND SOUTH 01°18'24" WEST 519.01 FEET TO THE NORTH BOUNDARY LINE OF THE VARVEL PROPERTY AS RECORDED IN A WARRANTY DEED AS ENTRY NUMBER 281933 OF SAID OFFICIAL RECORDS; THENCE ALONG AN EXISTING FENCE AND SAID VARVEL PROPERTY NORTH BOUNDARY NORTH 89°06'25" WEST 392.62 FEET TO A FOUND REBAR AND CAP REPRESENTING THE SOUTHWEST CORNER OF SAID MAISONS DE SAINT PREX SUBDIVISION; THENCE ALONG AN EXISTING FENCE AND ALONG THE EASTERLY BOUNDARY OF SAID MAISONS DE SAINT PREX SUBDIVISION THE FOLLOWING 6 COURSES; NORTH 04°48'44" WEST 71.55 FEET, NORTH 03°47'59" WEST 111.25 FEET, NORTH 04°10'49" WEST 236.27 FEET, NORTH 03°38'16" WEST 111.85 FEET, NORTH 04°40'08" WEST 57.10 FEET AND NORTH 03°22'55" WEST 67.40 FEET TO THE POINT OF BEGINNING.

PARCEL CONTAINS 6.36 ACRES.

BASIS OF BEARINGS

THE BASIS OF BEARINGS FOR THIS SURVEY WAS ESTABLISHED AS SOUTH 01°59'09" EAST 2624.00 FEET BETWEEN COUNTY MONUMENTS REPRESENTING THE NORTHWEST CORNER AND THE WEST ONE-QUARTER CORNER OF SECTION 34, TOWNSHIP 3 SOUTH, RANGE 4 EAST, SALT LAKE BASE AND MERIDIAN IN CONFORMANCE WITH UTAH COORDINATE SYSTEM 1983 CENTRAL ZONE BEARINGS.

SURVEYOR'S CERTIFICATE

IN ACCORDANCE WITH SECTION 10-9a-603 OF THE UTAH CODE, I, BRIAN BALLS, DO HEREBY CERTIFY THAT I AM A PROFESSIONAL LAND SURVEYOR HOLDING LICENSE NUMBER 334532-2201 IN ACCORDANCE WITH TITLE 58, CHAPTER 22, OF THE PROFESSIONAL ENGINEERS AND PROFESSIONAL LAND SURVEYORS LICENSING ACT.

I FURTHER CERTIFY THAT I HAVE COMPLETED A SURVEY OF THE PROPERTY DESCRIBED ON THE PLAT IN ACCORDANCE WITH SECTION 17-23-17 OF THE UTAH CODE, AND HAVE VERIFIED ALL MEASUREMENTS, AND HAVE PLACED MONUMENTS AS REPRESENTED ON THE PLAT.

 BRIAN BALLS
 PROFESSIONAL LAND SURVEYOR

 DATE

 SURVEYOR'S SEAL

OWNER'S DEDICATION

KNOW ALL MEN BY THESE PRESENTS THAT I (WE) THE UNDERSIGNED OWNER(S) OF THE TRACT(S) OF LAND SHOWN AND DESCRIBED ON THIS SUBDIVISION PLAT, HAVE CAUSED THE SAME TO BE SUBDIVIDED INTO LOTS, STREETS, AND EASEMENTS, INCLUDING PUBLIC TRAIL EASEMENTS, TO BE HEREAFTER KNOWN AS THE RISING RANCH SUBDIVISION, DO HEREBY DEDICATE FOR THE PERPETUAL USE OF THE PUBLIC ALL PARCELS OF LAND SHOWN ON THIS PLAT AS INTENDED FOR PUBLIC USE.

IN WITNESS THEREOF, I HAVE HEREUNTO SET MY HAND THIS _____ DAY OF _____, 2021.

 FEE OWNER (OR AGENT)

 PRINTED NAME

ACKNOWLEDGEMENT

STATE OF _____ }
 COUNTY OF _____ } S.S.

ON THIS _____ DAY OF _____, 2021, PERSONALLY APPEARED BEFORE ME, THE UNDERSIGNED NOTARY PUBLIC, IN AND FOR SAID COUNTY OF _____, IN SAID STATE OF _____, THE SIGNER OF THE ABOVE OWNER'S DEDICATION, WHO AFTER BEING DULY SWORN, ACKNOWLEDGED TO ME THAT HE SIGNED THE OWNER'S DEDICATION FREELY AND VOLUNTARILY FOR AND IN BEHALF OF SAID CORPORATION FOR THE PURPOSES MENTIONED AND THAT SAID CORPORATION EXECUTED THE SAME.

 NOTARY PUBLIC

ACCEPTANCE BY MIDWAY CITY

THE CITY COUNCIL OF MIDWAY CITY, WASATCH COUNTY, STATE OF UTAH, HEREBY APPROVES THIS SUBDIVISION AND ACCEPTS THE DEDICATION OF LOTS, EASEMENTS, STREETS AND PUBLIC RIGHTS-OF-WAY HEREON SHOWN.

APPROVED: MAYOR _____ DATE _____ ATTEST: CITY RECORDER _____ DATE _____
 (SEE SEAL BELOW)

APPROVED: CITY ENGINEER _____ DATE _____ ATTEST: CITY ATTORNEY _____ DATE _____
 (SEE SEAL BELOW)

MIDWAY SANITATION DISTRICT

 CHAIRMAN

 DATE

MIDWAY IRRIGATION COMPANY

 CHAIRMAN

 DATE

WASATCH COUNTY SURVEYOR

APPROVED AS TO FORM _____

 SURVEYOR

 DATE

 ROS #

WASATCH COUNTY RECORDER

PROJECT
C20-020

SHEET
1

ISSUE DATE
 8/19/2021

Summit Engineering Group Inc.
 Structural • Civil • Surveying
 55 WEST CENTER • P.O. BOX 176
 HEBER CITY, UTAH 84032
 P: 435-854-9229 • F: 435-854-9231

Developer
 Sam Castor
 702-371-0724
 scastor@gmail.com

COPYRIGHT © 2021
 SUMMIT ENGINEERING GROUP, INC.

WARNING/ALERTATION
 IT IS A VIOLATION OF LAW FOR ANY PERSON UNLESS ACTING UNDER THE DIRECTION OF THE PROFESSIONAL LAND SURVEYOR TO ALTER ANY ITEM ON THIS DOCUMENT IN ANY MANNER. ANY LICENSEE WHO ALTERS THIS DOCUMENT IS REQUIRED BY LAW TO ATTEST THEIR SEAL AND THE NOTATION "ALTERED BY" FOLLOWED BY THEIR SIGNATURE AND SPECIFIC DESCRIPTION OF THE ALTERATIONS.

RISING RANCH SUBDIVISION PLAT

LOCATED IN THE NORTHWEST 1/4 OF SECTION 34, TOWNSHIP 3 SOUTH, RANGE 4 EAST, SLB&M,
 MIDWAY, WASATCH COUNTY, UTAH

CITY ENGINEER SEAL

CLERK-RECORDER SEAL